

**CLUE #21**

BLOCK NAME	MAKE	GRAYSCALE VERSION	MAIN FABRIC SELECTION	ALTERNATE FABRIC SELECTION
RESPECT	3			

OVERVIEW	SPECIAL INSTRUCTIONS	TOOLS
<ul style="list-style-type: none"> <li><input type="checkbox"/> <b>Respect</b> Block is made up of 2 sets of Diamond Triangles (3 each) and (3) 2-Patch Triangles.</li> <li><input type="checkbox"/> All the Diamond Triangles will be constructed the same. However, they will be trimmed differently depending on the unit and their placement in the block.</li> </ul>	<ul style="list-style-type: none"> <li><input type="checkbox"/> Select the FQ Remnants from the previous Block #10.</li> </ul>	Studio 180 Design Star 60™ <b>GENERAL INSTRUCTIONS</b> <ul style="list-style-type: none"> <li><input type="checkbox"/> HWOFF = Half Width of Fabric, cut from a Fat Quarter, typically 20-21".</li> <li><input type="checkbox"/> WOF = Width of Fabric, cut selvage to selvage, typically 40-42".</li> </ul>
<ul style="list-style-type: none"> <li><input type="checkbox"/> For tips on this week's block, read this week's <a href="#">Sew on the Go Blog post</a> or <a href="#">Online Class</a> (Clue &amp; Class members only).</li> <li><input type="checkbox"/> Basic instructions are provided below. If you need additional information, refer to the Star 60 instructions.</li> </ul>		

**CUTTING INSTRUCTIONS AND DIRECTIONS WILL PRODUCE: 3 BLOCKS**

	UNIT	# OF UNITS	PLACEMENT	FABRIC VALUE	CUT
A	<b>Multi-Colored Side Diamond Triangles</b> 	9	Diamond	Background	(1) 2 ¼" x WOF Strip
			Left Side Triangles	Med-Dark	(1) 2 ½" x HWOFF Strip
			Right Side Triangles	Light-Med	(1) 2 ½" x HWOFF Strip*
B	<b>2-Patch Triangle</b> 	9	Triangle	Light-Med	(1) 2 ½" x HWOFF Strip*
			Half Hexagon	Med-Dark	(2) 2 ¼" x HWOFF Strips
C	<b>Diamond Triangle LM/BG</b> 	9	Diamond	Light-Med	(2) 2 ¼" x HWOFF Strips *In place of 2 <sup>nd</sup> strip, trimmed down LM Remnant from above.
			Side Triangles	Background	(1) 2 ½" x WOF Strip

**SUB-CUTTING TRIANGLES**

- Gather** the (1) 2 ½" Med-Dark Strip for Unit A Side Triangles, (2) 2 ½" Light-Med Strips for Unit A Side Triangles and Unit B Triangle, and (1) 2 ½" Background Strip for Unit C Side Triangles. For the next step, let's start with the Light-Med Strips.
- Position** the remnant Light-Med Strips open on the cutting mat with the Star 60 tool on top of the fabric. **Align the mark near the tip of the tool** with the top of the strips and **the 2 ½" horizontal line on the tool with the bottom edge of the strip.**

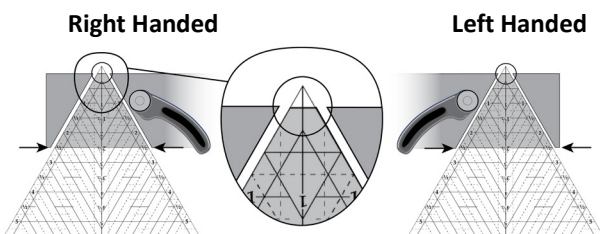

3. **To cut**, right handed quilters will cut from left to right. Left handed quilters will cut from right to left. Cut up one side of the tool and down the other.
4. **Rotate** the Star 60 tool 180° so that the sharp point is closest to you. **Align the 2 ½" horizontal line of the tool** with the **upper edge of your strip** while also aligning one edge of the tool with the previously trimmed edge. **Note:** the mark near the tip of the tool should **align with the bottom of the strip**. Cut the next triangle shape from this strip or another strip of similar value. Continue rotating, aligning, and cutting until you have the **(18) Triangles**. **Assign (9) to Unit A – Side Triangles and (9) to Unit B – Triangles.**



5. **Repeat** steps 7-10 with the following strips:
  - **Med-Dark (1) 2 ½" Strip(s)**, cutting **(9) Triangles** for Unit A –Side Triangles
  - **Background (1) 2 ½" Strip(s)**, cutting **(18) Triangles** for Unit C – Side Triangles.

### SUB-CUTTING DIAMONDS

6. **Gather (1) 2 ¼" Background Strip** for Unit A Diamonds and **(2) 2 ¼" Light-Med Strips\*** for the Unit C Diamonds. For the next step, let's start with the Background Strip. \*One may be the remnant from the Triangles.
7. **Position** the Background Strip open on the cutting mat and trim one short edge at a 60° angle as shown with the edge of the strip on the centerline. Right handed quilters will start at the left side of the strip while left handed quilters will start at the right side. Cut off as little as possible from your strip.

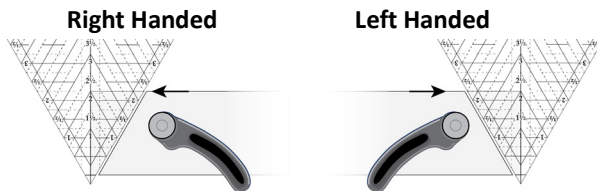

8. **Position and trim.** Align the Diamond Point guidelines with the raw edges of the strip and the just trimmed angled cut. Use the 4" Diamond Point guidelines and cut along the leading edge of the tool to create the diamond shapes.



9. **Continue** aligning and cutting until you have **(9) Diamonds**. **Assign (9) to Unit A – Diamonds**
10. **Repeat** steps 2-4 with the following strips:
  - **Light-Med (1) 2 ¼" Strip**, cutting **(9) Diamonds** for Unit C – Diamonds.

### SUB-CUTTING HALF HEXAGONS

11. **Gather (2) 2 ¼" Med-Dark Strips** for B Half Hexagons.
12. **Position** the Med-Dark Strips open on the cutting mat and position the Star 60 tool on the fabric. **Align** the bottom edge of the strip with **the 4" horizontal line** and the top edge of the strip should align with the **1 ¾" horizontal line** of the tool.

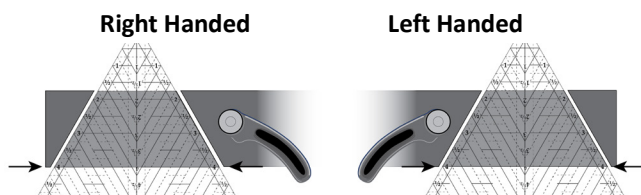

13. **Cut on both sides** of the tool to create the half hexagon. Right handed quilters will cut from left to right. Left handed quilters will cut from right to left.
14. **Rotate** the Star 60 tool 180° and **align** the 4" horizontal line of the tool with the upper edge of your strip while also aligning one edge of the tool with the previously trimmed edge. Continue rotating and cutting until you have the **(9) Half Hexagons**.

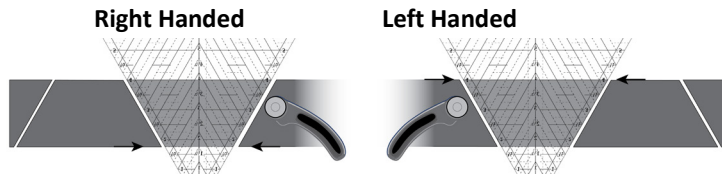

### CONSTRUCTING UNITS – UNIT A & C DIAMOND TRIANGLES

15. **Pair and lay out** the Diamonds with the proper Side Triangles:
  - **Unit A:** (9) Background with (9) Med-Dark Triangles and (9) Light-Med Side Triangles
  - **Unit C:** (9) Light-Med Diamonds with (18) Background Side Triangles
16. **Position and stitch** the Diamond to the Left Side Triangle. Take the Diamond and flip it left onto the Left Side Triangle. Match the edge of the diamond with the blunt corner of the triangle and align the raw edges. **Stitch** with the Diamond on top with your best ¼" seam allowance. **Press** the seam open and **trim** the dog ears to match the Diamond's edge. Repeat for all units.
17. **Position and stitch** the remaining Side Triangles on the other side of the Diamond point. **Align** the flat corner of the Side Triangle with the edge of the Diamond. Align the raw edges. With the Diamond on top, **stitch** with your best ¼" seam allowance. **Press** the seam open. Repeat for all the units.

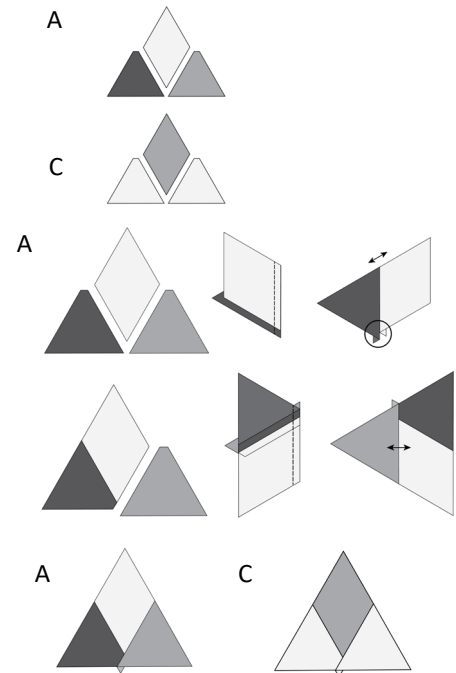

**Note:** The Diamond Triangle Units will be trimmed depending on their placement and construction in the Block; label and set aside until we get organized.

### CONSTRUCTING UNITS - UNIT B- 2-PATCH TRIANGLES

18. **Gather and lay out** (9) Light-Med Triangles with the (9) Med-Dark Half Hexagons.
19. **Position and stitch** the Half Hexagons to the Triangles. Center the Half Hexagon's shorter side with the Triangle's wider side, placing right sides together. Take time to ensure the blunt side of the Triangle is not sewn to the Half Hexagon. Use your best ¼" seam allowance. **Press** the seam open. Repeat for all the units.

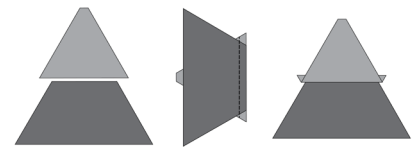

**Note:** The 2-Patch Triangle Units will be trimmed depending on their placement and construction in the Block. First we must get organized.

**TIME TO GET ORGANIZED & TRIM**

20. **Organize** the units according to the **chart below**. Once you verify that you have the proper number of each unit, you will want to divide the units according to the chart, identifying which side of the unit will be trimmed using the instructions below. Use your placement cards and the [Wonder Clips](#) to label the units. Check out the [Blog](#) for an example of this technique.

	UNIT	TOTAL	TRIM BOTTOM	TRIM TOP (L&R) POINT	TRIM LEFT
A		9	9		
B		9			9
C		9		9	

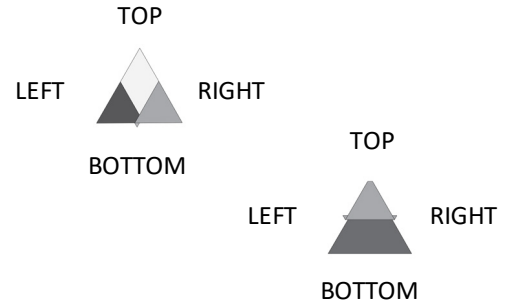

**TRIMMING THE BOTTOM – UNIT A**

21. **For all (9) A Units:** position the Diamond Triangle Unit on the cutting mat with the bottom facing the right for those that are right handed or the left if you are left handed. Locate and **align** the Flat Edge trim lines on the tool with the seams of the diamond and **trim**. You should be trimming about an  $\frac{1}{8}$  -  $\frac{1}{4}$ ".

**Right Handed**

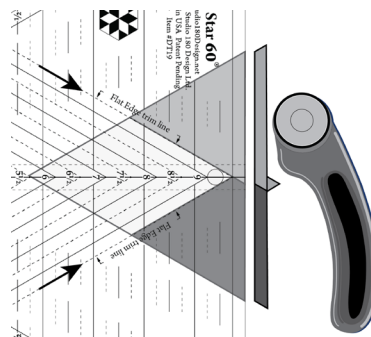

**Left Handed**

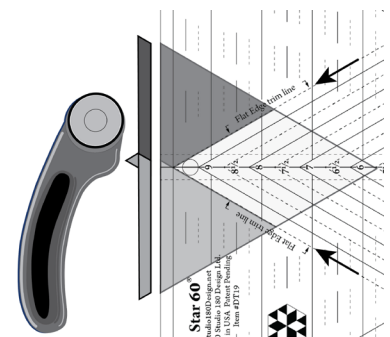

22. **Label with unit and trimmed side.**

**TRIMMING THE LEFT SIDE – UNIT B**

23. **For all (9) B Units:** position the 2-Patch Triangle Unit on the cutting mat so for those that are right handed the blunt top is in the 2 o'clock position or 12 o'clock if you are left handed. **Center** the unit and **align the seam line of the Triangle and Half Hexagon to the 1 3/4" guideline**. The bottom of the unit should line up with the 3 3/4" guideline. **Trim** the left side of the triangle. You should be trimming about an  $\frac{1}{8}$  -  $\frac{1}{4}$ ".

**Right Handed**

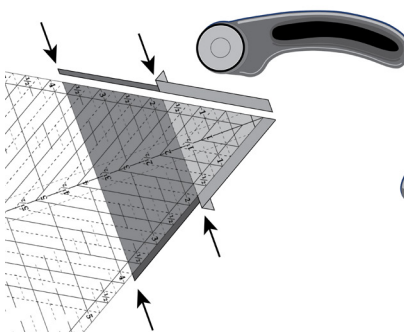

**Left Handed**

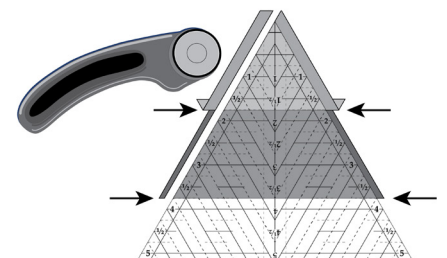

24. **Label with unit and trimmed side.**

**TRIMMING THE TOP POINT (LEFT & RIGHT) – UNIT C**

25. **For all (9) C Units:** position the Diamond Triangle Unit on the cutting mat so that for those that are right handed the top is in the 2 o'clock position or 10 o'clock position if you are left handed. **Align the 3" finished size Diamond Point guidelines** with the sewn seams. **Trim** along both sides of the tool. You should be trimming about an  $\frac{1}{8}$  -  $\frac{1}{4}$ " on both sides. Repeat for all units.

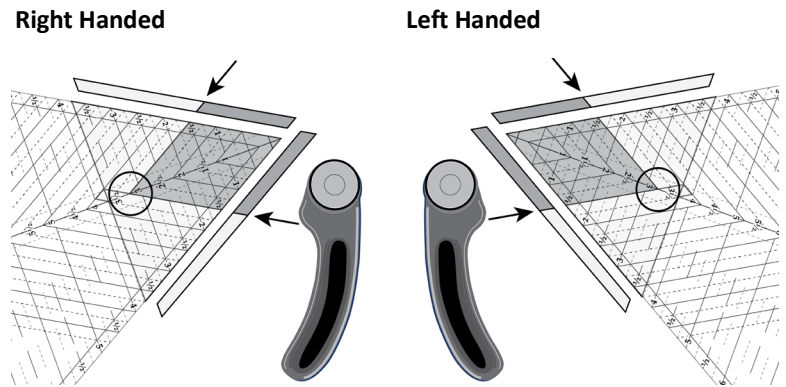

26. **Label with unit and trimmed sides.**

**CONSTRUCTING BLOCKS**

**These Blocks must be constructed in a particular order.** It is especially important to follow the steps in the **exact order**. Double check the **orientation** of the unit and ensure you have chosen the unit labeled with the proper cut side. **Tip:** When going through the construction steps, you will always be sewing trimmed sides together. If you find yourself stitching a non-trimmed side, stop and double check that you have the proper unit and that you have it oriented properly.

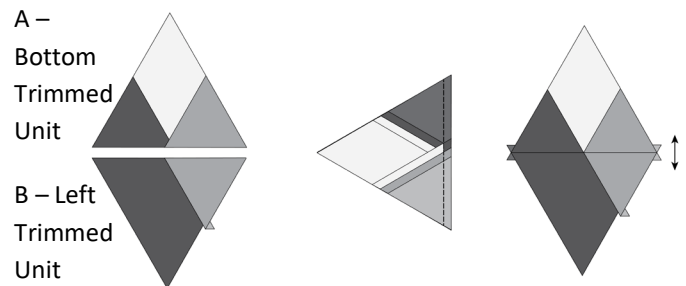

- 27. **Gather and position** the (9) A Units (Bottom trimmed) and (9) B Units (Left trimmed). Be careful with this orientation. The A Units should have their trimmed bottom side toward the trimmed left side of the B Units.
- 28. **Position and stitch.** Flip the A Unit onto the B Unit, **lining up the trimmed edges**. They should be the same shape. **Stitch** with your best  $\frac{1}{4}$ " seam allowance. Repeat for all (9) units and **press** the seam open.
- 29. **Trim** the B Unit. Position the unit on the cutting mat so that for the right handed the B Unit is in the 2 o'clock position or 10 o'clock if you are left handed. **Align the 3" Diamond Point guideline with the seam line between the Triangle and Half Hexagon of the B Unit while the Diamond of the A Unit is centered on the centerline.** **Additionally, the seam between the A and B Units should align with the 3  $\frac{1}{4}$ " guideline.** Trim both sides of the exposed B Unit Triangle.

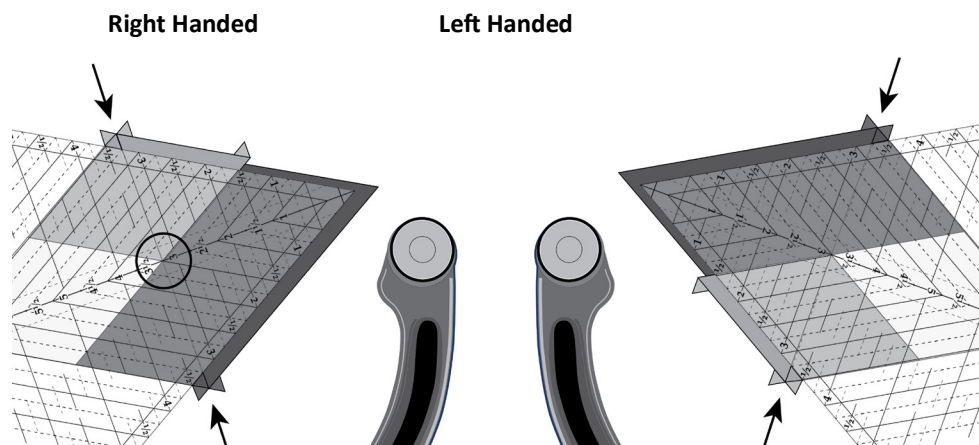

30. **Gather** (6) of the C Units (L&R Point trimmed) and layout as shown with (3) of the diamond shaped units from step 29 to make a larger Triangle. Make sure the Unit C - Point trimmed units' trimmed sides are positioned toward the diamond

shaped units (arrows below identify the sides that are trimmed). The untrimmed side of Unit C should be on the outside of the unit.

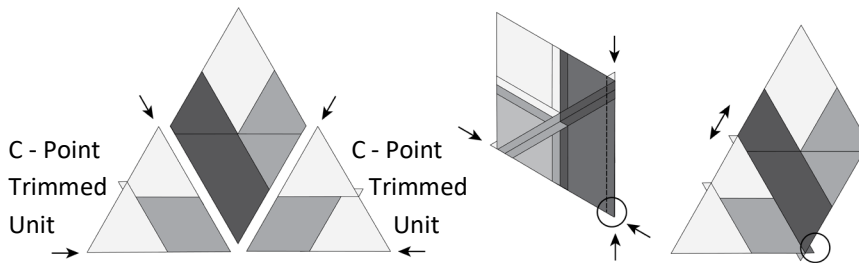

31. **Position and stitch** the three units as shown. Start by stitching the diamond shaped unit with the C Unit (L&R Point trimmed) which is on the left. Be careful and **match the raw edges of the trimmed triangle points**. **Stitch** with your best  $\frac{1}{4}$ " seam allowance. Repeat for all units, **press** the seams open and **trim** the dog ear of just the Unit B Med-Dark.
32. **Position and stitch** the remaining C Unit (Point trimmed) onto the just sewn unit. Be careful to **align the raw edges of the trimmed triangles**. **Note: Unit C's bottom point should align with the dog ear** of the just sewn unit. When you do this, **Unit C's top point will lay atop the other dog ear** of the unit. **Stitch** with your best  $\frac{1}{4}$ " seam allowance. Repeat for all units, **press** the seams open and **trim** the dog ear. This is the Top Unit. Set aside for now.

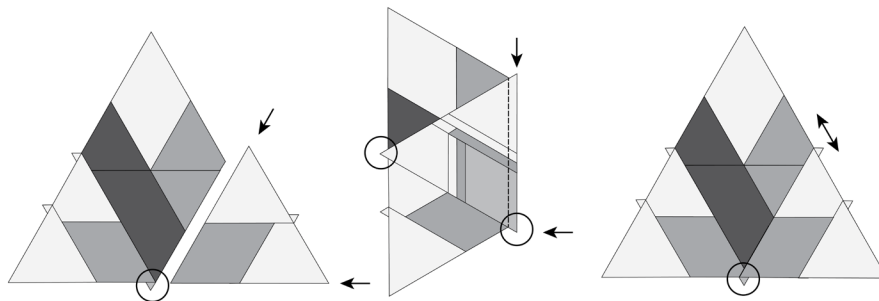

33. **Gather and position** the last (3) C Units (L& R Point trimmed) with the remaining (6) diamond shaped units created in step 29.

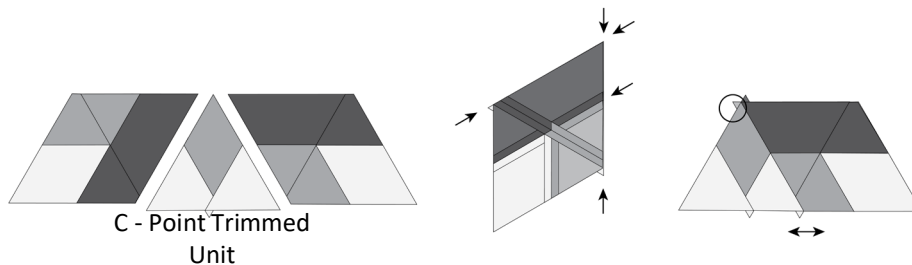

34. **Stitch 3 units together** as shown. Start by stitching the right diamond shaped unit with the individual C Unit (L&R Point Trimmed). Carefully **match the diamond point seam with the seam intersection and the raw edges of the trimmed triangle points**. **Stitch** with your best  $\frac{1}{4}$ " seam allowance. Repeat for all units. **Press** the seams open and **trim** the dog ear of Unit C Light-Med.
35. **Position and stitch** the just sewn unit onto the remaining diamond shaped unit. Be careful to **match the Diamond point seam with the seam intersection and align the raw edges of the trimmed triangles**. **Unit B's dog ear will lay on top of the Unit A's trimmed bottom**. **Stitch** with your best  $\frac{1}{4}$ " seam allowance. Repeat for all units. **Press** the seams open and **trim** the dog ear. These are the Bottom Units.

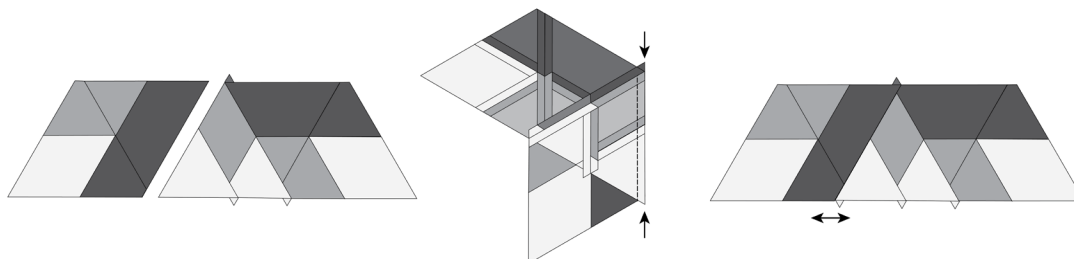

36. **Gather** the Top Units from step 32 and the Bottom Units that were just sewn.

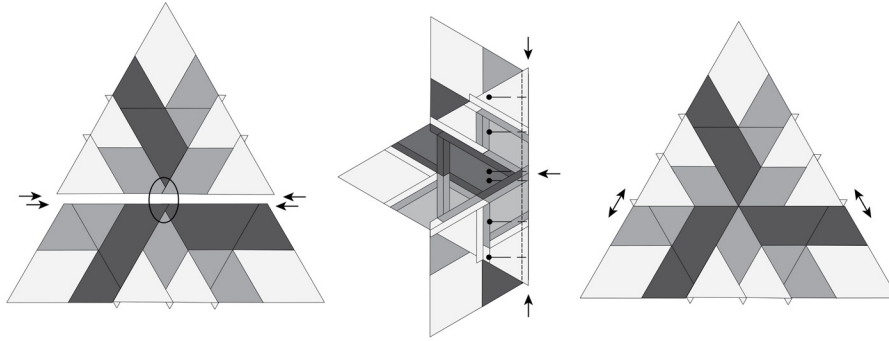

37. **Position and stitch.** Be careful to **align all diamond point seam intersections as well as the raw edges of the trimmed triangles.** **Stitch** with your best  $\frac{1}{4}$ " seam allowance. Repeat for all units. **Press** the seams open.

38. **Trim the blocks.** Position the block on the cutting mat so that the top point is away from you and the bottom side near you. It helps to turn it slightly to 2 o'clock position if you are right handed and to 10 o'clock position if you are left handed. **Align the 3", 6", and 9" Diamond Point guidelines with the seams of the A Unit at the top of the block as well as the B Unit and C Unit.** The  $3\frac{1}{2}$ " and  $6\frac{1}{2}$ " horizontal guidelines will align with seams as well. **Trim** on both sides of the Block.

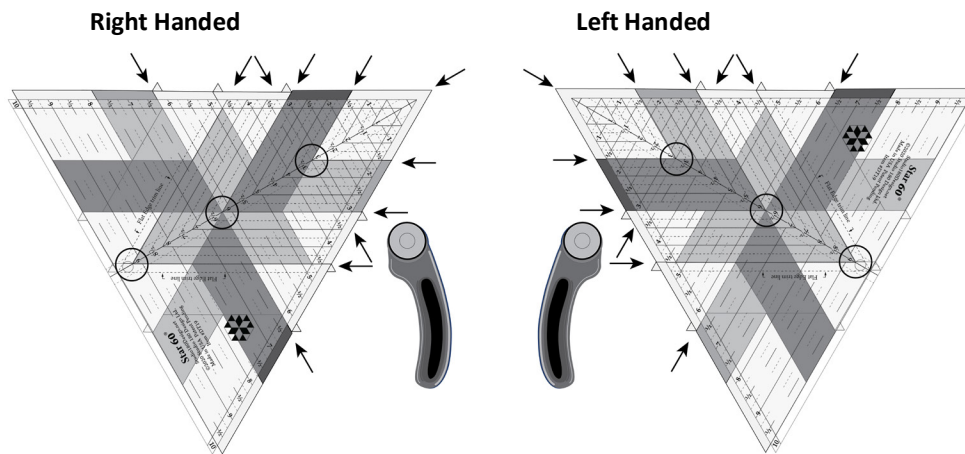

39. **Rotate** the block counter-clockwise for right handed, or clockwise for left handed exposing the untrimmed edge. For those that are right handed, line up the previously trimmed **edges of the block, one with the left edge of the Star 60 tool and the other with the 9 1/2" guideline.** For those that are left handed, line up the previously trimmed **edges of the block, one with the right edge of the Star 60 tool and the other with the 9 1/2" guideline.** Note: All the same seam intersections, stated in step 38, will line up as well. **Trim** the remaining side.

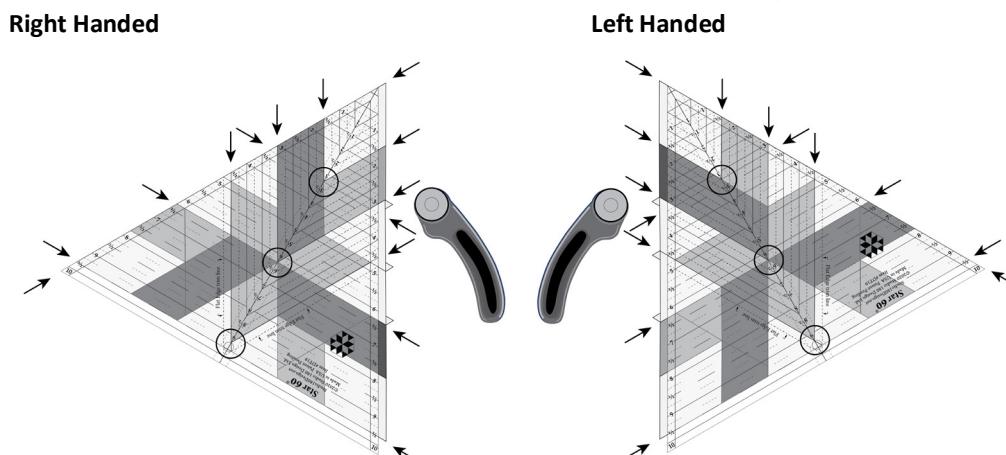

40. **Tada! You made it.** Be sure to post your photos in the [Best of the 60's Facebook Group](#).

## ADDITIONAL WORK

41. Label and go to the “Group 9” Construction Instructions. Those instructions are available as a download in your Clue repository (Clue only members) or in your curriculum (Clue and Class members), filed below this Clue.

**Please follow the important instructions.** In order to make the best use of your fabric, you need to follow these instructions.

## IMPORTANT INSTRUCTIONS

- Place the Background Remnant Strips in your storage bag marked “Background scraps”. You can use these strips for any block going forward that may require a strip of that same height. Do not cut them down to a different height.
- For each of the remaining fat quarters used in this clue and fat quarter remnant strips, keep these, and place them in your storage bag marked “Fat Quarter scraps”.

## CLUE #21 RECAP

- **Song Trivia – *Respect***, 1967, Aretha Franklin. *Respect* was released by Otis Redding in 1965. Though no one knows for sure who wrote the original version of the song, some say it was the guitarist at the recording studio; however, Otis has been credited. Redding’s version, released in the summer of 1965, only made it to the 35<sup>th</sup> position on the Billboard Charts, while, in 1967, the song became a hit and signature song for singer Aretha Franklin. The music in the two versions is significantly different, it has more than a few changes in the lyrics. In fact, the stories told by the songs have a different flavor. Redding's version is a plea from a desperate man, who will give his woman anything she wants. He will not care if she does him wrong if he gets his due respect when he brings money home. However, Franklin's version is a declaration from a strong, confident woman, who knows that she has everything her man wants. She never does him wrong and demands his "respect". Franklin's version adds the "R-E-S-P-E-C-T" chorus and the backup singers' refrain of "Sock it to me, sock it to me, sock it to me...".
- **Personal Note:** I love the Aretha Franklin version. I had the pleasure of meeting Aretha Franklin in the early 1990s, when she was showcased at the Trump Taj Mahal. Aretha would perform every summer at the Taj, and my sister and I went to at least one of her performances each year when I worked at the Taj. Great memories.
- [Link to Video](#)

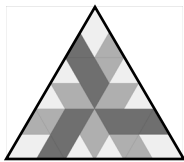
CLUE	BLOCK NAME	GRAYSCALE VERSION	UNIT CUT HEIGHT SIZE	UNIT FINISH HEIGHT SIZE	# OF BLOCKS
#21	RESPECT		9 ½”	9”	3