

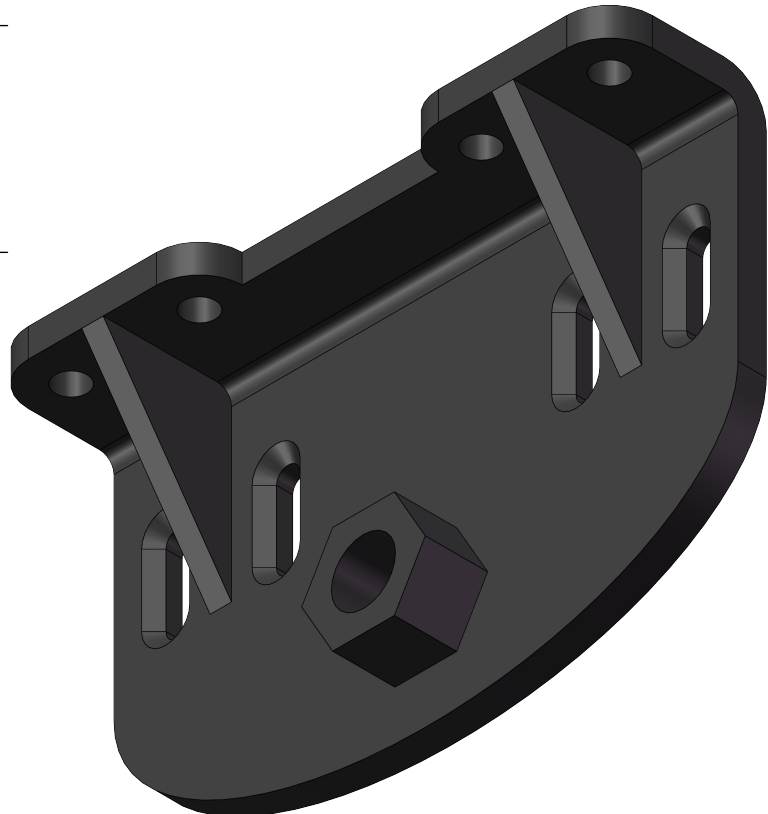

Model File Name: ATP-1030

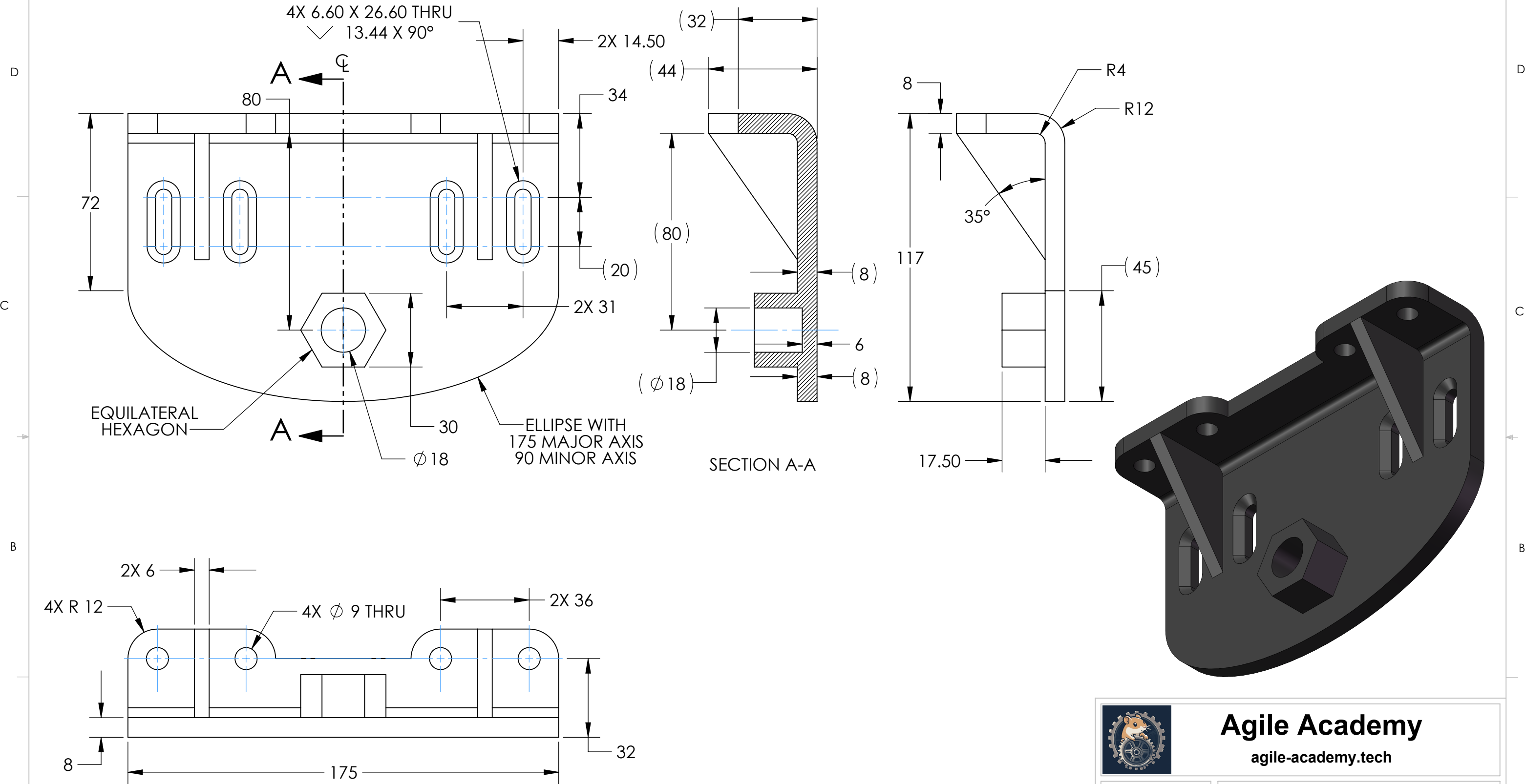
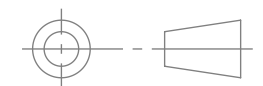

DIMENSIONS IN MM
PART IS SYMMETRIC ABOUT ϕ

THIRD ANGLE PROJECTION



 <p>Agile Academy agile-academy.tech</p>	
<p>DO NOT SCALE PRINT</p> <p>TOLERANCES UNLESS OTHERWISE SPECIFIED</p> <p>.XX ± .05 .XXX ± .020 ANGLE ± 1°</p> <p>SIZE B</p>	
<p>MOUNT 02 SAMPLE PARTS</p>	
<p>DRAWN BY JEV</p> <p>CHECKED BY JLM</p>	<p>DRAWING NO. ATP-1030</p> <p>SCALE: 2:3 DATE 2/9/2025 SHEET 1 OF 1</p>

- NOTES:
1. DRAWING TO BE INTERPRETED IN ACCORDANCE WITH ASME Y14.5-2018
 2. MATERIAL: MALLEABLE CAST IRON
 3. DENSITY: 7,300 kg/m³
 4. VOLUME: 200408.55 CUBIC MILLIMETERS
 5. MASS: 1462.98 GRAMS