

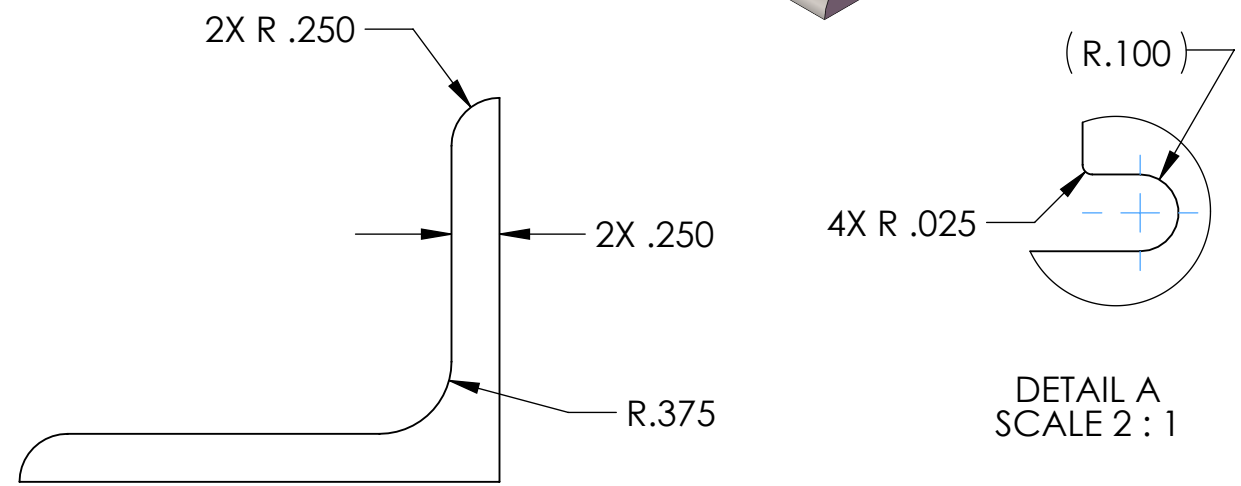

Model File Name: ATP-006

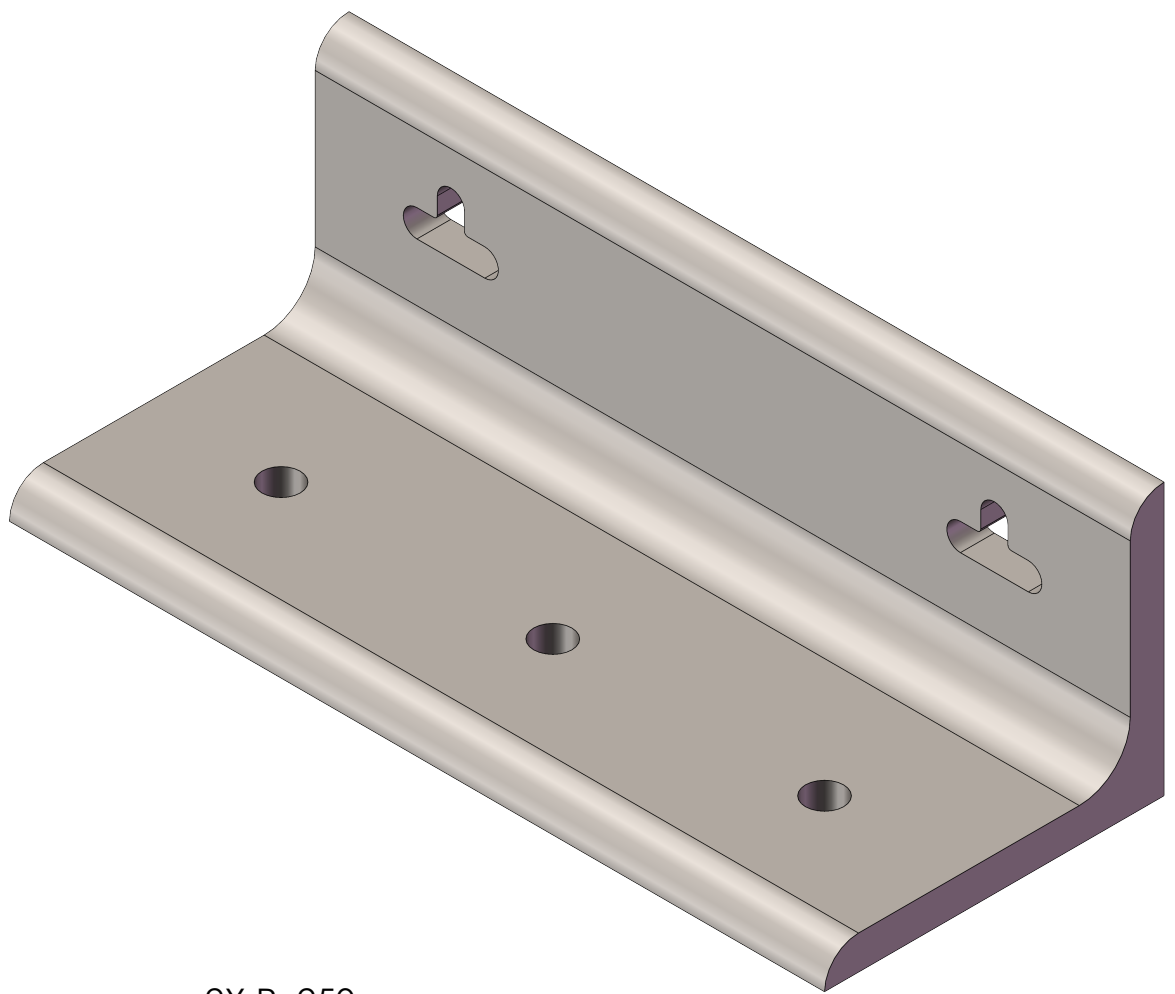
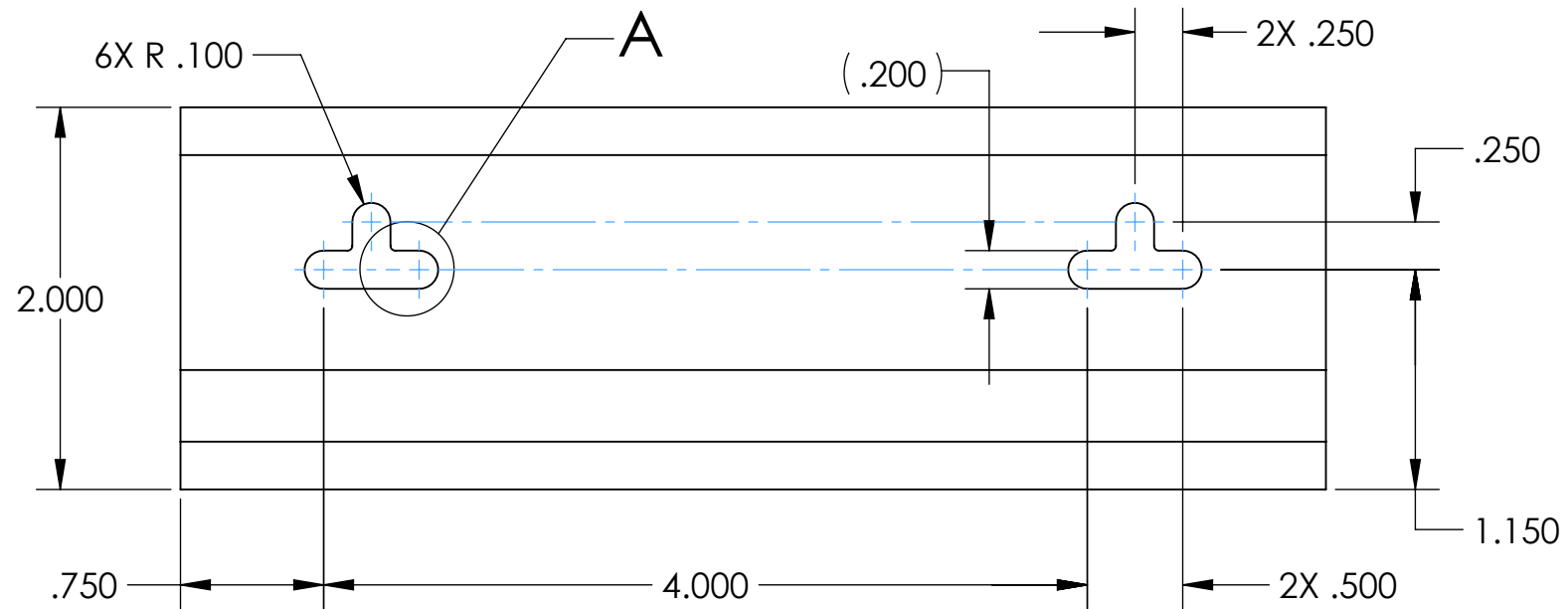
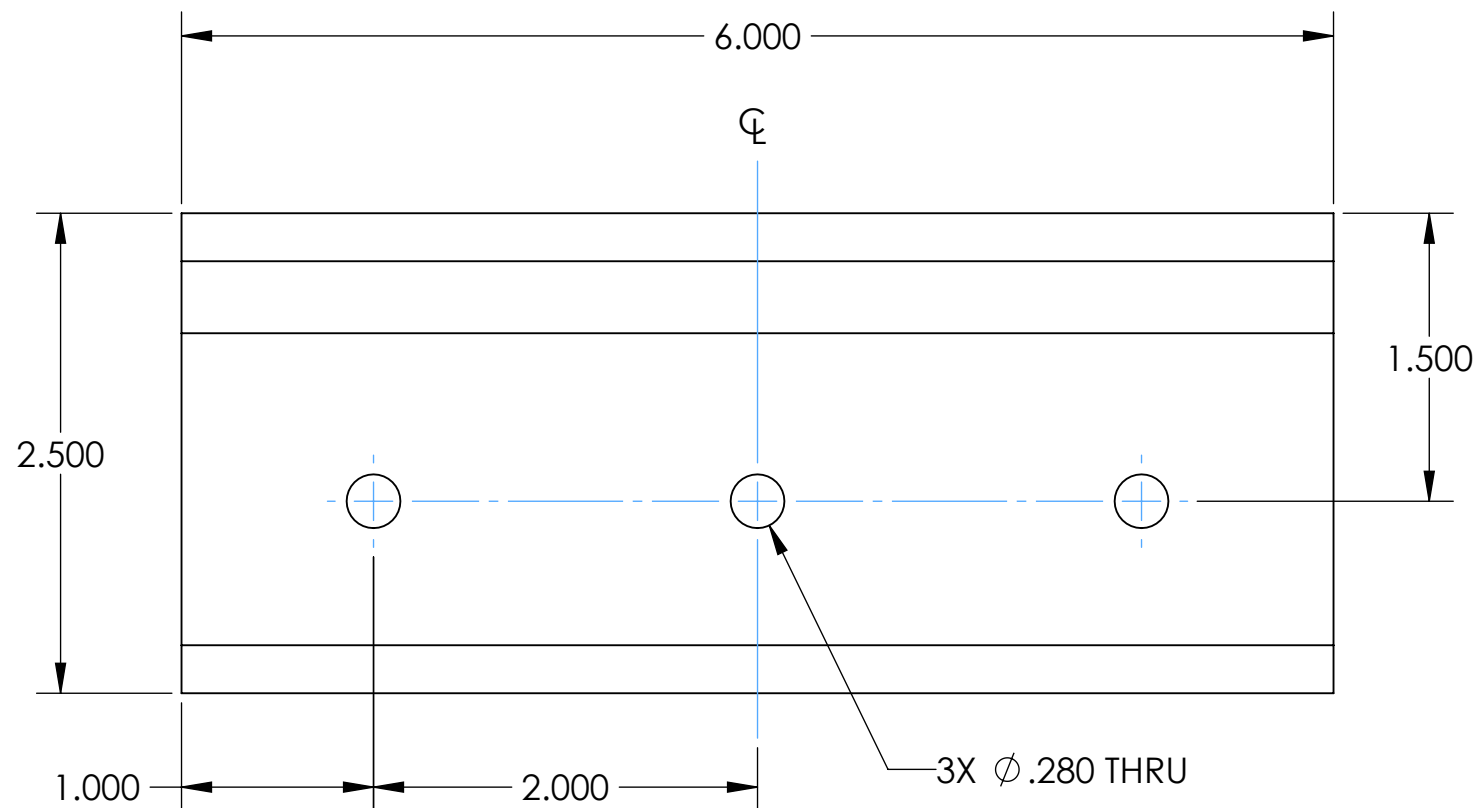
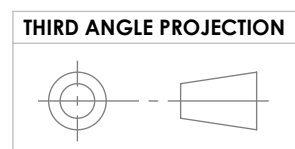

- NOTES:
 1. DRAWING TO BE INTERPRETED IN ACCORDANCE WITH ASME Y14.5-2018
 2. MATERIAL: ASTM A36 STEEL
 3. DENSITY: 7,850 kg/m3
 4. VOLUME: 6.260 CUBIC INCHES
 5. MASS: 1.775 LBS

DIMENSIONS IN INCHES
 PART IS SYMMETRIC ABOUT \varnothing



 Agile Academy agile-academy.tech	
DO NOT SCALE PRINT TOLERANCES UNLESS OTHERWISE SPECIFIED .XX ± .01 .XXX ± .005 ANGLE ± 1°	
SIZE B	
DRAWN BY JEV	DRAWING NO. ATP-006
CHECKED BY JLM	SCALE: 3:4 DATE 1/5/2025 SHEET 1 OF 1