

Crime Scene Sketch

The crime scene sketch is an invaluable aid in recording investigative data. It is a permanent record that provides supplemental information that is not easily accomplished with the exclusive use of crime scene photographs and notes. A crime scene sketch depicts the overall layout of a location and the relationship of evidentiary items to the surroundings. It can show the path a suspect or victim took and the distances involved. It can be used when questioning suspects and witnesses. During trial, the crime scene diagram correlates the testimony of witnesses and serves as a tool for relaying reference and orientation points to the prosecutor, judge and jury.

I. Sketching the Crime Scene

Before beginning a sketch, obtain a comprehensive view of the scene. Determine the sketch limits – decide what to include and what to exclude. If the scene is complicated, a number of sketches may be necessary for adequate documentation.

Types of Sketches

- Overview sketch – consists of a bird’s-eye-view or floor plan sketch of the scene. This is the most common type of sketch and consists of items on the horizontal plane (see Figure 4-1).
- Elevation sketch – portrays a vertical plane rather than a horizontal plane. Examples include bloodstain patterns on vertical surfaces such as walls or cabinetry and bullet holes through windows (see Figure 4-2).
- Exploded view or cross-projection sketch – consists of a combination of the first two sketches. It is similar to a floor plan except the walls have been laid out flat and objects on them have been shown in their relative positions (see Figure 4-3).
- Perspective sketch – depicts the scene or item of interest in three

Crime Scene Sketch 4

dimensions. It is the most difficult sketch to create and requires some artistic skill (see Figures 4-4 and 4-5).

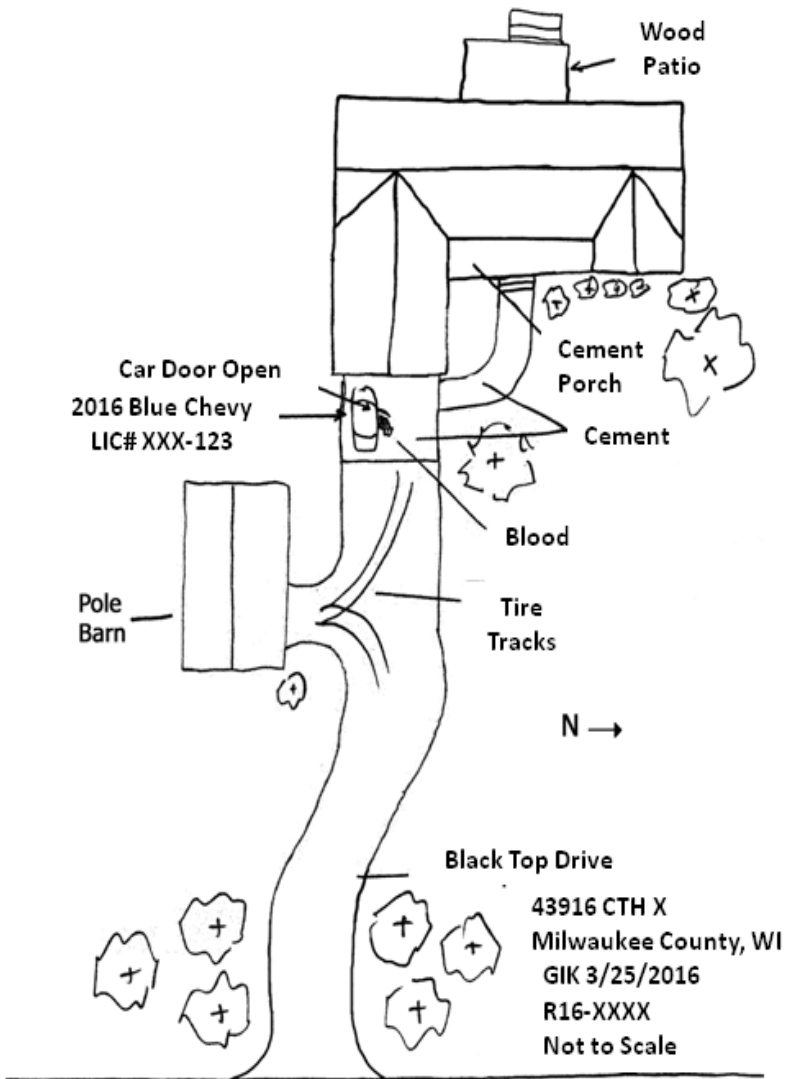

Fig. 4-1 Overview sketch of an exterior crime scene.

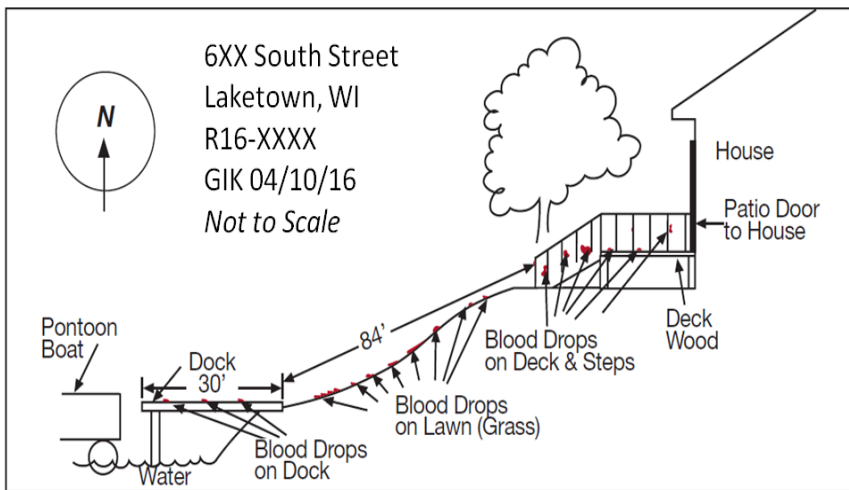

Fig. 4-2 Elevation sketch illustrating a blood trail.

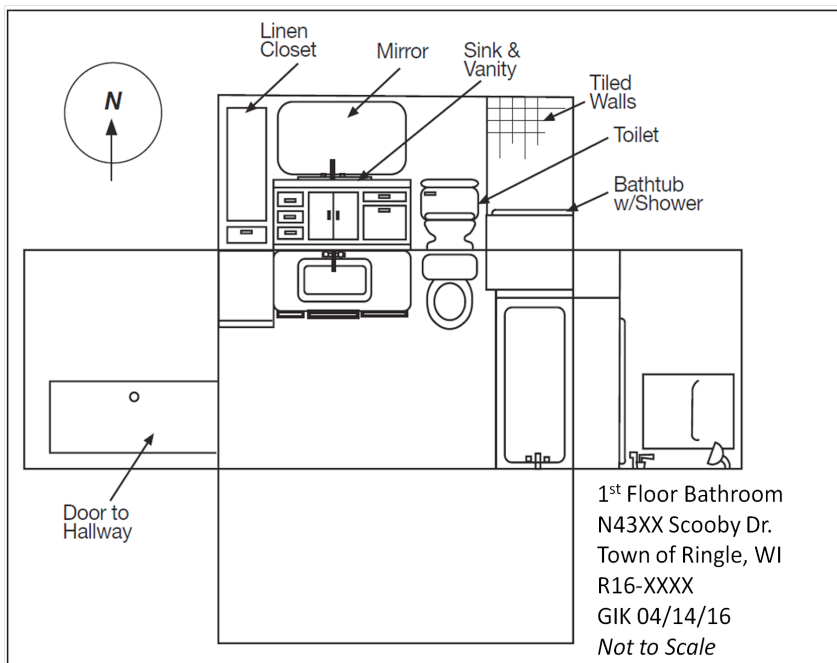

Fig. 4-3 Exploded view sketch of a bathroom.

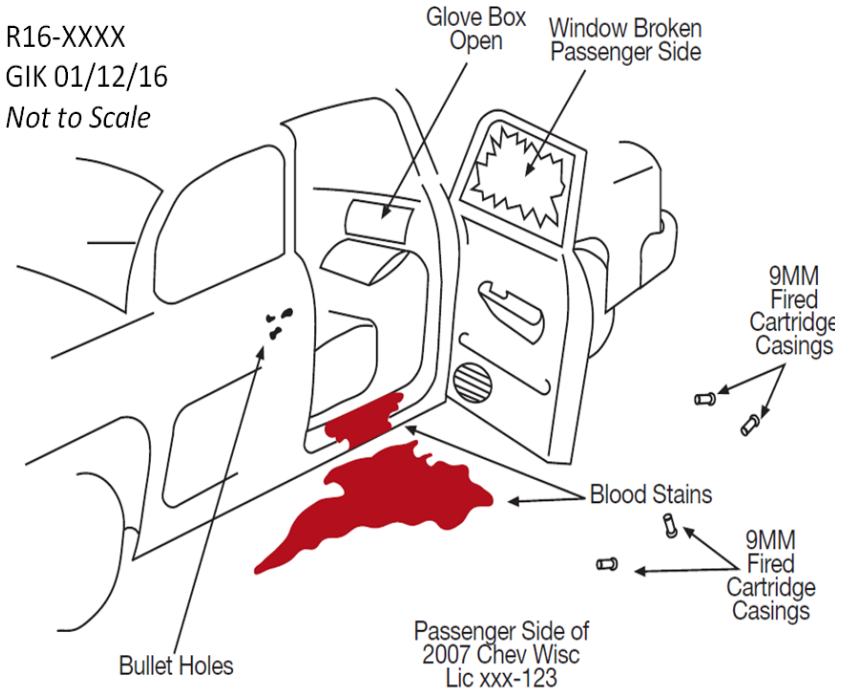

Fig. 4-4 Perspective sketch of the passenger side of a vehicle.

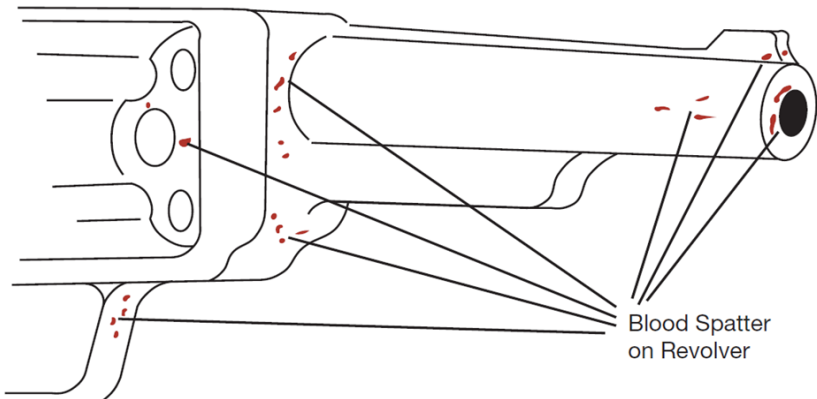

Fig 4-5 Perspective sketch illustrating suspected blood spatter on a

revolver.

To Scale or Not to Scale

- **“Drawn to Scale” diagrams**
 - o To avoid a distorted view of the scene, measurements must be reduced in proportion so that they bear correct relationship to each other.
 - o Select the scale of the diagram by fitting the longest dimension in the scene to the area of the paper being used.
 - o Graph paper should be used when creating this type of sketch. Each block represents a specified length of measurement. Use convenient units for the scale (one block = 1 foot).

- **“Not to Scale” diagrams**
 - o Sketch can be accomplished more quickly than a scaled diagram.
 - o Items are placed in the diagram based on approximation. This type of diagram may provide a distorted view of the scene. Correct proportions and relationships between objects may not be maintained.
 - o Measurements are recorded on the sketch or in a chart.
 - o This rough sketch may be used to complete a scaled diagram later.
 - o These diagrams should be clearly marked Not to Scale.

Equipment

- Supply of writing implements – pencils may be used for the overall sketch. A sketcher may choose to use red pencils to denote bloodstains, and highlighters or other colored pencils to mark different types of evidence on the sketch. Preserve a pencil created sketch in a permanent manner as soon as possible. A good method for preservation is to photocopy the finished sketch and include the photocopy with the original.

Crime Scene Sketch 4

- Blank paper – graph paper, while not essential, simplifies scale drawing.
- Drawing surface such as a clipboard.
- Measuring devices – tape measures are the most common tool used and should be at least 50 to 100 feet long. Other measuring devices may include a surveyor's wheel, a laser rangefinder, or a Total Station. GPS coordinates may be useful in locating an outdoor scene.
- Ruler for drawing straight lines, drawing to scale, and making very short measurements.
- Magnetic compass to determining true north.

Creating the Sketch

- If the scene is large, make a very rough sketch of the area while obtaining an over-all view of the scene. This initial rough sketch serves as a reference when making more complete sketches. Enlarged sections of this rough sketch can be made as separate drawings in order to bring out greater detail.
- Begin taking measurements and laying out a rough sketch.
 - o Lay down a baseline. This usually consists of the longest uninterrupted side of a room or, if outdoors, the curb line, building line, or even an imaginary line between two fixed points.
 - o Take other measurements of the periphery of the scene and add them to the baseline.
 - o Having established the outer boundaries of the sketch, add various objects in their proper positions.
- Measurements – write them down!
 - o Measurements can be recorded directly on the sketch or in a chart.
 - o Long distances may be measured with the odometer on an automobile.
 - o Critical measurements should be checked by two people.

Locating Objects on a Sketch

All points require two measurements for a two-dimensional sketch. Three measurements are required for a perspective (3-D) sketch.

- Rectangular coordinates – an object (item 1, see Figure 4-6) is located by making a measurement at right angles from each of two walls. Works well for indoor measurements.

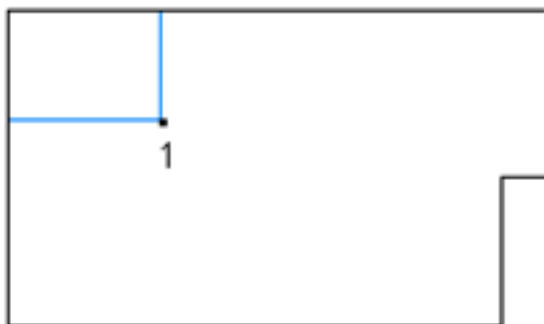

Fig. 4-6 Item 1 is located using rectangular coordinates.

- Transecting baseline - particularly useful in large, irregularly shaped outdoor areas.
 - o Transect the crime scene by laying down a tape measure along some convenient line so it crosses the entire area (blue line, see Figure 4-7).
 - o Locate this line in the diagram from fixed points at the scene.
 - o Locate objects in the crime scene by measuring their distance from this established baseline. Measurements must be taken at right angles to the tape.
 - o Record how far along the baseline the distance out to the

object was measured. This provides the two measurements needed to locate the object.

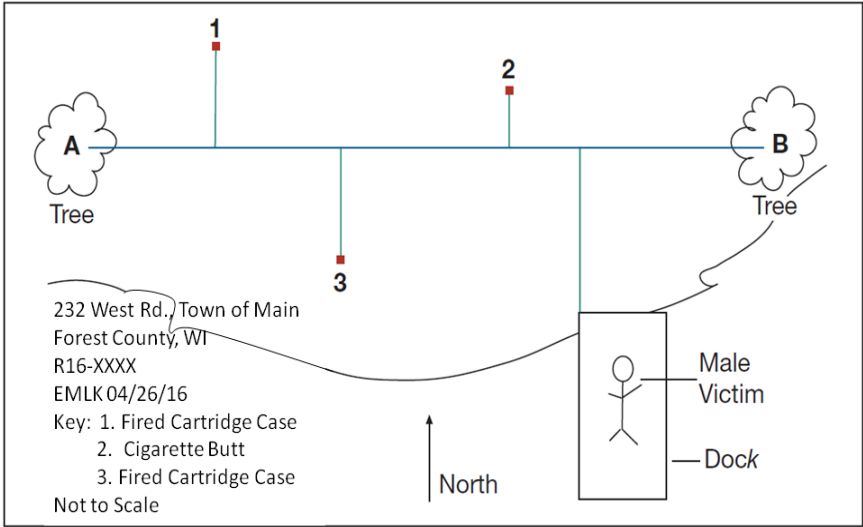

Fig. 4-7 Transecting Baseline. The blue transecting baseline AB is between two trees (trees can be marked with orange paint for later identification). The two measurements needed for each point are (1) how far each item is from the baseline (green lines north and south) and (2) how far east on the blue baseline from point A the objects are (distance to where the green lines intersect the blue). (This is for illustration. Additional measurements would be collected for the body and the dock.)

- Triangulation – measurements are taken from two fixed points at the scene to the object you desire to locate. For example, item 1 in Figure 4-8 is located by taking measurements (length of the green lines) from two corners of the building.

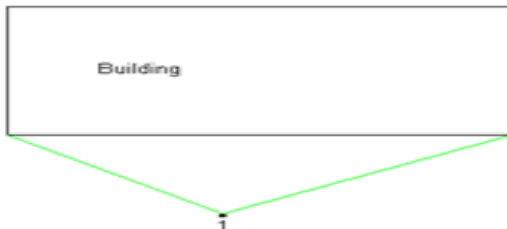

Fig. 4-8 Triangulation. Item 1 is located using triangulation from the two corners of the building.

Illustrating the Sketch

- Do not attempt to draw an object as it appears. Use symbols instead.
- Use lettered or numbered squares, circles, figures, or points to represent various objects in the sketch. Explain in the diagram key what these objects represent.
- If photography markers are used, ensure they correspond to same objects in the sketch. For example, if photo marker #5 is used to mark a handgun, make sure the handgun in the sketch is labeled #5.
- Label all doors and windows. Show with a curved line which way the door swings.
- Use an arrow to show the direction of the stairway.
- Use jagged lines to cut off unnecessary height or length.

Labeling the Sketch

The following should be recorded on the sketch:

- Address or location of scene.
- Case number.
- Date sketch was made and by whom.
- A key to identify the different objects in the sketch.
- An arrow to show the direction of north.
- Scale used for the sketch or the statement “Not to Scale”.

II. Computer Based Programs

Several CAD based programs are commercially available and can be used to create professional and accurate crime scene diagrams.

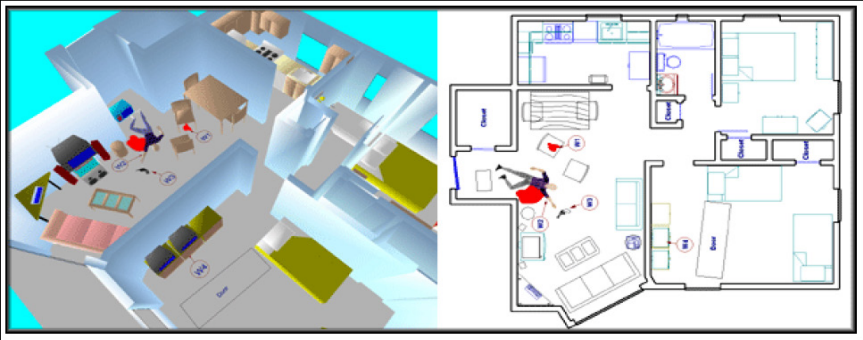

Fig. 4-9 Diagrams created using The Crime Zone™ software* and used with permission of The CAD Zone, Inc.

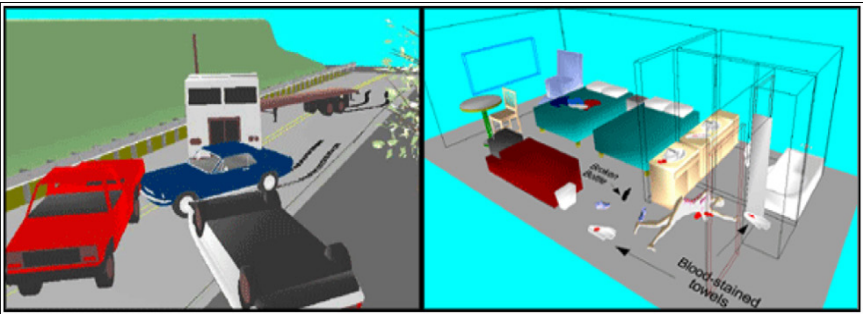

Fig. 4-10 Diagrams created using The Crime Zone™ software* and used with permission of The CAD Zone, Inc.

These types of programs can be used at the scene to record measurements and generate sketches or used at the office using rough sketch(es) created at the scene to generate sketches.

III. Latest Technology

Portable devices now exist that can perform a 360° scan of a crime scene in as little as 20 minutes, capturing millions of measurements of all objects visible to the scanner. Dozens of high-resolution images are captured automatically. The device requires only the space needed by a standard photographer's

tripod. The data generated can be used to find the distance between any two points in the scene, to view the scene from any vantage point (including directly overhead), and to create a full-color, 3D model for investigative and courtroom purposes.

The National Institute of Justice's Forensic Technology Center of Excellence (FTCoE) at RTI International directed an effort with criminal justice system communities, law enforcement, industry, and forensic input to conduct a landscape study of 3D laser scanning instruments. The study was summarized, is soon to be posted by FTCoE, and was located at commercial websites in abridged and complete forms at the time of this publication (see Leica's abridged version and Riegl USA's complete version*).

***Note:** The Laboratory does not endorse any one software program or device over another, nor does it endorse any one vendor over another.

Notes