

Kinetic Energy and Rotational Kinetic Energy

- Which of the following objects has kinetic energy? (Select all that apply)
 - A ball falling down
 - A book held at some height above the ground
 - A cylinder rolling down an incline
 - A ball rolling on the ground
- What is the SI unit for kinetic energy?
 - m
 - kg
 - J
 - m/s
- Kinetic energy...
 - is a vector quantity
 - is a scalar quantity
 - can be either a vector quantity or a scalar quantity
 - is not a vector quantity or a scalar quantity
- True or false: kinetic energy is a type of mechanical energy.
 - True
 - False
- A ball is kicked into the air. The kinetic energy of the ball at any time depends on which of the following? (Select all that apply)
 - The mass of the ball
 - The direction of the ball's velocity
 - The acceleration due to gravity, g
 - The speed of the ball
- Two objects are dropped from rest from a height of 10 m. Object A has a greater mass than object B. 1 second after being dropped, which object has a greater kinetic energy?
 - Object A
 - Object B
 - They have the same kinetic energy
 - Cannot be determined

7. A cannon ball of mass m is shot out of a cannon from the ground at an angle. A few seconds later the kinetic energy of the ball is K . At that moment, which of the following is equal to the speed of the ball?
- A mK
 - B $\sqrt{\frac{m}{2K}}$
 - C $\frac{2K}{m}$
 - D $\sqrt{\frac{2K}{m}}$
8. Object A and object B has the same kinetic energy, but object B has twice the speed of object A. What is the mass of object B in terms of the mass of object A, m_A ?
- A $m_A/2$
 - B $m_A/4$
 - C $2m_A$
 - D $4m_A$
9. Which of the following objects has rotational kinetic energy? (Select all that apply)
- A A moving block attached to a spring
 - B A block sliding down an incline
 - C A ball rolling on the ground
 - D A cylinder rolling down an incline
10. What is the SI unit for rotational kinetic energy?
- A m/s
 - B rad/s
 - C $\text{kg}\cdot\text{m}^2$
 - D J
11. A solid sphere and a hollow sphere with the same mass and radius are rotating with the same angular speed. Which object has the greater rotational kinetic energy?
- A The solid sphere
 - B The hollow sphere
 - C They have the same rotational kinetic energy
 - D Cannot be determined
12. Object A and object B have the same rotational inertia. Object B has an angular velocity of ω_B and object A has an angular velocity of $3\omega_B$. What is the rotational kinetic energy of object A in terms of the rotational kinetic energy of object B, $K_{\text{rot B}}$?
- A $K_{\text{rot B}}/9$
 - B $3K_{\text{rot B}}$
 - C $9K_{\text{rot B}}$
 - D $K_{\text{rot B}}/3$

13. A solid cylinder with a mass of m and a radius of R is rolling down an incline with an angular speed of ω . The cylinder has rotational kinetic energy K_{rot} . Which of the following is equal to the cylinder's rotational inertia?

- A $\frac{1}{2}mR^2$
- B $\frac{1}{2}m\omega^2$
- C $\frac{K_{\text{rot}}}{m}$
- D $\frac{2K_{\text{rot}}}{\omega^2}$

14. Two blocks with the same mass are moving at the same speed but in opposite directions as shown on the right. Which of the following is true?

- A Both blocks have positive kinetic energy
- B Both blocks have negative kinetic energy
- C The right block has a positive kinetic energy and the left block has a negative kinetic energy
- D The right block has a negative kinetic energy and the left block has a positive kinetic energy

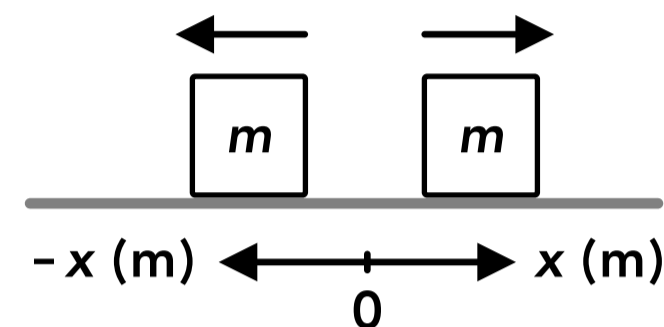

15. Three solid objects are shown on the right. The objects have the same mass and the same width as shown. Object A is rotating at 2 rad/s, object B is rotating at 4 rad/s, and object C is rotating at 3 rad/s. Rank the rotational kinetic energies of the three objects.

- A $K_{\text{rot A}} = K_{\text{rot B}} = K_{\text{rot C}}$
- B $K_{\text{rot B}} < K_{\text{rot C}} < K_{\text{rot A}}$
- C $K_{\text{rot A}} < K_{\text{rot B}} < K_{\text{rot C}}$
- D $K_{\text{rot A}} < K_{\text{rot C}} < K_{\text{rot B}}$

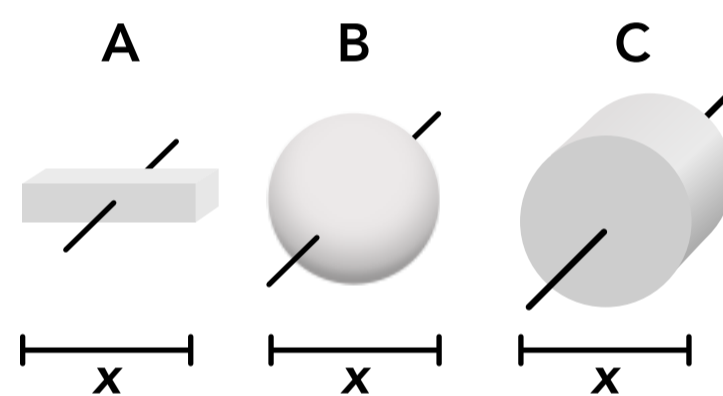

16. A 10 kg block slides down an incline with no friction. When it reaches the bottom of the incline it's moving at 3 m/s. What is the kinetic energy of the block at the bottom of the incline?

17. A ball is falling from some initial height. Just before it hits the ground it has a speed of 6 m/s and 50 J of kinetic energy. What is the mass of the ball?

18. A force causes a 6 kg block to accelerate until it has 100 J of kinetic energy. How fast is the block moving at that moment?
19. A 15 kg ball is dropped from rest from a height of 20 m. After 2 seconds, what is the kinetic energy of the ball?
20. A wheel with a rotational inertia of $500 \text{ kg}\cdot\text{m}^2$ has a rotational kinetic energy of 250 J. What is the angular speed of the wheel?
21. A solid cylinder with a radius of 10 cm and a mass of 8 kg rolls down an incline. When it reaches the bottom it has a linear speed of 2 m/s. What is the rotational kinetic energy of the cylinder at the bottom of the incline?

Gravitational Potential Energy

22. A block is at a height of 5 m above the ground. Which of the following has gravitational potential energy? (Select all that apply)
- A The block
 - B The earth
 - C The block-earth system
 - D None of the above
23. What is the SI unit for gravitational potential energy?
- A m
 - B J
 - C kg
 - D kg·m
24. True or false: gravitational potential energy is a type of mechanical energy.
- A True
 - B False
25. A system consists of two spheres with different masses. The gravitational potential energy of the system depends on which of the following? (Select all that apply)
- A The mass of each sphere
 - B The radius of each sphere
 - C The universal gravitational constant
 - D The distance between the centers of each sphere
26. If two objects move closer together, the gravitational potential energy of the system of the two objects...
- A increases
 - B decreases
 - C stays the same
 - D the change cannot be determined
27. An object falls from a height of 8 m above the ground and lands on a table that is 1 m above the ground. When determining the gravitational potential energy of the object-earth system when the object is at different heights, where do we define the reference height where $y = 0$?
- A At the starting height, 8 m above the ground
 - B At the ending height, 1 m above the ground
 - C At the ground
 - D We can choose any height
28. When using the equation $\Delta U_g = mg\Delta y$ for the change in gravitational potential energy of an object-earth system, which direction must be the positive y direction?
- A Up
 - B Down
 - C We can choose up or down as positive
 - D The positive direction depends on the situation

29. A ball is dropped from an initial height. As it falls, the gravitational potential energy of the ball-earth system...
- A increases
 - B decreases
 - C stays the same
 - D the change cannot be determined

30. A block is attached to a vertical spring and oscillates up and down. Snapshots of the block at different times are shown on the right. At which time does the block-earth system have the greatest gravitational potential energy?

- A Time A
- B Time B
- C Time C
- D The gravitational potential energy is constant

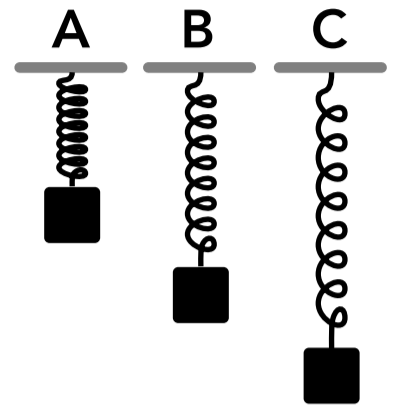

31. A moon is orbiting a planet as shown on the right. Which of the following represents the gravitational potential energy of the planet-moon system?

- A $\frac{Gm_p m_m}{r}$
- B $m_m g r$
- C $-\frac{Gm_p m_m}{r}$
- D $\frac{Gm_p m_m}{r^2}$

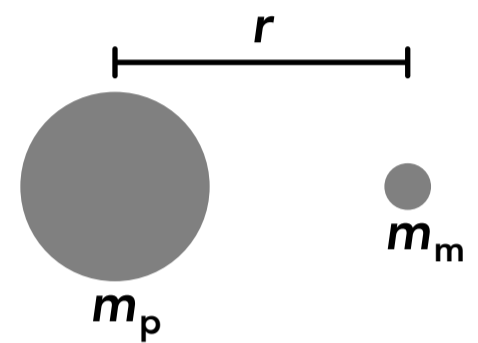

32. Two blocks are at different heights above the ground as shown on the right. If each block falls to the ground, which block (block-earth system) will have the greater change in gravitational potential energy?

- A The 6 kg block
- B The 4 kg block
- C Both blocks will have the same change in gravitational potential energy
- D Cannot be determined

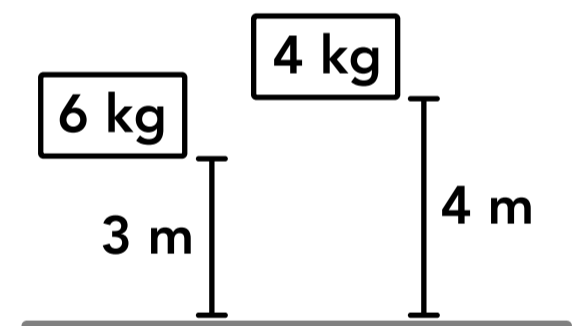

33. A 20 kg ball has 300 J of gravitational potential energy (as a system with the earth). If the system has zero gravitational potential energy when the ball is on the ground, what is the height of the ball?

34. A 4 kg ball rolls off a 1 m high table and lands on the ground. If we say the ball-earth system has zero gravitational potential energy when the ball is on the table, what is the gravitational potential energy of the ball-earth system when the ball is on the ground?

35. The planet Mars has two moons. One of the moons, Phobos, has a mass of 1.07×10^{16} kg and an orbital radius of 9,390 km. If Mars has a mass of 6.39×10^{23} kg, what is the gravitational potential energy of the Mars-Phobos system?

36. A small block is at the top of an incline. The bottom of the incline is defined as the zero reference height for gravitational potential energy. If the gravitational potential energy of the block-earth system is 200 J with the block at the top of the incline, what is the mass of the block?

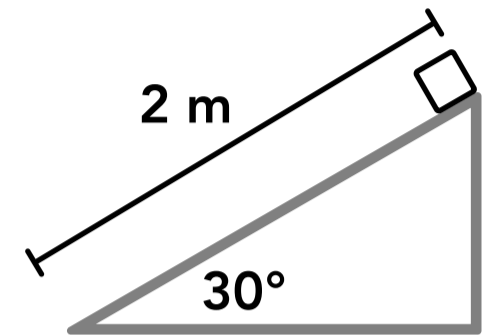

37. A 5 kg block is oscillating up and down on a vertical spring as shown in Figure 1. If we say the zero reference height is the height of the block at position B, what is the gravitational potential energy of the block-earth system when the block is in position A?

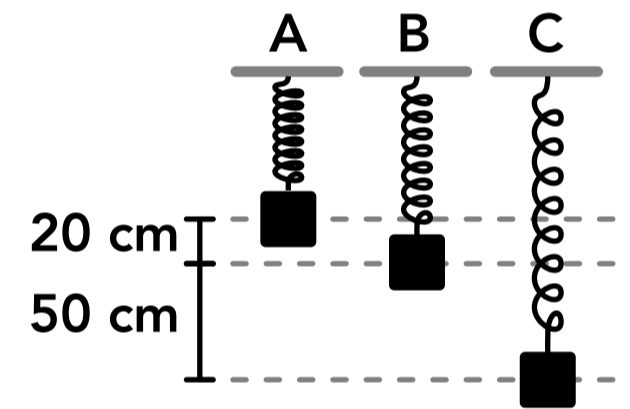

Figure 1

38. A 5 kg block is oscillating up and down on a vertical spring as shown in Figure 1. If we say the zero reference height is the height of the block at position C, what is the gravitational potential energy of the block-earth system when the block is in position A?
39. A 5 kg block is oscillating up and down on a vertical spring as shown in Figure 1. If we say the zero reference height is the height of the block at position B, what is the gravitational potential energy of the block-earth system when the block is in position C?

Spring (Elastic) Potential Energy

40. Which of the following systems have some spring potential energy? (Select all that apply)
- A A block is attached to a vertical spring which is stretched (system: block and spring)
 - B A block is sitting on top of a spring which is compressed (system: only the block)
 - C A block is attached to a vertical spring and is lifted so the spring is not stretched (system: block and spring)
 - D A block slides horizontally into a spring, compressing it (system: block and spring)
41. What is the SI unit for spring potential energy?
- A N/m
 - B N
 - C m
 - D J
42. True or false: spring potential energy is a type of mechanical energy.
- A True
 - B False
43. A block is attached to a horizontal spring which is at its original length. If another force is applied to the block so that the spring gets longer, what happens to the spring potential energy of the block-spring system? If a force is applied so the spring gets shorter instead of longer, what happens to the spring potential energy?
- A It increases / it increases
 - B It increases / it decreases
 - C It decreases / it increases
 - D It decreases / it decreases
44. A block is attached to a horizontal spring with a spring constant of k which is compressed by some amount. If the block-spring system has spring potential energy U_{sp} , which of the following is equal to the distance the spring is compressed?
- A $\frac{2U_{sp}}{k}$
 - B $\frac{k}{2}$
 - C $\sqrt{\frac{2U_{sp}}{k}}$
 - D $2k$
45. Two different blocks are sitting at rest on two different vertical springs, but each spring is compressed the same amount. If spring A has a higher spring constant than spring B, which block-spring system has a greater spring potential energy?
- A Block-spring system A
 - B Block-spring system B
 - C Both systems have the same spring potential energy
 - D Cannot be determined

46. A block with a mass of m is hanging from a vertical spring, and the block-spring system has a spring potential energy of U_{sp} . If the block is replaced with a new block that has a mass of $3m$, what will be the new spring potential energy of the new block-spring system?

- A $3U_{sp}$
- B $9U_{sp}$
- C $U_{sp}/3$
- D $U_{sp}/9$

47. A block is attached to a spring with a spring constant of 100 N/m. The block is at rest on a frictionless surface. What is the spring potential energy of the block-spring system?

- A 5,000 J
- B 1 J
- C 0.5 J
- D None of the above

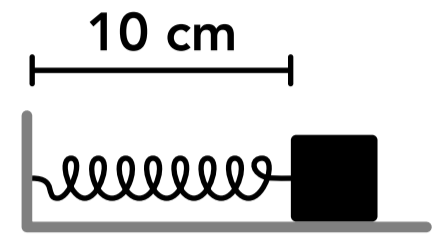

48. A spring is attached to the ceiling and then a block is attached to the bottom of the spring as shown on the right. A force is then applied to the block which moves the block downwards. Which of the following represent the spring potential energy of the block-spring system when the force is applied?

- A $k\Delta y^2$
- B $\frac{1}{2}k\Delta y^2$
- C $\frac{1}{2}k\Delta y$
- D None of the above

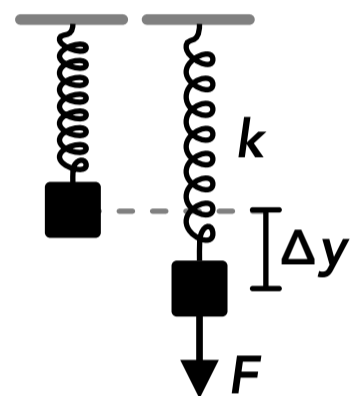

49. A block is attached to a horizontal spring with a length of 20 cm and a spring constant of 150 N/m. The block is pushed so that the new length of the spring is 16 cm. What is the spring potential energy of the system?

50. A block is hung from a vertical spring with a spring constant of 500 N/m. If the spring potential energy of the block-spring system is 10 J, what is the mass of the block?

Answers

- | | | | | |
|------------|---------------|-------------|------------------------------|-------------|
| 1. A, C, D | 11. B | 21. 8 J | 31. C | 41. D |
| 2. C | 12. C | 22. C | 32. A | 42. A |
| 3. B | 13. A, D | 23. B | 33. 1.53 m | 43. A |
| 4. A | 14. A | 24. A | 34. -39.2 J | 44. C |
| 5. A, D | 15. D | 25. A, C, D | 35. -4.86×10^{22} J | 45. A |
| 6. A | 16. 45 J | 26. B | 36. 20.4 kg | 46. B |
| 7. D | 17. 2.78 kg | 27. D | 37. 9.8 J | 47. D |
| 8. B | 18. 5.77 m/s | 28. A | 38. 34.3 J | 48. D |
| 9. C, D | 19. 2,881.2 J | 29. B | 39. -24.5 J | 49. 0.12 J |
| 10. D | 20. 1 rad/s | 30. A | 40. A, D | 50. 10.2 kg |

Answers - Kinetic Energy and Rotational Kinetic Energy

1. **Answer: A, C, D**

An object has kinetic energy (translational kinetic energy) when it is moving (translating) at some speed. A ball falling down, a cylinder rolling down an incline and a ball rolling on the ground are all moving at some speed.

2. **Answer: C**

The SI unit for kinetic energy, and any type of energy, is a joule (J).

3. **Answer: B**

Kinetic energy is a scalar quantity which means it does not have a direction. The direction of the object's velocity does not matter, only the magnitude of the velocity (the speed). An object can only have positive kinetic energy.

4. **Answer: A**

Kinetic energy is a type of mechanical energy, as are gravitational potential energy and spring potential energy.

5. **Answer: A, D**

The equation for kinetic energy is given below. It only depends on the mass and speed of the ball.

$$K = \frac{1}{2}mv^2$$

6. **Answer: A**

Both objects are in projectile motion or free fall, so they both accelerate downwards at the same rate of g , 9.8 m/s^2 , so they both have the same speed at the same moment. If the speeds are the same, the object with more mass will have a greater kinetic energy.

7. **Answer: D**

$$K = \frac{1}{2}mv^2 \quad v = \sqrt{\frac{2K}{m}}$$

8. **Answer: B**

The kinetic energy of an object is directly proportional to the mass and to the square of the speed. If the objects have the same kinetic energy and object B has twice the speed of object A, object B must have 1/4 of the mass of object A.

$$K = \frac{1}{2}mv^2 = \frac{1}{2}\left(\frac{m}{4}\right)(2v)^2$$

9. **Answer: C, D**

An object has rotational kinetic energy when it is in rotational motion and has some angular velocity. The block attached to a spring and the block sliding down an incline are only translating and not rotating.

10. **Answer: D**

The SI unit for rotational kinetic energy, and any type of energy, is a joule (J).

11. **Answer: B**

The equation for rotational kinetic energy is given below. If the objects have the same angular speed then the object with a greater rotational inertia will have a greater rotational kinetic energy. If they spheres have the same mass and radius, the hollow sphere will have a greater rotational inertia.

$$K_{\text{rot}} = \frac{1}{2}I\omega^2 \quad \text{solid sphere: } I = \frac{2}{5}mR^2 \quad \text{hollow sphere: } I = \frac{2}{3}mR^2$$

12. **Answer: C**

Rotational kinetic energy is directly proportional to the square of the angular velocity. If the angular velocity is multiplied by 3, the rotational kinetic energy is multiplied by 9.

$$K_{\text{rot}} = \frac{1}{2}I\omega^2$$

13. **Answer: A, D**

The equation for the rotational inertia of a solid cylinder is: $I = \frac{1}{2}mR^2$

The equation for rotational kinetic energy is: $K_{\text{rot}} = \frac{1}{2}I\omega^2 \quad I = \frac{2K_{\text{rot}}}{\omega^2}$

14. **Answer: A**

Kinetic energy is a scalar quantity (not a vector quantity) which means it does not depend on the direction of the velocity, only the magnitude (speed). Kinetic energy is always positive.

15. **Answer: D**

Each object has a different rotational inertia due to its shape. The radius of objects B and C is $x/2$.

$$\text{Object A: } I = \frac{1}{12}mL^2 = \frac{1}{12}mx^2 \quad K_{\text{rot}} = \frac{1}{2}I\omega^2 = \frac{1}{2} \frac{1}{12}mx^2(2 \text{ rad/s})^2 = \frac{1}{6}mx^2$$

$$\text{Object B: } I = \frac{2}{5}mR^2 = \frac{2}{5}m\left(\frac{x}{2}\right)^2 = \frac{1}{10}mx^2 \quad K_{\text{rot}} = \frac{1}{2}I\omega^2 = \frac{1}{2} \frac{1}{10}mx^2(4 \text{ rad/s})^2 = \frac{4}{5}mx^2$$

$$\text{Object C: } I = \frac{1}{2}mR^2 = \frac{1}{2}m\left(\frac{x}{2}\right)^2 = \frac{1}{8}mx^2 \quad K_{\text{rot}} = \frac{1}{2}I\omega^2 = \frac{1}{2} \frac{1}{8}mx^2(3 \text{ rad/s})^2 = \frac{9}{16}mx^2$$

16. **Answer: 45 J**

$$K = \frac{1}{2}mv^2 = \frac{1}{2}(10 \text{ kg})(3 \text{ m/s})^2 = 45 \text{ J}$$

17. **Answer: 2.78 kg**

$$K = \frac{1}{2}mv^2 \quad (50 \text{ J}) = \frac{1}{2}m(6 \text{ m/s})^2 \quad m = 2.78 \text{ kg}$$

18. Answer: 5.77 m/s

$$K = \frac{1}{2}mv^2 \quad (100 \text{ J}) = \frac{1}{2}(6 \text{ kg})v^2 \quad v = 5.77 \text{ m/s}$$

19. Answer: 2,881.2 J

The ball is in projectile motion or free fall so it accelerates downwards at g , 9.8 m/s^2 . The speed of the ball after 2 seconds can be found using kinematics, which can then be used to find the kinetic energy.

$$v_{yf} = v_{yi} + a_y \Delta t = (0 \text{ m/s}) + (9.8 \text{ m/s}^2)(2 \text{ s}) = 19.6 \text{ m/s}$$

$$K = \frac{1}{2}mv^2 = \frac{1}{2}(15 \text{ kg})(19.6 \text{ m/s})^2 = 2,881.2 \text{ J}$$

20. Answer: 1 rad/s

$$K_{\text{rot}} = \frac{1}{2}I\omega^2 \quad (250 \text{ J}) = \frac{1}{2}(500 \text{ kg}\cdot\text{m}^2)\omega^2 \quad \omega = 1 \text{ rad/s}$$

21. Answer: 8 J

The equation for the rotational inertia of a solid cylinder is: $I = \frac{1}{2}mR^2$

The angular speed of the cylinder is related to its linear speed using this equation: $v = r\omega$. When an object is rolling without slipping, the point on the object in contact with the ground is not moving relative to the ground, so the tangential velocity of points on the perimeter of the cylinder are moving at the same speed as the cylinder itself (the cylinder's center of mass) is moving relative to the ground, which is its linear speed.

$$K_{\text{rot}} = \frac{1}{2}I\omega^2 = \frac{1}{2} \frac{1}{2}(8 \text{ kg})(0.1 \text{ m})^2 \left(\frac{2 \text{ m/s}}{0.1 \text{ m}} \right)^2 = 8 \text{ J}$$

Answers - Gravitational Potential Energy

22. Answer: C

Gravitational potential energy is a property of a two-mass system, a single object cannot have gravitational potential energy on its own. If the system is defined as only the block, the gravitational force acting on the block is an external force and there is no gravitational potential energy in the block system.

23. Answer: B

The SI unit for gravitational potential energy, and any type of energy, is a joule (J).

24. Answer: A

Gravitational potential energy is a type of mechanical energy, as are kinetic energy and spring potential energy.

25. Answer: A, C, D

The gravitational potential energy of a two-mass system depends on the masses, the distance between their centers and the universal gravitational constant. It does not depend on the radius of the objects.

$$U_g = -\frac{GMm}{r}$$

26. **Answer: B**

The equation for the gravitational potential energy of a system of two objects is given below. If the objects get closer together, the distance between their centers (r) decreases. Since the gravitational potential energy is negative, this means the energy decreases (becomes a larger negative value).

$$U_g = -\frac{GMm}{r}$$

27. **Answer: D**

When we use the equation $U_g = mgy$ for the gravitational potential energy of the system relative to when the object is at a reference height of $y = 0$, we can define the reference height anywhere we want. The only value we care about when using that equation is the change in gravitational potential energy between two positions.

28. **Answer: A**

Although we can choose any height to be the reference height where $y = 0$, up must be the positive y direction. An increase in height (when the object moves up) must give us an increase in the gravitational potential energy of the object-earth system, and a decrease in height must give us a decrease in the gravitational potential energy.

29. **Answer: B**

The change in gravitational potential energy is proportional to the change in height of the ball, and up is the positive direction. As the ball falls, the change in height is negative and the change in gravitational potential energy of the ball-earth system is negative.

$$\Delta U_g = mg\Delta y$$

30. **Answer: A**

The gravitational potential energy of the block-earth system is greater when the block is at a greater height.

31. **Answer: C**

This is the equation for the gravitational potential energy of a two-mass system, $U_g = -\frac{GMm}{r}$.

32. **Answer: A**

The change in gravitational potential energy of each system can be found using the equation below.

$$6 \text{ kg block: } \Delta U_g = mg\Delta y = (6 \text{ kg})g(-3 \text{ m}) = -176.4 \text{ J}$$

$$4 \text{ kg block: } \Delta U_g = mg\Delta y = (4 \text{ kg})g(-4 \text{ m}) = -156.8 \text{ J}$$

33. **Answer: 1.53 m**

$$U_g = mgy \quad (300 \text{ J}) = (20 \text{ kg})gy \quad y = 1.53 \text{ m}$$

34. **Answer: -39.2 J**

$$U_g = mgy = (4 \text{ kg})g(-1 \text{ m}) = -39.2 \text{ J}$$

35. **Answer: $-4.86 \times 10^{22} \text{ J}$**

The orbital radius is the distance between the center of Mars and the center of Phobos.

$$U_g = -\frac{GMm}{r} = -\frac{(6.67 \times 10^{-11})(6.39 \times 10^{23} \text{ kg})(1.07 \times 10^{16} \text{ kg})}{(9,390,000 \text{ m})} = -4.86 \times 10^{22} \text{ J}$$

36. **Answer: 20.4 kg**

The height of the block is related to the length and angle of the incline using trigonometry.

$$U_g = mgy \quad (200 \text{ J}) = mg(2 \text{ m})\sin(30^\circ) \quad m = 20.4 \text{ kg}$$

37. **Answer: 9.8 J**

$$U_g = mgy = (5 \text{ kg})g(0.2 \text{ m}) = 9.8 \text{ J}$$

38. Answer: 34.3 J

$$U_g = mgy = (5 \text{ kg})g(0.7 \text{ m}) = 34.3 \text{ J}$$

39. Answer: -24.5 J

$$U_g = mgy = (5 \text{ kg})g(-0.5 \text{ m}) = -24.5 \text{ J}$$

Answers - Spring (Elastic) Potential Energy

40. Answer: A, D

Only a system which includes a spring can have spring potential energy, and the system only has spring potential energy if the spring is stretched or compressed (it is not at its original length).

41. Answer: D

The SI unit for spring potential energy, and any type of energy, is a joule (J).

42. Answer: A

Spring potential energy is a type of mechanical energy, as are kinetic energy and gravitational potential energy.

43. Answer: A

The spring potential energy of an object-spring system is a scalar quantity which is always positive and does not depend on the direction of the spring's displacement. In both scenarios the spring starts at its original length with zero spring potential energy, and then the spring potential energy increases as the spring changes length.

44. Answer: C

$$U_{\text{sp}} = \frac{1}{2}k\Delta x^2 \quad \Delta x = \sqrt{\frac{2U_{\text{sp}}}{k}}$$

45. Answer: A

Spring potential energy is directly proportional to the spring constant. If the springs have the same displacement then the spring with a higher spring constant will have more spring potential energy.

$$U_{\text{sp}} = \frac{1}{2}k\Delta x^2$$

46. Answer: B

The displacement of the spring can be found using Hooke's law, and the weight force from the block is proportional to the displacement of the spring.

$$F_{\text{sp}} = k\Delta y \quad mg = k\Delta y \quad \Delta y = \frac{mg}{k}$$

$$U_{\text{sp}} = \frac{1}{2}k\Delta y^2 = \frac{1}{2}k\left(\frac{mg}{k}\right)^2$$

If the mass is multiplied by 3, the spring potential energy is multiplied by 9 if the spring constant is the same.

47. Answer: D

The block is sitting at rest on a frictionless surface, so the net force on the block must be zero which means the spring force must be zero. The spring is at its original unstretched length so the system has zero spring potential energy.

48. **Answer: D**

Spring potential energy depends on the displacement of the spring from its original unstretched length. The spring is already stretched when the mass is attached, before the force is applied, so the displacement Δy is not the displacement from the original unstretched length of the spring.

49. **Answer: 0.12 J**

$$U_{\text{sp}} = \frac{1}{2}k\Delta x^2 = \frac{1}{2}(150 \text{ N/m})(0.16 \text{ m} - 0.2 \text{ m})^2 = 0.12 \text{ J}$$

50. **Answer: 10.2 kg**

The displacement of the spring can be found using Hooke's law, and the weight force from the block is proportional to the displacement of the spring.

$$F_{\text{sp}} = k\Delta y \quad mg = k\Delta y \quad \Delta y = \frac{mg}{k}$$

$$U_{\text{sp}} = \frac{1}{2}k\Delta y^2 = \frac{1}{2}k\left(\frac{mg}{k}\right)^2 \quad (10 \text{ J}) = \frac{1}{2}(500 \text{ N/m})\left(\frac{mg}{500 \text{ N/m}}\right)^2 \quad m = 10.2 \text{ kg}$$