

CLUE #18

BLOCK NAME	MAKE	GRAYSCALE VERSION	MAIN FABRIC SELECTION	ALTERNATE FABRIC SELECTION
SON OF A PREACHER MAN	3			
OVERVIEW		SPECIAL INSTRUCTIONS		TOOLS
<ul style="list-style-type: none"> <input type="checkbox"/> Son of a Preacher Man Block is made up of 2 sets of Diamond Triangles and (3) 2-Patch Triangles. <input type="checkbox"/> There are two different versions of the Diamond Triangles and one version of 2-Patch Triangles. All of them will be constructed the same. They will be trimmed differently depending on the unit and their placement in the block. 		<ul style="list-style-type: none"> <input type="checkbox"/> Select the FQ Remnants from the previous Block #5. 		Studio 180 Design Star 60™ GENERAL INSTRUCTIONS <ul style="list-style-type: none"> <input type="checkbox"/> HWOFF = Half Width of Fabric, cut from a Fat Quarter, typically 20-21". <input type="checkbox"/> WOF = Width of Fabric, cut selvage to selvage, typically 40-42".
<ul style="list-style-type: none"> <input type="checkbox"/> For tips on this week's block, read this week's Sew on the Go Blog post or Online Class (Clue & Class members only). <input type="checkbox"/> Basic instructions are provided below. If you need additional information, refer to the Star 60 instructions. 				

CUTTING INSTRUCTIONS AND DIRECTIONS WILL PRODUCE: 3 BLOCKS

	UNIT	# OF UNITS	PLACEMENT	FABRIC VALUE	CUT
A	Diamond Triangle LM/BG 	6	Diamond	Light-Med	(1) 2 ¼" x HWOFF Strip*
			Side Triangles	Background	(1) 2 ½" x WOF Strip**
B	Diamond Triangle MD/BG 	12	Diamond	Med-Dark	(2) 2 ¼" x HWOFF Strips
			Side Triangles	Background	(1) 2 ½" x WOF Strip**
C	2-Patch Triangle 	9	Triangle	Background	** Remnants from Units A & B Side Triangles
			Half Hexagon	Light-Med	(1) 2 ¼" x HWOFF Strip plus *Remnant from Unit A Diamond and trim down the wider side of the 4" Remnant of this LM from Block 5.

SUB-CUTTING DIAMONDS

- Gather** the (1) 2 ¼" Light-Med Strip for A Diamonds, and the (2) 2 ¼" Med-Dark Strips for B Diamonds. For the next step, let's start with the Med-Dark Strips.
- Position** the Med-Dark Strips open on the cutting mat and **trim** one short edge at a 60° angle as shown with the edge of the strip on the centerline. Right handed quilters will start at the left side of the strip while left handed quilters will start at the right side. Cut off as little as possible from your strip.



- Position and trim.** Align the Diamond Point Guidelines with the raw edges of the strip and the just trimmed angled cut. Use the 4" Diamond Point guidelines and cut along the leading edge of the tool to create the diamond shapes.

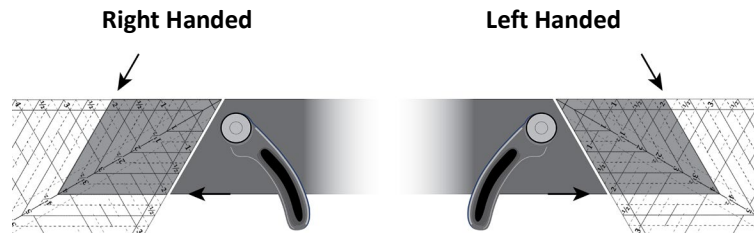

- Continue aligning and cutting until you have (12) Diamonds needed. Assign (12) to Unit B - Diamonds.
- Repeat steps 2-4 with the following strips:
 - Light-Med (1) 2 1/4" Strips, cutting (6) Diamonds for Unit A – Diamonds.

SUB-CUTTING TRIANGLES

- Gather the (2) 2 1/2" Background Strips for Unit A and Unit B Side Triangles.
- Position the Background Strip open on the cutting mat, with the Star 60 tool on top of the fabric. Align the mark near the tip of the tool with the top of the strip and the 2 1/2" horizontal line on the tool with the bottom edge of the strip.

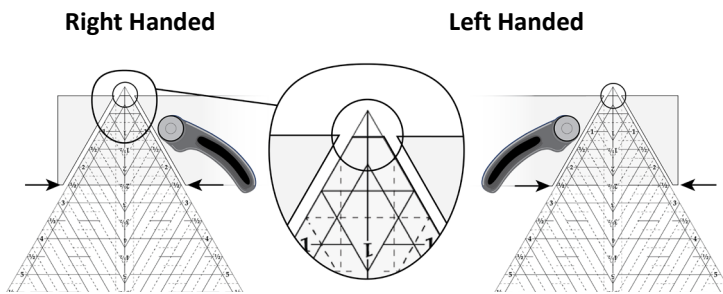

- To cut, right handed quilters will cut from left to right. Left handed quilters will cut from right to left. Cut up one side of the tool and down the other.
- Rotate the Star 60 tool 180° so that the sharp point is closest to you. Align the 2 1/2" horizontal line of the tool with the upper edge of your strip while also aligning one edge of the tool with the previously trimmed edge. Note: the mark near the tip of the tool should align with the bottom of the strip. Cut the next triangle shape from the strip. Continue rotating, aligning, and cutting until you have (45) Side Triangles needed. Assign (12) to Unit A – Side Triangles, (24) to Unit B – Side Triangles, and (9) to Unit C - Triangle.



SUB-CUTTING HALF HEXAGONS

- Gather (1) 2 1/4" Light-Med Strip and remnant strip from Unit A Diamond and the 4" remnant* of this Light-Med from Block 5 Companion Triangle. *Trim the wider side of this 4" strip down to 2 1/4".
- Position the Light-Med Strips open on the cutting mat and position the Star 60 tool on the fabric. Align the bottom edge of the strip with the 4" horizontal line and the top edge of the strip should align with the 1 3/4" horizontal line of the tool.

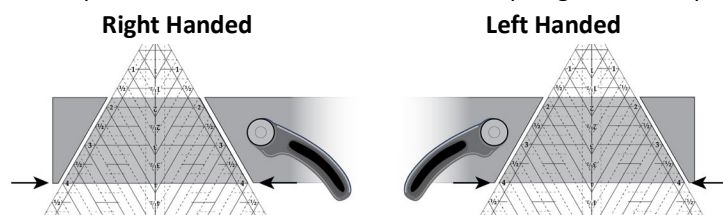

12. **Cut on both sides** of the tool to create the half hexagon. Right handed quilters will cut from left to right. Left handed quilters will cut from right to left.
13. **Rotate** the Star 60 tool 180° and **align** the 4" horizontal line of the tool with the upper edge of your strip while also aligning one edge of the tool with the previously trimmed edge. Continue rotating and cutting until you have (9) Half Hexagons.

Assign (9) to Unit C – Half Hexagons.

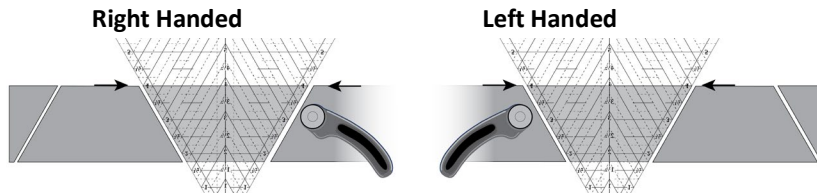

CONSTRUCTING UNITS – UNIT A & B – DIAMOND TRIANGLES

14. **Pair and lay out** the Diamonds with the Side Triangles:
 - **Unit A:** (6) Light-Med Diamonds with (12) Background Side Triangles
 - **Unit B:** (12) Med-Dark Diamonds with (24) Background Side Triangles

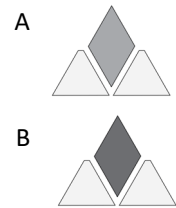

15. **Position and stitch** the Diamond to the left Side Triangle. Take the Diamond and flip it left onto the left Side Triangle. Match the edge of the diamond with the blunt corner of the triangle and **align** the raw edges. **Stitch** with the Diamond on top with your best ¼" seam allowance. **Press** the seam open and **trim** the dog ears to match the Diamond's edge.

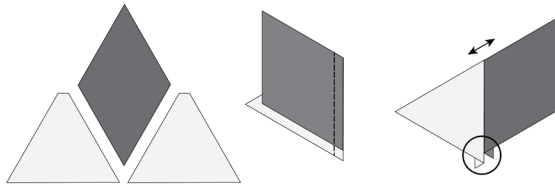

16. **Position and stitch** the remaining Side Triangle on the other side of the Diamond point. **Align** the flat corner of the Side Triangle with the edge of the Diamond. **Align** the raw edges. With the Diamond on top, **stitch** with your best ¼" seam allowance. **Press** the seam open. Repeat for all the units.

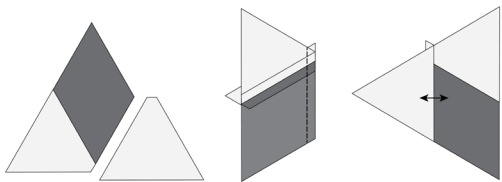

Note: The Diamond Triangle Units will be trimmed depending on their placement and construction in the Bloc. Label and set aside until we get organized..

CONSTRUCTING UNITS - UNIT C - 2-PATCH TRIANGLES

17. **Pair and lay out** the Background Triangles with the Light-Med Half Hexagons.
18. **Position and stitch** the Half Hexagons to the Triangles. Center the Half Hexagon's shorter side with the Triangle's wider side, placing right sides together. Take time to ensure the blunt side of the Triangle is not sewn to the Half Hexagon. Use your best ¼" seam allowance. **Press** the seam open. Repeat for all the units.

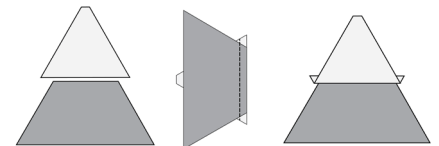

Note: The 2-Patch Triangle Units will be trimmed depending on their placement and construction in the Block; first we must get organized.

TIME TO GET ORGANIZED & TRIM

19. **Organize** the units according to the **chart below**. Once you verify that you have the proper number of each unit, divide the units according to the chart, identifying which side of the unit will be trimmed using the instructions below. Use your placement cards and the [Wonder Clips](#) to label the units. Check out the [Blog](#) for an example of this technique.

	UNIT	TOTAL	TRIM BOTTOM	TRIM TOP (L&R) POINT
A		6	6	
B		12	12	
C		9		9



TRIMMING THE BOTTOM

20. **For all (6) A Units and (12) of the B Units:** position the bottom of the Diamond Triangle Unit on the cutting mat with the bottom facing the right for those that are right handed or the left if you are left handed. Locate and **align** the Flat Edge trim lines on the tool with the seams of the diamond and **trim**. You should be trimming about an $\frac{1}{8}$ - $\frac{1}{4}$ ".

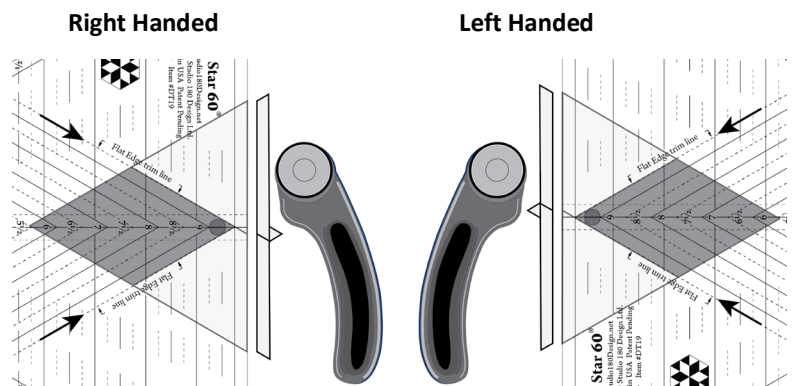

21. **Label with unit and trimmed side.**

TRIMMING THE TOP POINT (LEFT & RIGHT)

22. **For all (9) C Units:** position the 2-Patch Triangle Unit on the cutting mat so that for right handers the blunt top is in the 2 o'clock position or 10 o'clock if you are left handed. **Center** the unit and **align** the seam line of the Triangle and Half Hexagon to the $1\frac{3}{4}$ " guideline. The bottom of the unit **should line up with the $3\frac{3}{4}$ " guideline**. **Trim** both the right and left side of the unit, thereby trimming the blunt top point. You should be trimming about an $\frac{1}{8}$ - $\frac{1}{4}$ " on both sides.

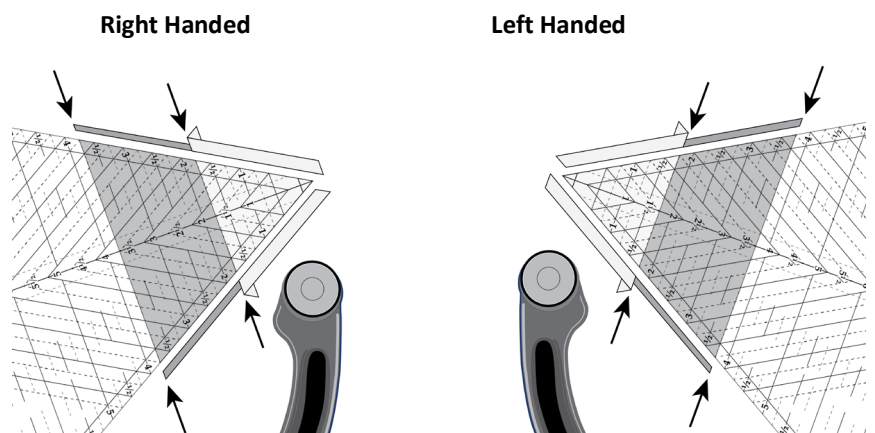

23. **Label with unit and trimmed sides.**

CONSTRUCTING BLOCKS

These Blocks must be constructed in a particular order. It is especially important to follow the steps in the **exact order**. Double check the **orientation** of the unit and ensure you have chosen the unit labeled with the proper cut side. **Tip:** When going through the construction steps, you will always be sewing trimmed sides together. If you find yourself stitching a non-trimmed side, stop and double check that you have the proper unit and that you have it oriented properly.

24. **Gather and position** the (6) A Units (Bottom trimmed) and (12) B Units (Bottom trimmed). **Divide these into two groups.** **Group 1** will have (3) B Units (Bottom trimmed) with (3) more B Units (Bottom trimmed). **Group 2** will have (6) A Units (Bottom trimmed) with (6) B Units (Bottom trimmed). Be careful with this orientation.

25. **Position and stitch.** For Group 1, flip the B Unit onto the B Unit, and for Group 2, flip the B Unit onto the A Unit. For both **line up the trimmed edges and the Diamond Points**. They should be the same shape. **Stitch** with your best $\frac{1}{4}$ " seam allowance. Repeat for all units and **press** the seam open. You should have **(3) Group 1 and (6) Group 2 Diamond Shaped Units**.
26. **Trim** the Unit B. For Group 1, **trim one end of the B Units**. For Group 2, **trim** the B Unit. Position the unit on the cutting mat so that for those that are right handed the B Unit is in the 2 o'clock position or 10 o'clock position if you are left handed. **Align the Unit B Diamond seams with the 3" Diamond Point guidelines, ensuring both points of the Unit B Diamond line up with the center line.** Additionally, the seam intersection between the Units with $3\frac{1}{4}$ " guideline. Trim both sides of the exposed B Unit.

Right Handed

Left Handed

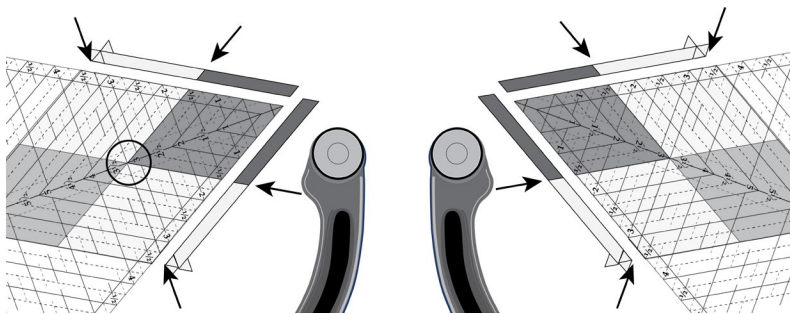

27. **Gather** (6) of the C Units (L&R Point trimmed) and layout as shown with (3) Group 1 Diamond Shaped Units to make a larger Triangle. Make sure the Unit C - Point trimmed units' trimmed sides are positioned towards the diamond shaped units (arrows below identify the sides that are trimmed). The untrimmed side of Unit C should be on the outside of the unit.

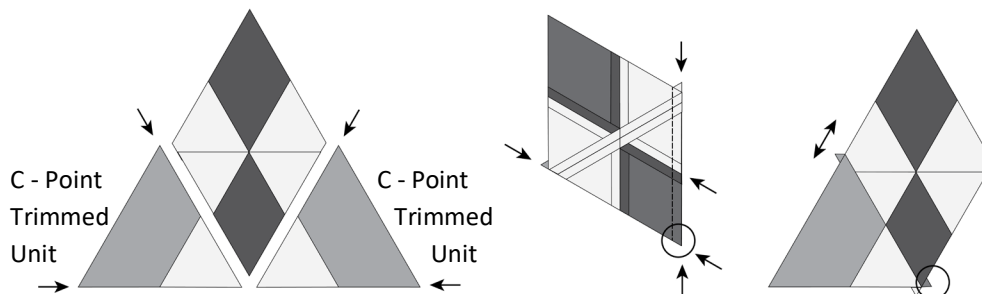

GROUP 1

B – Bottom Trimmed Unit

B – Bottom Trimmed Unit

GROUP 2

A – Bottom Trimmed Unit

B – Bottom Trimmed Unit

28. **Position and stitch** the three units as shown. Start by stitching the diamond shaped unit with the C Unit (L&R Point trimmed) which is on the left. Be careful and **match the seam intersections and the raw edges of the trimmed triangle points**. **Stitch** with your best $\frac{1}{4}$ " seam allowance. Repeat for all units, **press** the seams open and **trim** the dog ear of just the Unit B Background.
29. **Position and stitch** the remaining C Unit (Point trimmed) onto the just sewn unit. Be careful to **align the raw edges of the trimmed triangles, match the Diamond seam intersections**. **Note: Unit C's bottom point should align with the dog ear of the just sewn unit. When you do this, Unit C's top point will lay atop the other dog ear of the unit.** **Stitch** with your best $\frac{1}{4}$ " seam allowance. Repeat for all units, **press** the seams open and **trim** the dog ear. This is the Top Unit. Set aside for now.

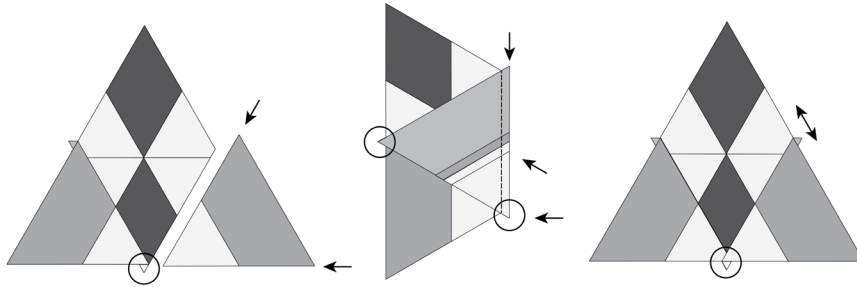

30. **Gather and position** the last (3) C Units (Point trimmed) with the remaining (6) Group 2 Diamond Shaped Units.

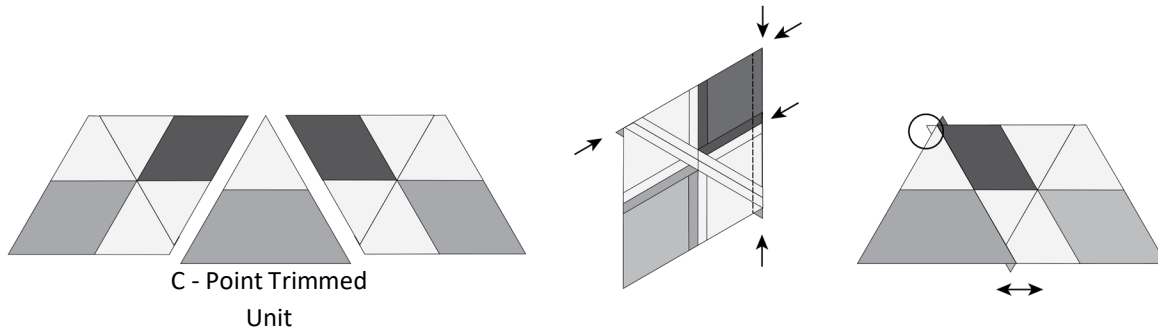

31. **Stitch 3 units together** as shown. Start by stitching the right diamond shaped unit with the individual C Unit (L&R Point Trimmed). Carefully **match the point seam intersections and the raw edges of the trimmed triangle points**. **Stitch** with your best $\frac{1}{4}$ " seam allowance. Repeat for all units. **Press** the seams open and **trim** the dog ear of Unit C Background.
32. **Position and stitch** the just sewn unit onto the remaining diamond shaped unit. Be careful to **match the seam intersections, aligning the raw edges of the trimmed triangles**. **Unit C's dog ear will lay atop the other unit's diamond point**. **Stitch** with your best $\frac{1}{4}$ " seam allowance. Repeat for all units. **Press** the seams open and **trim** the dog ear. These are the Bottom Units.

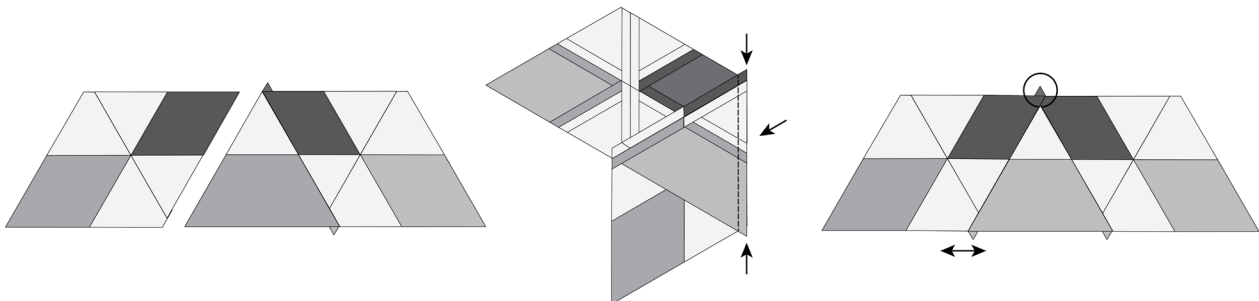

33. Gather the Top Units from step 29 and the Bottom Units that were just sewn.

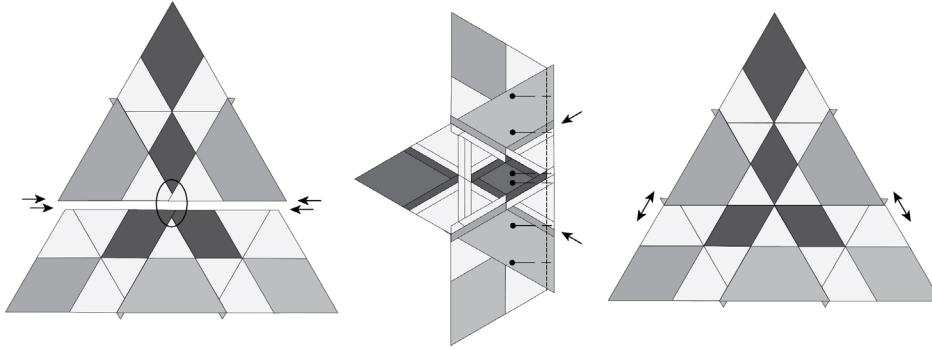

34. **Position and stitch.** Be careful to align the diamond point seam intersections as well as the raw edges of the trimmed triangles. **Stitch** with your best $\frac{1}{4}$ " seam allowance. Repeat for all units. **Press** the seams open.

35. **Trim the blocks.** Position the block on the cutting mat so that the top point is away from you and the bottom side near you. It helps to turn it slightly to 2 o'clock position if you are right handed and to 10 o'clock position if you are left handed. **Align the 3" and 6" Diamond Point guidelines with the seams of the B Unit and A Unit of the block.** **Align the bottom C Unit's seam with the 7 $\frac{3}{4}$ " horizontal guidelines.** **The 3 $\frac{1}{4}$ " and 6 $\frac{1}{4}$ " horizontal guidelines will align with seams as well.** **Trim on both sides of the Block.**

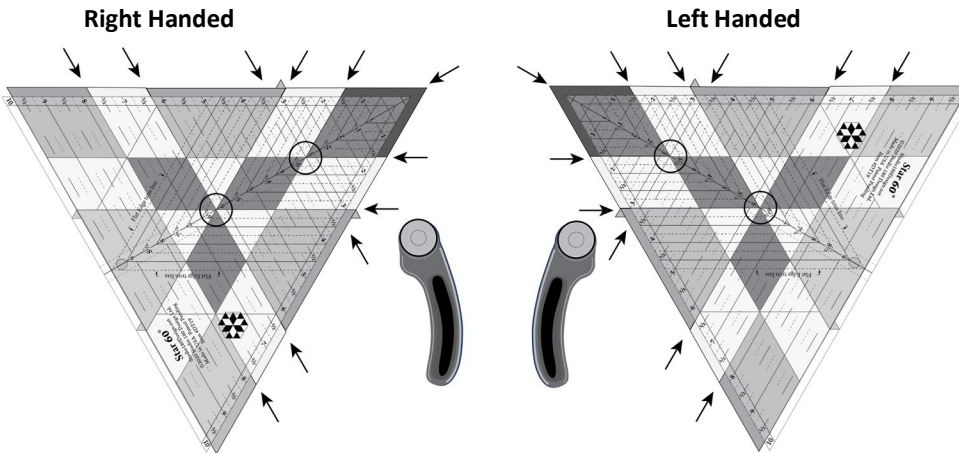

36. **Rotate** the block counter-clockwise for right handed, or clockwise for left handed exposing the untrimmed edge. For those that are right handed, line up the previously trimmed edges of the block, one with the left edge of the Star 60 tool and the other with the 9 $\frac{1}{2}$ " guideline. For those that are left handed, line up the previously trimmed edges of the block, one with the right edge of the Star 60 tool and the other with the 9 $\frac{1}{2}$ " guideline. Note: All the same seam intersections, stated in step 35, will line up as well. **Trim** the remaining side.

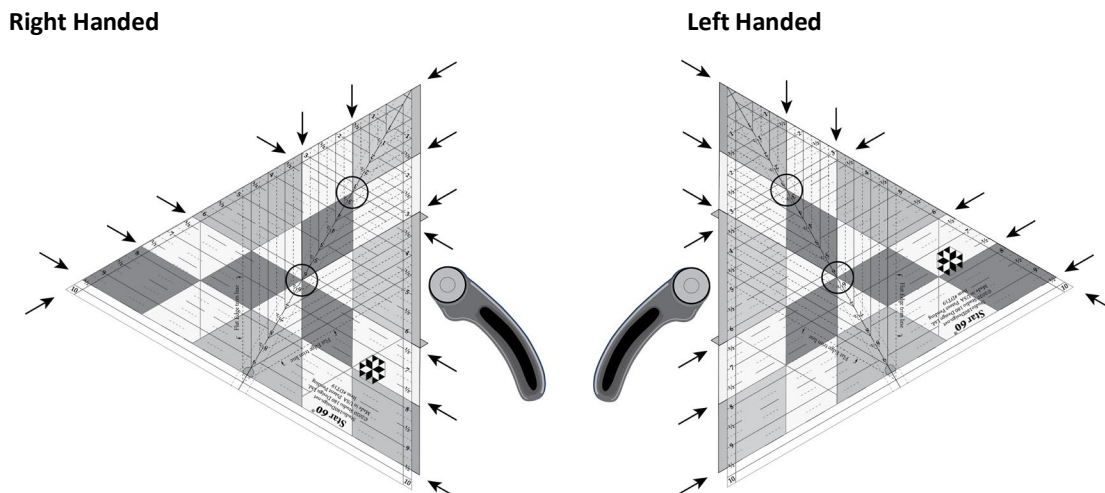

37. **Tada! You made it.** Be sure to post your photos in the [Best of the 60's Facebook Group](#).

ADDITIONAL WORK

38. **Label and go onto the "Group 6" Construction Instructions.** Those instructions are available as a download in your Clue repository (Clue only members) or in your curriculum (Clue and Class members), filed below this Clue.

Please follow the important instructions. In order to best use your fabric, you need to follow these instructions.

IMPORTANT INSTRUCTIONS

- Place the Background Remnant Strips in your storage bag marked "Background scraps". You can use these strips for any block going forward that may require a strip of that same height. Do not cut them down to a different height.
- For each of the fat quarter remnant strips, keep these and place them in your storage bag marked "Fat Quarter scraps".
- Take the remainder of the fat quarters used in this clue, and also place these in your storage bag marked "Fat Quarter scraps".

CLUE #18 RECAP

- Song Trivia – *Son of a Preacher Man*** is a song written and composed by American songwriters John Hurley and Ronnie Wilkins and recorded by British singer Dusty Springfield in September 1968 for the album *Dusty in Memphis*. Springfield's version was produced by Jerry Wexler, Tom Dowd, and Arif Mardin for her first album for the Atlantic Records label and became an international hit reaching #10 in the US and number #9 in her native United Kingdom. The songwriters John Hurley and Ronnie Wilkins wrote the song with Aretha Franklin in mind, according to a 2009 interview with Wilkins. Atlantic Records producer and co-owner Jerry Wexler, who was recording Dusty Springfield's first Atlantic album in Memphis at the time, liked the song and suggested it to Springfield for the *Dusty in Memphis* album. Aretha went on to record it, in 1969, for the B side of her hit single "Call Me".
- [Link to Video](#)

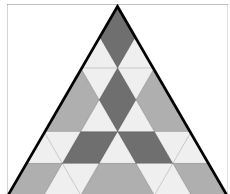
CLUE	BLOCK NAME	GRAYSCALE VERSION	UNIT CUT HEIGHT SIZE	UNIT FINISH HEIGHT SIZE	# OF BLOCKS
#18	Son of a Preacher Man		9 ½"	9"	3