

CLUE #22

BLOCK NAME	MAKE	GRAYSCALE VERSION	MAIN FABRIC SELECTION	ALTERNATE FABRIC SELECTION
BUILD ME UP BUTTERCUP	3			

OVERVIEW	SPECIAL INSTRUCTIONS	TOOLS
<ul style="list-style-type: none"> <input type="checkbox"/> Build Me Up Buttercup Block is made up of (6) Diamond Triangles and (3) 4-Patch Triangles. <input type="checkbox"/> All the Diamond and 4-Patch Triangles will be constructed the same. However, they will be trimmed differently depending on the unit and their placement in the block. 	<ul style="list-style-type: none"> <input type="checkbox"/> Make 3 more Build Me Up Buttercup blocks, using the FQ Remnants from the previous Block #7 	Studio 180 Design Star 60™ GENERAL INSTRUCTIONS <ul style="list-style-type: none"> <input type="checkbox"/> HWOFF = Half Width of Fabric, cut from a Fat Quarter, typically 20-21". <input type="checkbox"/> WOF = Width of Fabric, cut selvage to selvage, typically 40-42".
<ul style="list-style-type: none"> <input type="checkbox"/> For tips on this week's block, check out detailed tips in Clue #11's Sew on the Go Blog post or Online Class (C&C only). <input type="checkbox"/> Basic instructions are provided below. If you need additional information, refer to the Star 60 instructions. 		

CUTTING INSTRUCTIONS AND DIRECTIONS WILL PRODUCE: 3 BLOCKS

	UNIT	# OF UNITS	PLACEMENT	FABRIC VALUE	CUT
A		18	Diamond	Med-Dark	(3) 2 ¼" x HWOFF Strips**
			Side Triangles	Background	(2) 2 ½" x WOF Strips*
B		9	Center Triangle	Med-Dark	(1) 2 ½" x HWOFF Strip**
			Top Triangle	Background	*Remnant from Unit A
			Side Triangles	Light-Med	(2) 2 ½" x HWOFF Strips

** Consider checking your remnant bag to see if you can cut some of your MD Diamonds or MD Center Triangles from remnants.

SUB-CUTTING TRIANGLES

- Gather** the (2) total 2 ½" Background Strips for Unit A Side Triangles and Unit B Top Triangles, the (1) 2 ½" Med-Dark Strip for Unit B Center Triangles, and the (2) 2 ½" Light Medium Strips for Unit B Side Triangles. For the next step, let's start with the Background Strips.
- Position** the Background Strip open on the cutting mat with the Star 60 tool on top of the fabric. **Align the mark near the tip of the tool** with the top of the strips and **the 2 ½" horizontal line on the tool with the bottom edge of the strip.**

Right Handed

Left Handed

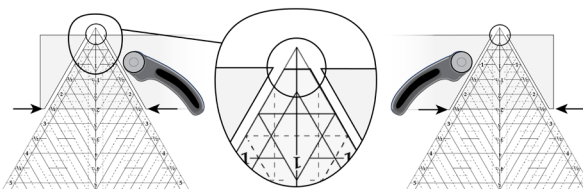

- To cut**, right handed quilters will cut from left to right. Left handed quilters will cut from right to left. Cut up one side of the tool and down the other.

4. **Rotate** the Star 60 tool 180° so that the sharp point is closest to you. **Align the 2 ½" horizontal line of the tool** with the **upper edge of your strip** while also aligning one edge of the tool with the previously trimmed edge. **Note:** the mark near the tip of the tool should **align with the bottom of the strip**. Cut the next triangle shape from the strip. Continue rotating, aligning, and cutting until you have the **(45) Triangles**. **Assign (36) to Unit A – Side Triangles and (9) to Unit B – Top Triangles.**



5. **Repeat** steps 2-4 with the following strips:
- **Med-Dark (1) 2 ½" Strip, cutting (9) Triangles for Unit B – Center Triangles.**
 - **Light-Medium (2) 2 ½" Strips, cutting (18) Triangles for Unit B – Side Triangles.**

SUB-CUTTING DIAMONDS

6. **Gather** the (3) 2 ¼" Med-Dark Strips for Unit A Diamonds.
7. **Position** the Med-Dark Strip open on the cutting mat and trim one short edge at a 60° angle as shown with the edge of the strip on the centerline. Right handed quilters will start at the left side of the strip while left handed quilters will start at the right side. Cut off as little as possible from your strip.

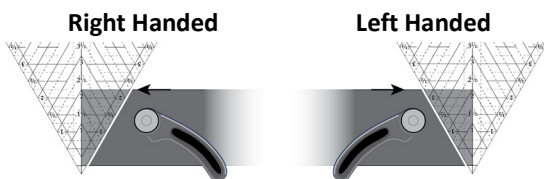

8. **Position and trim.** Align the Diamond Point Guidelines with the raw edges of the strip and the just trimmed angled cut. Use the 4" Diamond Point guidelines and cut along the leading edge of the tool to create the diamond shapes.

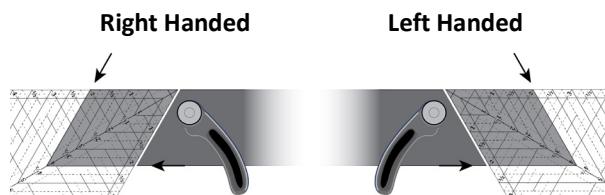

9. **Continue** aligning and cutting until you have (18) Diamonds. **Assign (18) to Unit A – Diamonds.**

CONSTRUCTING UNITS – UNIT A – DIAMOND TRIANGLES

10. **Gather, pair and lay out** the (18) Med-Dark Diamonds with the (36) Background Side Triangles.
11. **Position and stitch** the Diamond to the Left Side Triangle. Take the Diamond and flip it left onto the Left Side Triangle. Match the edge of the diamond with the blunt corner of the triangle and align the raw edges. **Stitch** with the Diamond on top with your best ¼" seam allowance. **Press** the seam open and **trim** the dog ears to match the Diamond's edge. Repeat for all units.
12. **Position and stitch** the remaining Side Triangle on the other side of the Diamond point. **Align** the flat corner of the Side Triangle with the edge of the Diamond. Align the raw edges. With the Diamond on top, **stitch** with your best ¼" seam allowance. **Press** the seam open. Repeat for all the units.

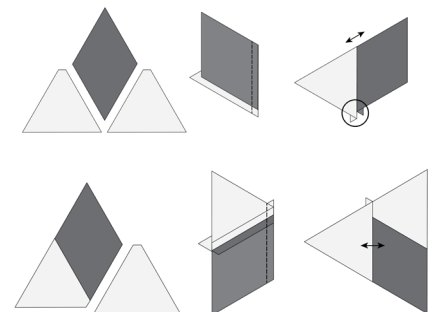

Note: The Diamond Triangle Units will be trimmed depending on their placement and construction in the Block; label and set aside until we get organized.

CONSTRUCTING UNITS – UNIT B - 4-PATCH TRIANGLES

13. **Pair and lay out** (9) of the Background Top Triangles with the (9) Med-Dark Center Triangles. Blunt triangle tips should be in the north and south positions.

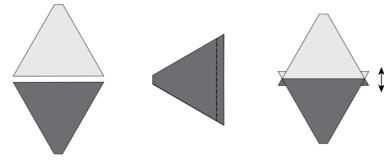

14. **Position and stitch.** Flip the Med-Dark Center Triangle onto the Background Top Triangle, blunt tips should match. **Stitch** with your best 1/4" seam allowance. Repeat for all (9) units and **press** the seam open.

15. **Trim** the Med-Dark Center Triangle. Position the unit on the cutting mat so that for those that are right handed the Med-Dark Center Triangle is in the 2 o'clock position or 10 o'clock position if you are left handed. **Center the diamond shaped unit and align the seam between the triangles with the 1 3/4" guideline.** **Trim** both sides of the exposed Center Triangle Unit. Repeat for all units.

Right Handed

Left Handed

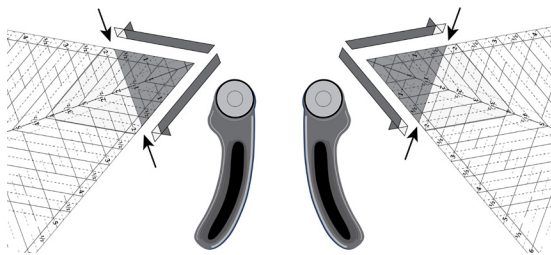

16. **Pair and lay out** the (9) diamond shaped units with the (18) Light-Med Side Triangles.

17. **Position and stitch** the diamond shaped unit to the Left Side Triangle.

Take the diamond shaped unit and flip it left onto the left Side Triangle. Match the edge of the diamond with the blunt corner of the triangle and align the raw edges. **Stitch** with the diamond shaped unit on top with your best 1/4" seam allowance. **Press** the seam open and **trim** the dog ears to match the diamond shaped unit's edge. Repeat for all units.

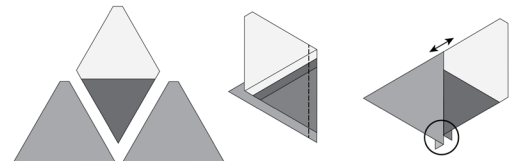

18. **Position and stitch** the remaining Side Triangles on the other side of the half hexagon shaped units. Align the blunt corner of the Side Triangle with the edge of the half hexagon shaped unit. **Align** the raw edges. With the half hexagon shaped unit on top, **stitch** with your best 1/4" seam allowance. **Press** the seam open. Repeat for all the units.

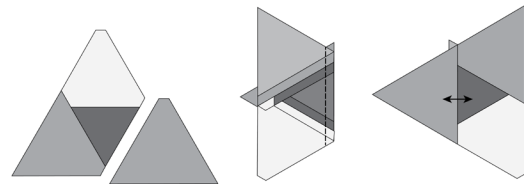

Note: The 4-Patch Triangle Units will be trimmed depending on their placement and construction in the Block; first, let's get organized.

TIME TO GET ORGANIZED & TRIM

19. **Organize** the units according to the **chart below**. First, verify that you have the proper number of each unit. Divide the units according to the chart and identify which side of the unit will be trimmed using the instructions below. Use your placement cards and the [Wonder Clips](#) to label the units. Check out the [Blog](#) for an example of this technique.

	UNIT	TOTAL	TRIM BOTTOM	TRIM TOP (L&R) POINT
A		18	9	9
B		9	9	

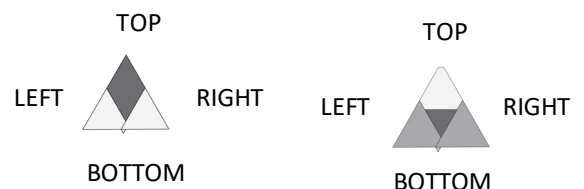

TRIMMING THE BOTTOM – UNIT A

20. For (9) of the A Units: position the Diamond Triangle Unit on the cutting mat with the bottom facing the right for those that are right handed or the left if you are left handed. Locate and align the Flat Edge trim lines on the tool with the seams of the diamond and trim. You should be trimming about an $\frac{1}{8}$ - $\frac{1}{4}$ ".

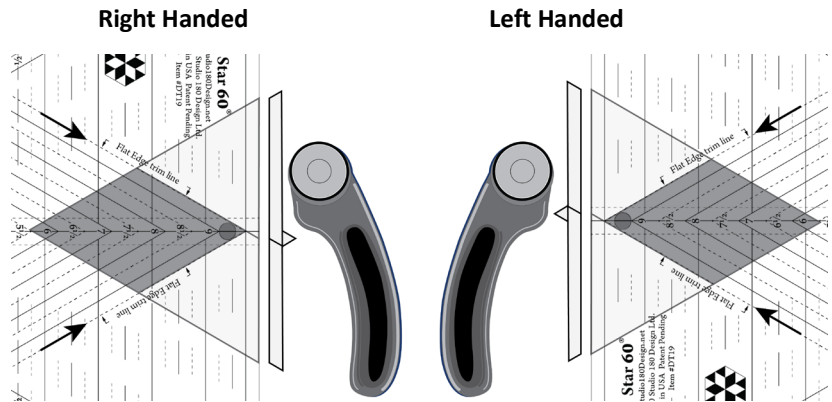

21. Label with unit and trimmed side.

TRIMMING THE TOP POINT (LEFT & RIGHT) – UNIT A

22. For the remaining (9) A Units: position the Diamond Triangle Unit on the cutting mat so that for those that are right handed the top is in the 2 o'clock position or 10 o'clock position if you are left handed. Align the 3" finished size Diamond Point guidelines with the sewn seams. Trim along both sides of the tool. You should be trimming about an $\frac{1}{8}$ - $\frac{1}{4}$ " on both sides. Repeat for all units.

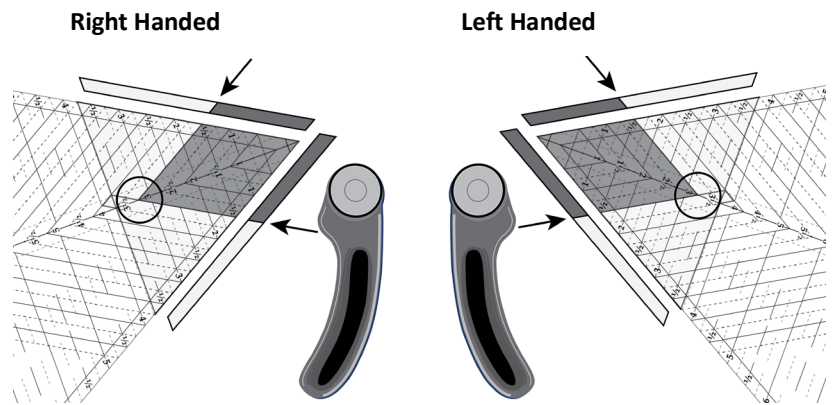

23. Label with unit and trimmed sides.

TRIMMING THE BOTTOM – UNIT B

24. For all (9) B Units: position the bottom of the 4-Patch Triangle Unit on the cutting mat, face the bottom to the right for those that are right handed or the left if you are left handed. Locate and align the Flat Edge trim lines on the tool with the seams of the Center Triangle, forming the bottom of the diamond shape, and trim. You should be trimming about an $\frac{1}{8}$ - $\frac{1}{4}$ ". Repeat for all units.

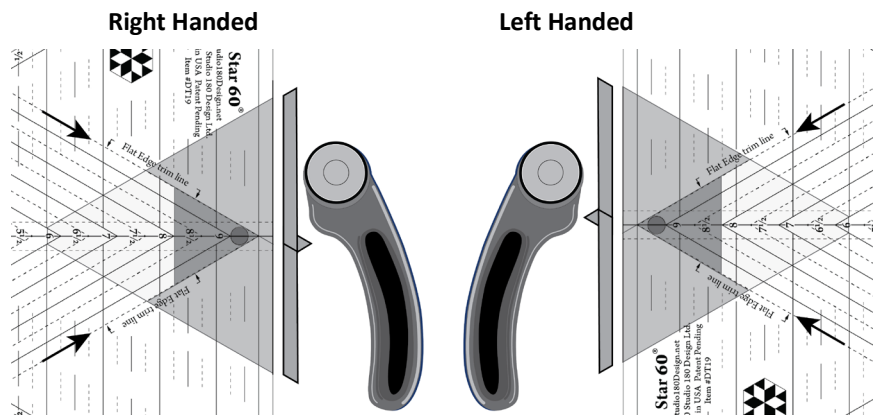

25. Label with unit and trimmed sides.

CONSTRUCTING BLOCKS

These Blocks must be constructed in a particular order. It is especially important to follow the steps in the **exact order**. Double check the **orientation** of the unit and ensure you have chosen the unit labeled with the proper cut side.

Tip: When going through the construction steps, you will always be sewing trimmed sides together. If you find yourself stitching a non-trimmed side, stop and double check that you have the proper unit and that you have it oriented properly.

26. **Gather and position** the (9) A Units (Bottom trimmed) and (9) B Units (Bottom trimmed). Be careful with this orientation. Match the trimmed bottom of the A Unit with the B Unit and align the Diamond Points.

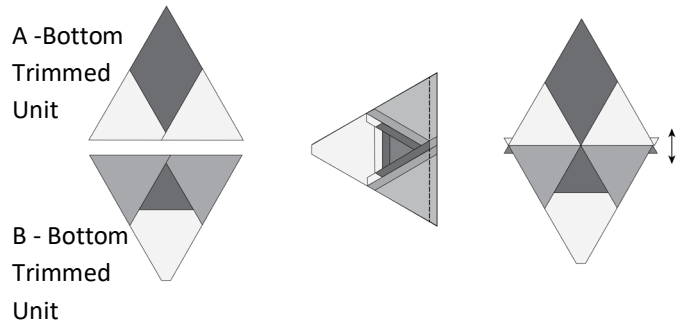

27. **Position and stitch.** Flip the B Unit onto the A Unit; **center the Diamond Points and line up the trimmed edge**. Sew with the B Unit on top, and **stitch** with your best $\frac{1}{4}$ " seam allowance. Repeat for all (9) units and **press** the seam open.
28. **Trim** the B Unit. Position the unit on the cutting mat so that for those that are right handed the B Unit is in the 2 o'clock position or 10 o'clock position if you are left handed. **Align the B Center Triangle seams with the 3" Diamond Point guidelines, and the seam intersection between the A Unit and B Unit with 3 $\frac{1}{4}$ " guideline.** Trim both sides of the B Unit. Repeat for all units.

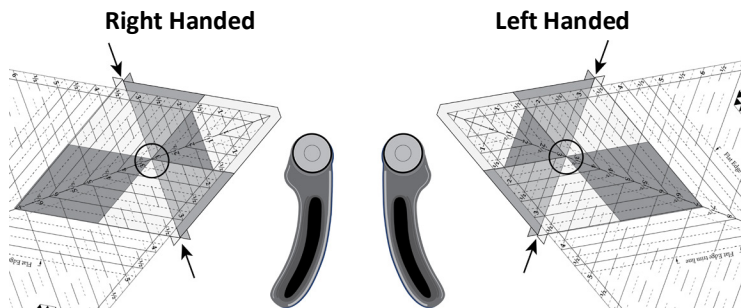

29. **Gather** (6) of the A Units (L&R Point trimmed) and layout as shown with (3) of the diamond shaped units from step 28 to make a larger Triangle. Make sure the A - Point trimmed unit's trimmed sides are positioned towards the diamond shaped units (arrows below identify the sides that are trimmed). The untrimmed side of the A Units should be on the outside of the unit.

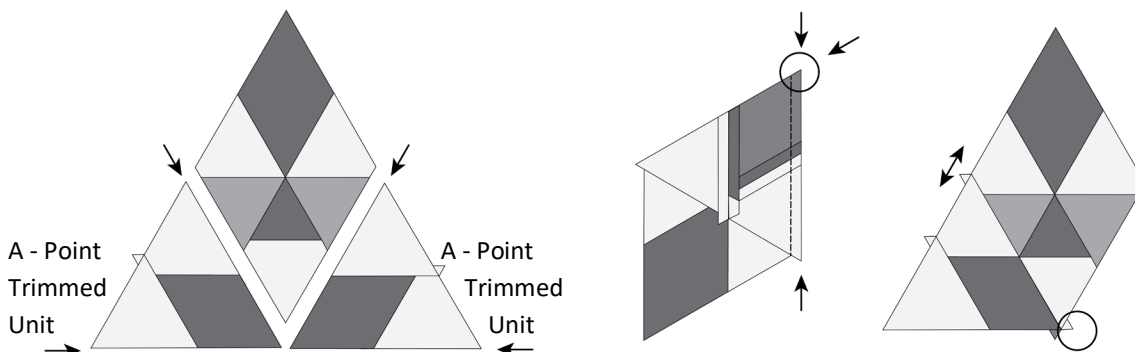

30. **Position and stitch** the three units as shown. Make sure to place the two trimmed sides of the A Unit toward the B Unit of the diamond shape and the bottom. Start by stitching the diamond shaped unit with the A Unit (Point trimmed L&R) which is on the left. Carefully **match the triangle seam intersections and align the raw edges of the trimmed triangle points**. **Stitch** with your best $\frac{1}{4}$ " seam allowance. Repeat for all units. **Press** the seams open and **trim** the dog ear of just the Background of the diamond shape.

31. **Position and stitch** the remaining A Unit (L&R Point trimmed) onto the just sewn unit. Be careful to **match the triangle seam intersections and align the raw edges of the trimmed triangles**. **Note: Unit A's bottom point should align with the dog ear** of the just sewn unit. **Stitch** with your best $\frac{1}{4}$ " seam allowance. Repeat for all units. **Press** the seams open and **trim** the dog ear. This is the Top Unit. Set aside for now.

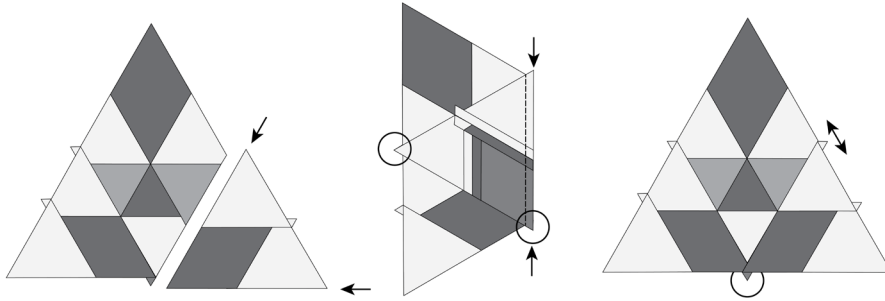

32. **Gather and position** the (3) A Units (L&R Point trimmed) with the (6) diamond shaped units created in step 28.

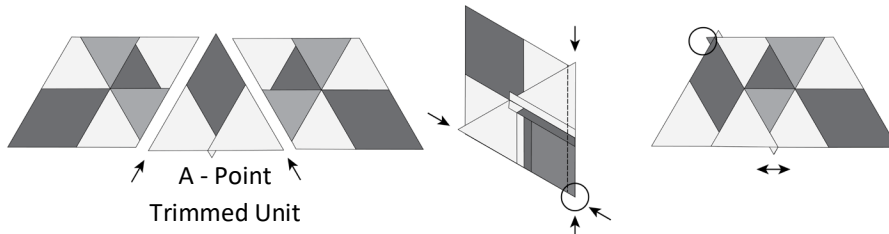

33. **Stitch the three units together** as shown. Start by stitching the diamond shaped unit on the right with the individual A Unit (Point Trimmed L&R). Carefully **match the triangle seam intersections and align the raw edges of the trimmed triangle points**. **Stitch** with the A Unit on top and your best $\frac{1}{4}$ " seam allowance. Repeat for all units. **Press** the seams open and trim the dog ear of the A Unit only.

34. **Position and stitch** the just sewn unit onto the remaining diamond shaped unit. Be careful to **match the triangle seam intersections and align the raw edges of the trimmed triangles**. **Stitch** with your best $\frac{1}{4}$ " seam allowance. Repeat for all units. **Press** the seams open and **trim** the dog ear. These are the Bottom Units.

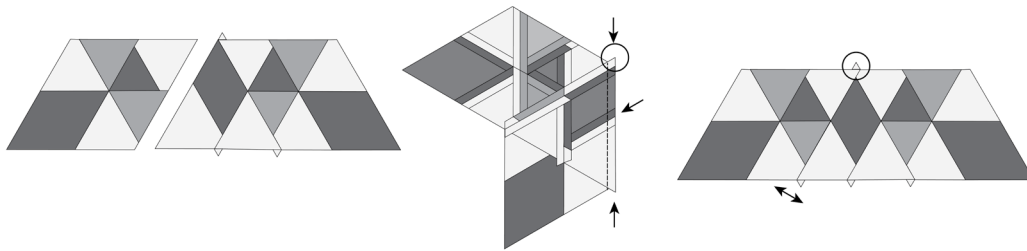

35. **Gather** the Top Units from step 31 and the Bottom Units that were just sewn.

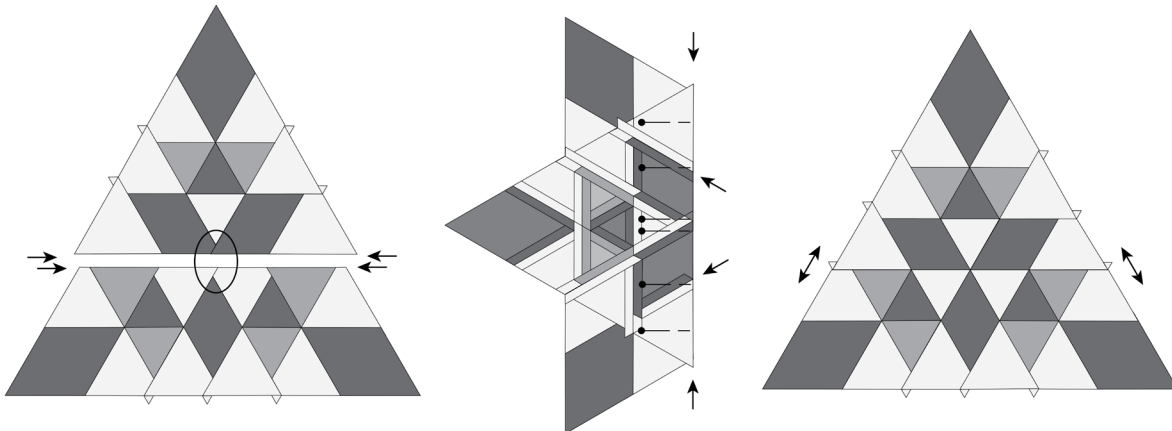

36. **Position and stitch.** Be careful to align the points of the A and B Units, as well as the raw edges of the trimmed triangles. **Stitch** with your best $\frac{1}{4}$ " seam allowance. Repeat for all units. **Press** the seams open.
37. **Trim the blocks.** Position the block on the cutting mat so that the top point is away from you and the bottom side near you. It helps to turn it slightly to 2 o'clock position if you are right handed and to 10 o'clock position if you are left handed. **Align the 3" Diamond Point guidelines with the Unit A on the top, the 6" Diamond Point guidelines with the Unit B, and 9" Diamond Point guidelines with the diamond seams of Unit A on the bottom of the block.** The $3\frac{1}{2}$ " and $6\frac{1}{2}$ " horizontal guidelines will align with seams as well. Trim on both sides of the Block.

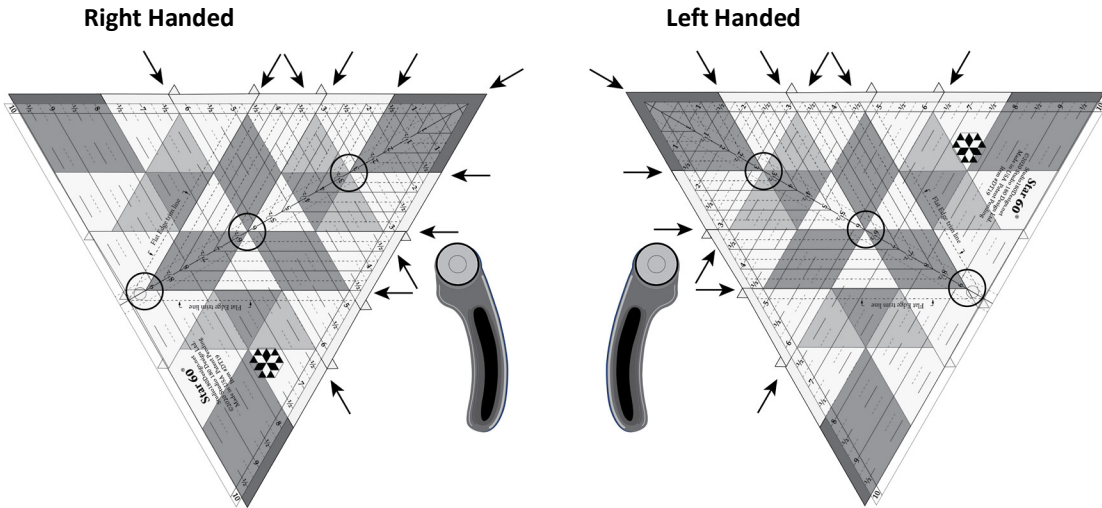

38. **Rotate** the block counter-clockwise for right handed, or clockwise for left handed exposing the untrimmed edge. For those that are right handed, line up the previously trimmed **edges of the block, one with the left edge of the Star 60 tool and the other with the $9\frac{1}{2}$ " guideline.** For those that are left handed, line up the previously trimmed **edges of the block, one with the right edge of the Star 60 tool and the other with the $9\frac{1}{2}$ " guideline.** Note: All the same seam intersections, stated in step 37, will line up as well. **Trim** the remaining side. Repeat for all the blocks.

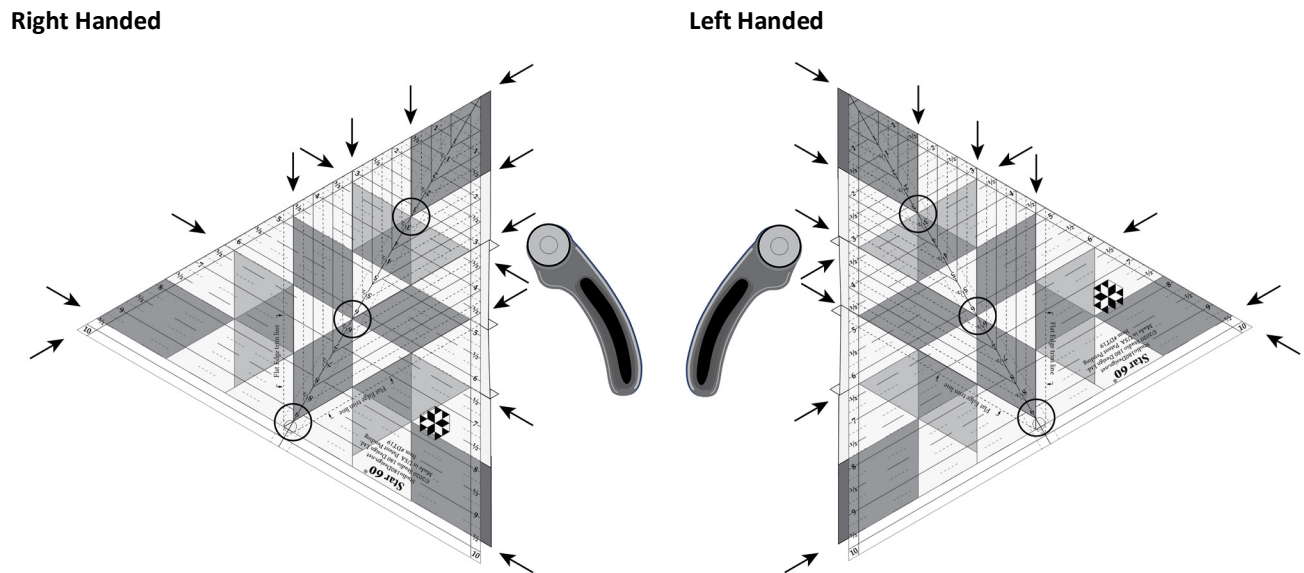

39. **Tada! You made it.** Be sure to post your photos in the [Best of the 60's Facebook Group](#).

ADDITIONAL WORK

40. Label and **go onto the "Group 10" Construction Instructions.** Those instructions are available as a download in your Clue repository (Clue only members) or in your curriculum (Clue and Class members), filed below this Clue.

41. **Additionally, make (2) Billboard Blocks**, utilizing the **"Billboard Block" Instructions**. Those instructions are available as a download in your Clue repository (Clue only members) or in your curriculum (Clue and Class members), filed below this Clue.

Please follow the important instructions. In order to make the best use of your fabric, you need to follow these instructions.

IMPORTANT INSTRUCTIONS

- Place the Background Remnant Strips in your storage bag marked "Background scraps". You can use these strips for any block going forward that may require a strip of that same height. Do not cut them down to a different height.
- For each of the remaining fat quarters used in this clue and fat quarter remnant strips, keep these, and place them in your storage bag marked "Fat Quarter scraps".

CLUE #22 RECAP

- Song Trivia – *Build Me Up Buttercup***, 1968, The Foundations. *Build Me Up Buttercup* was written by Mike d'Abo and Tony Macaulay and released by The Foundations in 1968 with Colin Young singing lead vocals. Young had replaced Clem Curtis during 1968 and this was the first Foundations hit on which he sang. It hit No. 3 on the US Billboard Hot 100 in early 1969. It was also a No. 2 hit in the United Kingdom for two non-consecutive weeks. It was quickly certified Gold by the RIAA for sales of over a million US copies.
- [Link to Video](#)

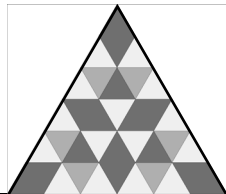
CLUE	BLOCK NAME	GRAYSCALE VERSION	UNIT CUT HEIGHT SIZE	UNIT FINISH HEIGHT SIZE	# OF BLOCKS
#22	BUILD ME UP BUTTERCUP		9 ½"	9"	3