

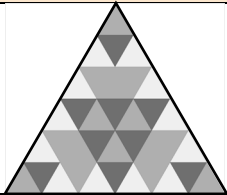
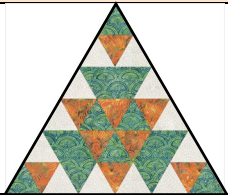
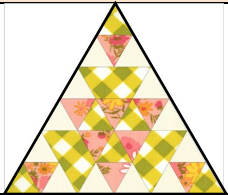

CLUE #23

BLOCK NAME	MAKE	GRAYSCALE VERSION	MAIN FABRIC SELECTION	ALTERNATE FABRIC SELECTION
I HEARD IT THROUGH THE GRAPEVINE	3			

OVERVIEW	SPECIAL INSTRUCTIONS	TOOLS
<ul style="list-style-type: none"> <input type="checkbox"/> I Heard it Through the Grapevine Block is made up of (3) 2-Patch Triangles and (6) 4-Patch Triangle units. <input type="checkbox"/> All the 2-Patch and 4-Patch Triangles will be constructed the same. However, they will be trimmed differently depending on the unit and their placement in the block. 	<ul style="list-style-type: none"> <input type="checkbox"/> Select the FQ Remnants from the previous Block #8. 	Studio 180 Design Star 60™ GENERAL INSTRUCTIONS <ul style="list-style-type: none"> <input type="checkbox"/> HWOFF = Half Width of Fabric, cut from a Fat Quarter, typically 20-21". <input type="checkbox"/> WOF = Width of Fabric, cut selvage to selvage, typically 40-42".
<ul style="list-style-type: none"> <input type="checkbox"/> For tips on this week's block, read this week's Sew on the Go Blog post or Online Class (Clue & Class members only). <input type="checkbox"/> Basic instructions are provided below. If you need additional information, refer to the Star 60 instructions. 		

CUTTING INSTRUCTIONS AND DIRECTIONS WILL PRODUCE: 3 BLOCKS

	UNIT	# OF UNITS	PLACEMENT	FABRIC VALUE	CUT
A	4-Patch Triangle 	18	Center Triangle	Med-Dark	(2) 2 ½" x HWOFF Strips
			Top Triangle	Light-Med	(2) 2 ½" x HWOFF Strips
			Side Triangles	Background	(2) 2 ½" x WOF Strips
B	2-Patch Triangle 	9	Triangle	Med-Dark	(1) 2 ½" x HWOFF Strip
			Half Hexagon	Light-Med	(2) 2 ¼" x HWOFF Strips

SUB-CUTTING TRIANGLES

- Gather** the (3) total 2 ½" Med-Dark Strips for Unit A Center Triangles and Unit B Triangles, (2) 2 ½" Background Strips for Unit A Side Triangles, and (2) 2 ½" Light-Med Strips for Unit A Top Triangles. For the next step, we will start with the Light-Med Strips.
- Position** the Light-Med Strips open on the cutting mat with the Star 60 tool on top of the fabric. **Align the mark near the tip of the tool** with the top of the strips and **the 2 ½" horizontal line on the tool with the bottom edge of the strip.**

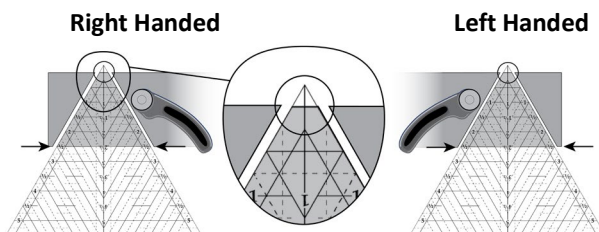

- To cut**, right handed quilters will cut from left to right. Left handed quilters will cut from right to left. Cut up one side of the tool and down the other.
- Rotate** the Star 60 tool 180° so that the sharp point is closest to you. **Align the 2 ½" horizontal line of the tool with the upper edge of your strip** while also aligning one edge of the tool with the previously trimmed edge. **Note:** the mark near

the tip of the tool should **align with the bottom of the strip**. Cut the next triangle shape from the strip. Continue rotating, aligning, and cutting until you have **(18) Triangles**. Assign **(18) to Unit A – Top Triangles**.

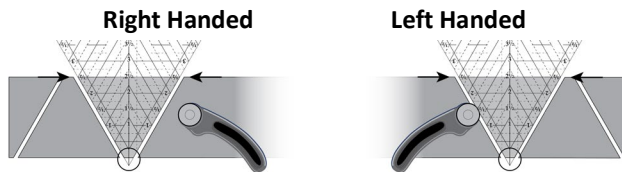

5. Repeat steps 2-4 with the following strips:

- **Background (2) 2 ½" Strips, cutting a total of (36) Triangles. Assign (36) Triangles to Unit A – Side Triangles.**
- **Med-Dark (3) 2 ½" Strips, cutting a total of (27) Triangles. Assign, (18) Triangles to Unit A – Center Triangles and (9) Triangles to Unit B – Triangles.**

SUB-CUTTING HALF HEXAGONS

6. **Gather (2) 2 ¼" Light-Med Strips** for Unit A Half Hexagons.

7. **Position** the Light-Med Strips open on the cutting mat and position the Star 60 tool on the fabric. **Align** the bottom edge of the strip with **the 4" horizontal line** and the top edge of the strip should align with the **1 ¾" horizontal line** of the tool.

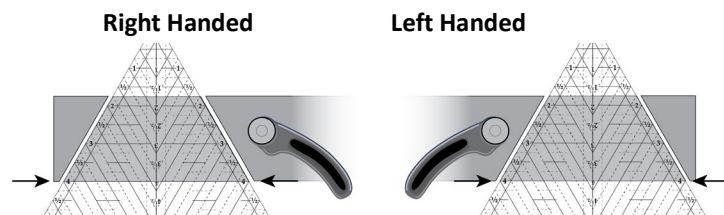

8. **Cut on both sides** of the tool to create the half hexagon. Right handed quilters will cut from left to right. Left handed quilters will cut from right to left.

9. **Rotate** the Star 60 tool 180° and **align** the 4" horizontal line of the tool with the upper edge of your strip while also aligning one edge of the tool with the previously trimmed edge. Continue rotating and cutting until you have the (9) Half Hexagons. **Assign (9) to Unit B – Half Hexagons**.

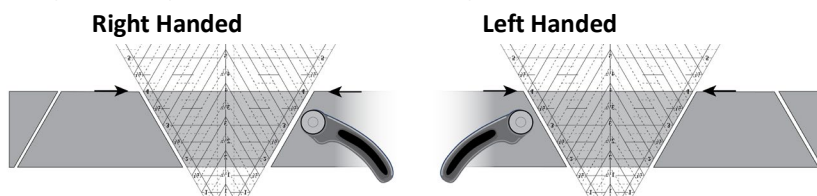

CONSTRUCTING UNITS - UNIT A - 4-PATCH TRIANGLES

10. **Pair and lay out** (18) Light-Med Top Triangles with (18) Med-Dark Center Triangles for Units A. Blunt triangle tips should be in the north and south positions.

11. **Position and stitch**. Flip the Med-Dark Center Triangle onto the Light-Med Top Triangle, blunt tips should match. **Stitch** with your best ¼" seam allowance. Repeat for all (18) units and **press** the seams open.

12. **Trim** the Med-Dark Center Triangles. Position the unit on the cutting mat so that for those that are right handed the Med-Dark Center Triangle is in the 2 o'clock position or 10 o'clock position if you are left handed. **Center the diamond shaped unit and align the seam between the triangles with the 1 ¾" guideline**. **Trim** both sides of the exposed Center Triangle Unit. Repeat for all units.

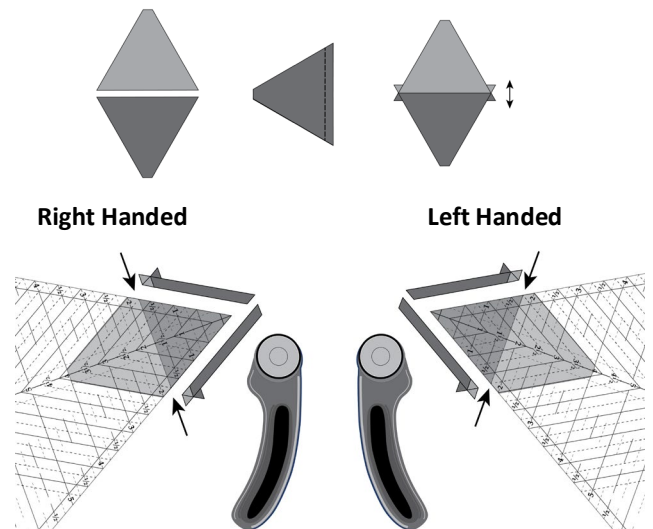

13. **Pair and lay out** the diamond shaped units with the (36) Background Side Triangles.

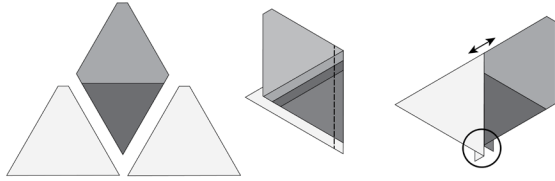

14. **Position and stitch** the diamond shaped unit to the Left Side Triangle. Take the diamond shaped unit and flip it left onto the left Side Triangle. Match the edge of the diamond with the blunt corner of the triangle and align the raw edges. **Stitch** with the diamond shaped unit on top with your best 1/4" seam allowance. **Press** the seams open and trim the dog ears to match the diamond shaped unit's edge. Repeat for all units.

15. **Position and stitch** the remaining Side Triangles on the right side of the half hexagon shaped units. **Align** the blunt corner of the Side Triangle with the edge of the half hexagon shaped unit. **Align** the raw edges. With the half hexagon shaped unit on top, stitch with your best 1/4" seam allowance. **Press** the seams open. Repeat for all the units.

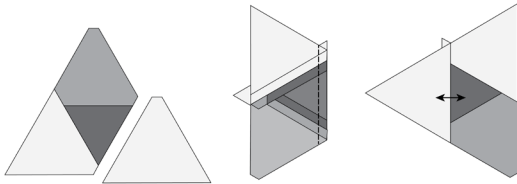

Note: The 4-Patch Triangle Units will be trimmed depending on their placement and construction in the Block. Label and set aside until we get organized.

CONSTRUCTING UNITS - UNIT A - 2-PATCH TRIANGLES

16. **Pair and lay out** the remaining Med-Dark Triangles with the Light-Med Half Hexagons.

17. **Position and stitch** the Half Hexagons to the Triangles. Center the Half Hexagon's shorter side with the Triangle's wider side, placing right sides together. Take time to ensure the blunt side of the Triangle is not sewn to the Half Hexagon. Use your best 1/4" seam allowance. **Press** the seam open. Repeat for all the units.

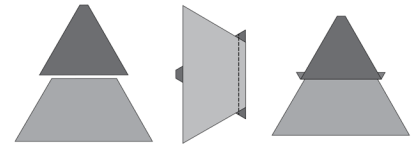

Note: The 2-Patch Triangle Units will be trimmed depending on their placement and construction in the Block; first we must get organized.

TIME TO GET ORGANIZED & TRIM

18. **Organize** the units according to the **chart below**. First, verify that you have the proper number of each unit. Divide the units according to the chart and identify which side of the unit will be trimmed using the instructions below. Use your placement cards and the [Wonder Clips](#) to label the units. Check out the [Blog](#) for an example of this technique.

	UNIT	TOTAL	TRIM BOTTOM	TRIM TOP (L&R) POINT
A		18	9	9
B		9	9	



TRIMMING THE BOTTOM – UNIT A

19. For (9) of the A Units: position the bottom of the 4-Patch Triangle Unit on the cutting mat, face the bottom to the right for those that are right handed or the left if you are left handed. **Locate and align the Flat Edge trim lines** on the tool with the seams of the Center Triangle, forming the bottom of the diamond shape, and **trim**. You should be trimming about an $\frac{1}{8}$ - $\frac{1}{4}$ ". Repeat for all units.
20. **Label with unit and trimmed sides.**

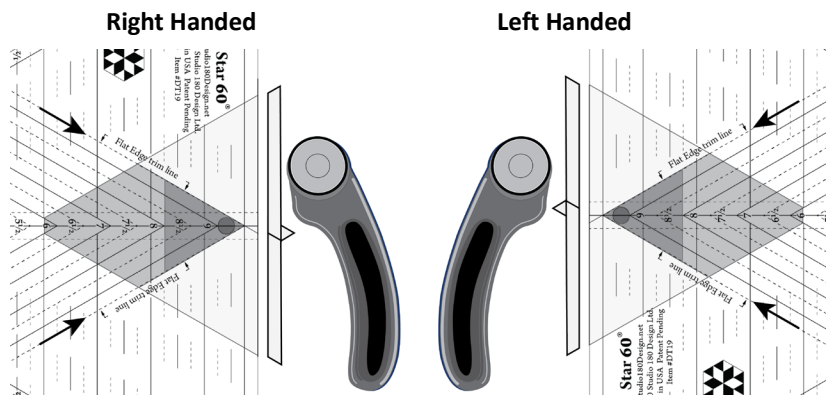

TRIMMING THE TOP POINT (LEFT & RIGHT) – UNIT A

21. For the remaining (9) A Units: position the top triangle with the "top" point on the cutting mat so that for those that are right handed the top is in the 2 o'clock position or 10 o'clock position if you are left handed. **Align the 3" finished size Diamond Point guidelines** with the sewn seams of the bottom of the Center Triangle. **Trim** along both sides of the tool. You should be trimming about an $\frac{1}{8}$ - $\frac{1}{4}$ " on both sides. Repeat for all units.
22. **Label with unit and trimmed sides.**

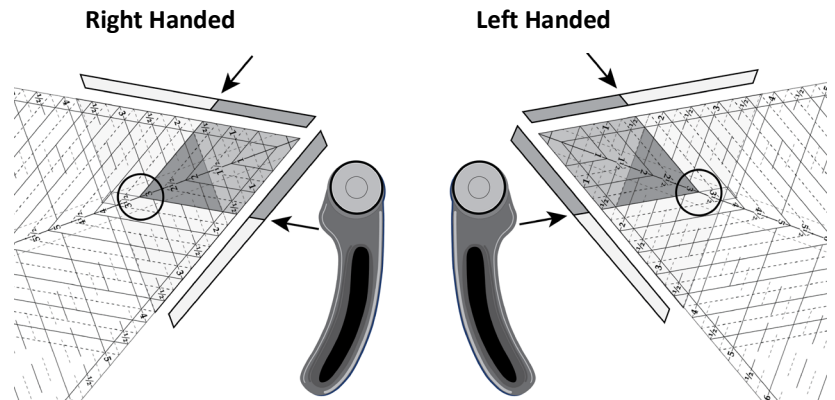

TRIMMING THE BOTTOM – UNIT B

23. For all (9) B Units: position the 2-Patch Triangle Unit on the cutting mat with the bottom facing the right for those that are right handed or the left if you are left handed. **Center the unit and align the seam line of the Triangle and Half Hexagon to the 8 1/4" guideline**. The blunt top of the unit should line up with the 6" guideline. **Trim** the bottom of the triangle. You should be trimming about an $\frac{1}{8}$ - $\frac{1}{4}$ ". Repeat for all the units.
24. **Label with unit and trimmed side.**

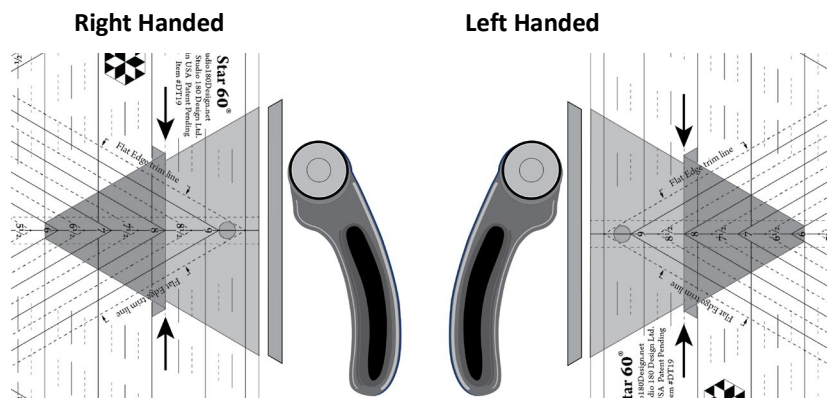

CONSTRUCTING BLOCKS

These Blocks must be constructed in a particular order. It is especially important to follow the steps in the **exact order**. Double check the **orientation** of the unit and ensure you have chosen the unit labeled with the proper cut side. **Tip:** When going through the construction steps, you will always be sewing trimmed sides together. If you find yourself stitching a non-trimmed side, stop and double check that you have the proper unit and that you have it oriented properly.

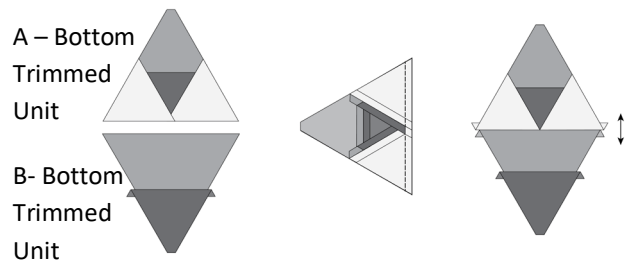

25. **Gather and position** (9) A Units (Bottom trimmed) and (9) B Units (Bottom trimmed). Be careful with this orientation. The A Units should have their trimmed bottom side toward the trimmed bottom of the B Units.
26. **Position and stitch.** Flip the Unit A onto the Unit B; **center and line up the trimmed edges**. Sew with the A Unit on top, and **stitch** with your best $\frac{1}{4}$ " seam allowance. Repeat for all (9) units and **press** the seams open.
27. **Trim** the B Unit. Position the unit on the cutting mat so that for those that are right handed the B Unit is in the 2 o'clock position or 10 o'clock position if you are left handed. **Align the seam intersection between the A Unit and B Unit with the $\frac{3}{4}$ " guideline, while centering the B Unit's diamond point with the centerline.** Trim both sides of the B Unit. Repeat for all the units.

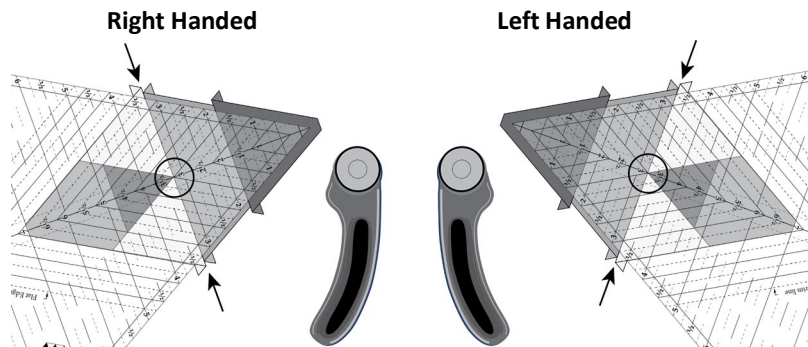

28. **Gather** (6) of the A Units (Point trimmed L&R) and layout as shown with (3) of the diamond shaped units from step 27 to make a larger Triangle. Make sure the B - Point trimmed units' trimmed sides are positioned towards the diamond shaped units (arrows below identify the sides that are trimmed). The untrimmed side of Unit A should be on the outside of the unit.

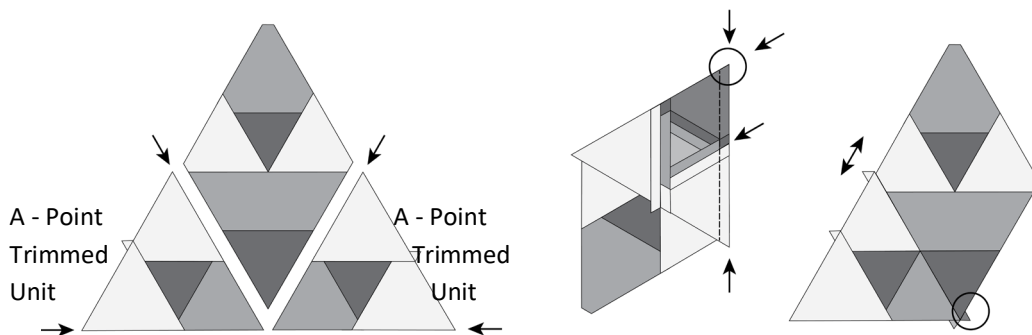

29. **Position and stitch** the three units as shown, make sure to place the two trimmed sides of the Unit A toward the B Unit of the diamond shape and the bottom. Start by stitching the diamond shaped unit with the Unit A (Point trimmed L&R) which is on the left. Carefully **match the triangle seam intersections and align the raw edges of the trimmed triangle points**. To do this, it is recommended that you mark the $\frac{1}{4}$ " line on B Unit's seam line. **Stitch** with your best $\frac{1}{4}$ " seam allowance. Repeat for all units. **Press** the seams open and trim the dog ear of just the Med-Dark of the diamond shape. Repeat for all the units.

30. **Position and stitch** the remaining Unit A (Point trimmed L&R) onto the just sewn unit. Be careful to **match the triangle seam intersections and align the raw edges of the trimmed triangles**. To do this, it is recommended that you mark the ¼" line on B Unit's seam line. **Note: Unit A's bottom point should align with the dog ear of the just sewn unit.** **Stitch** with your best ¼" seam allowance. Repeat for all units. **Press** the seams open and trim the dog ear. This is the Top Unit. Set aside for now.

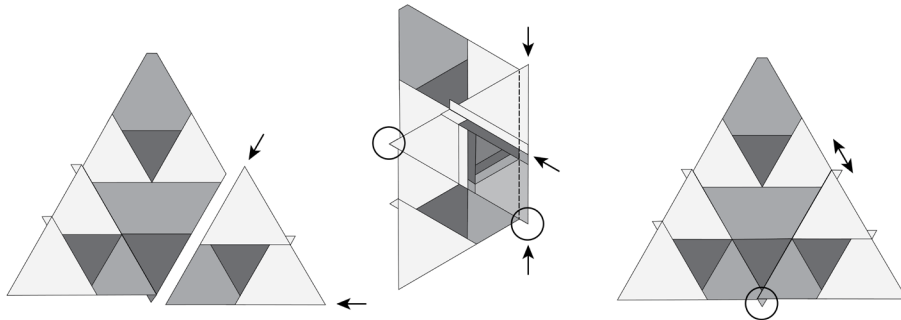

31. **Gather and position** (3) A Units (L&R Point trimmed) with the remaining (6) diamond shaped units created in step 27.

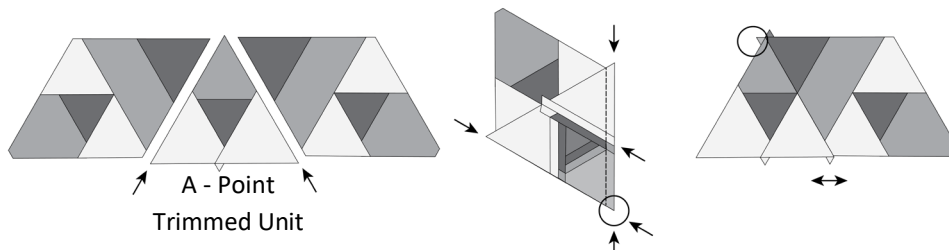

32. **Stitch** the three units together as shown. Start by stitching the diamond shaped unit on the right with the individual A Unit (Point Trimmed). Carefully **match the seam intersections and align the raw edges of the trimmed triangle points**. **Stitch** with the Unit A on top and your best ¼" seam allowance. Repeat for all units. **Press** the seams open and trim the dog ear of the Unit A only.

33. **Position and stitch** the just sewn unit onto the remaining diamond shaped unit. Be careful to **match the seam intersections and align the raw edges of the trimmed triangles**. To do this, it is recommended that you mark the ¼" line on B Unit's seam line. **Stitch** with your best ¼" seam allowance. Repeat for all units. **Press** the seams open and trim the dog ear. These are the Bottom Units.

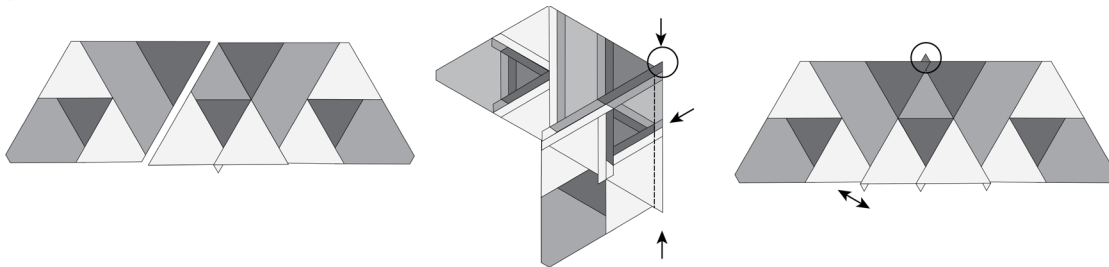

34. **Gather** the Top Units from step 30 and the Bottom Units that were just sewn.

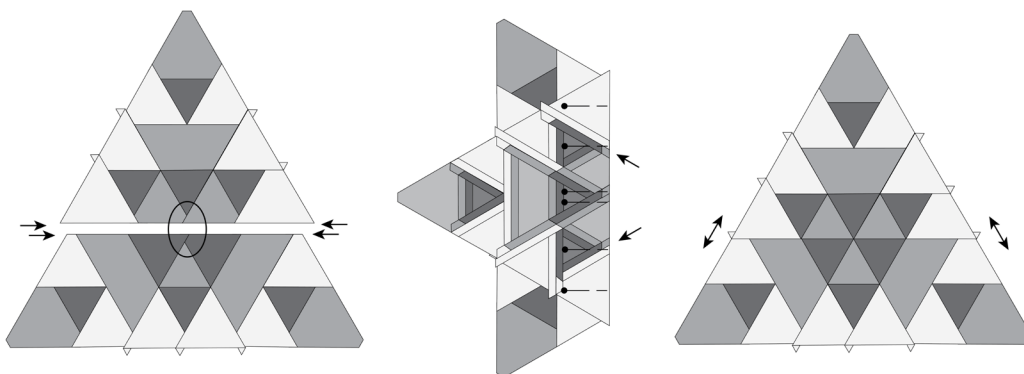

35. **Position and stitch.** Be careful to align all (3) points where the Units A and B line up, as well as the raw edges of the trimmed triangles. **Stitch** with your best $\frac{1}{4}$ " seam allowance. Repeat for all (3) units. **Press** the seams open.
36. **Trim the blocks.** Position the block on the cutting mat so that the top point is away from you and the bottom side near you. It helps to turn it slightly to 2 o'clock position if you are right handed and to 10 o'clock position if you are left handed. **Align the 3" Diamond Point guidelines with Unit A, align Unit B with the 6" Diamond Point guidelines, and the Unit A should align with the 9" Diamond Point guidelines** of the block. Additionally, the seam between the Unit A and bottom of the Unit B should align with the $3\frac{1}{4}$ " horizontal guideline and the seam between the Top and Bottom Units will line up with the $6\frac{1}{4}$ " horizontal guideline. **Trim** both sides of the Block.

Right Handed

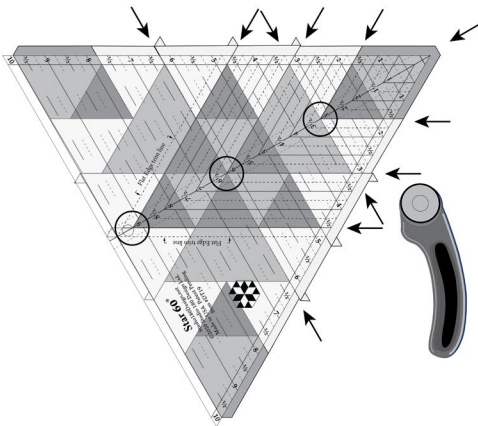

Left Handed

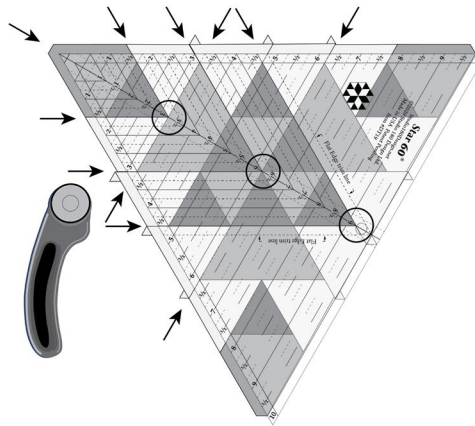

37. **Rotate** the block counter-clockwise for right handed, or clockwise for left handed exposing the untrimmed edge. For those that are right handed, line up the previously trimmed edges of the block, one with the left edge of the Star 60 tool and the other with the $9\frac{1}{2}$ " guideline. For those that are left handed, line up the previously trimmed edges of the block, one with the right edge of the Star 60 tool and the other with the $9\frac{1}{2}$ " guideline. Note: All the same seam intersections, stated in step 36, will line up as well. **Trim** the remaining side. Repeat for all the blocks.

Right Handed

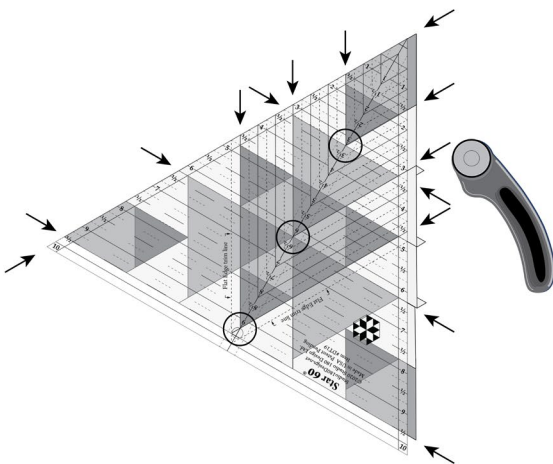

Left Handed

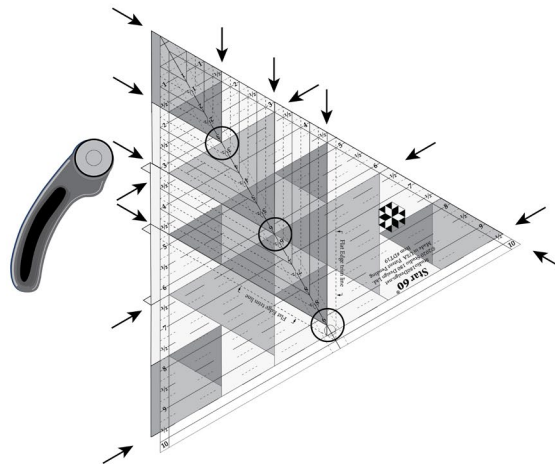

38. **Tada! You made it.** Be sure to post your photos in the [Best of the 60's Facebook Group](#).

ADDITIONAL WORK

39. Label and go to the "Group 11" Construction Instructions. Those instructions are available as a download in your Clue repository (Clue only members) or in your curriculum (Clue and Class members), filed below this Clue.

Please follow the important instructions. In order to make the best use of your fabric, you need to follow these instructions.

IMPORTANT INSTRUCTIONS

- ❑ Place the Background Remnant Strips in your storage bag marked "Background scraps". You can use these strips for any block going forward that may require a strip of that same height. Do not cut them down to a different height.
- ❑ For each of the remaining fat quarters used in this clue and fat quarter remnant strips, keep these, and place them in your storage bag marked "Fat Quarter scraps".

CLUE #23 RECAP

- ❑ **Song Trivia – *I Heard it Through the Grapevine***, was written by Norman Whitfield and Barrett Strong for Motown Records in 1966. The first recording of the song to be released was produced by Whitfield for Gladys Knight & the Pips and released as a single in September 1967. The Marvin Gaye version was the second to be recorded, in the beginning of 1967. It was placed on Marvin Gaye's 1968 album, *In the Groove*, a year and a half later where it gained the attention of radio disc jockeys. Motown founder Berry Gordy finally agreed to its release as a single in October 1968 when it went to the top of the Billboard Pop Singles chart for seven weeks from December 1968 to January 1969, overtaking the Gladys Knight & the Pips' version of being the biggest hit single on the Motown label. The Marvin Gaye recording has since become an acclaimed soul classic. In 1998, the song was inducted to the Grammy Hall of Fame for "historical, artistic and significant" value. In 2004, it was placed 81 on the Rolling Stone list of the 500 Greatest Songs of All Time.
- ❑ [Link to Video](#)

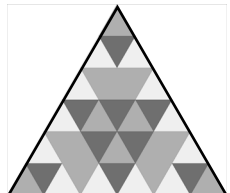
CLUE	BLOCK NAME	GRAYSCALE VERSION	UNIT CUT HEIGHT SIZE	UNIT FINISH HEIGHT SIZE	# OF BLOCKS
#23	I HEARD IT THROUGH THE GRAPEVINE		9 ½"	9"	3