

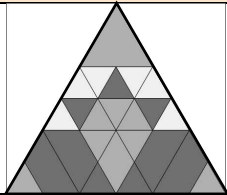

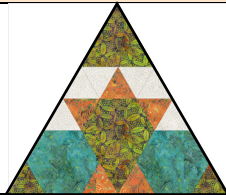

CLUE #20

BLOCK NAME	MAKE	GRAYSCALE VERSION	MAIN FABRIC SELECTION	ALTERNATE FABRIC SELECTION
OH, PRETTY WOMAN	3			
OVERVIEW		SPECIAL INSTRUCTIONS		TOOLS
<ul style="list-style-type: none"> <input type="checkbox"/> Oh, Pretty Woman Block is made up of (3) 4-Patch Triangles, (4) 2-Patch Triangles, (1) Diamond Triangle and (1) Companion Triangle. <input type="checkbox"/> All the 4-Patch, 2-Patch, and Diamond Triangles will be constructed the same. However, they will be trimmed differently depending on the unit and their placement in the block. 		<ul style="list-style-type: none"> <input type="checkbox"/> Make 3 more Oh, Pretty Woman blocks, using the FQ Remnants from the previous Block #11 and **MD Remnant from Block #19 (or any previous Block) 		Studio 180 Design Star 60™ GENERAL INSTRUCTIONS <ul style="list-style-type: none"> <input type="checkbox"/> HWOFF = Half Width of Fabric, cut from a Fat Quarter, typically 20-21". <input type="checkbox"/> WOF = Width of Fabric, cut selvage to selvage, typically 40-42".
<ul style="list-style-type: none"> <input type="checkbox"/> For tips on this week's block, read this week's Sew on the Go Blog Clue or Online Class (Clue & Class members only). <input type="checkbox"/> Basic instructions are provided below. If you need additional information, refer to the Star 60 instructions. 				

CUTTING INSTRUCTIONS AND DIRECTIONS WILL PRODUCE: 3 BLOCKS

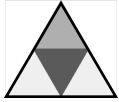
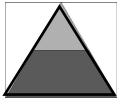
	UNIT	# OF UNITS	PLACEMENT	FABRIC VALUE	CUT
A	4-Patch Triangle 	9	Center Triangle	Med-Dark	(1) 2 ½" x HWOFF Strip
			Top Triangle	Light-Med	(1) 2 ½" x HWOFF Strip*
			Side Triangles	Background	(1) 2 ½" x WOF Strip
B	2-Patch Triangle 	12	Triangle	Light-Med	(1) 2 ½" x HWOFF Strip* *Use the remnant from Unit A Top Triangle
			Half Hexagon	Med-Dark 2**	(3) 2 ¼" x HWOFF Strips ** MD Remnant from Block #19
C	Diamond Triangle 	3	Diamond	Light-Med	(1) 2 ¼" x HWOFF Strip
			Side Triangles	Med-Dark	(1) 2 ½" x HWOFF Strip
D	Companion Triangle 	3	Companion Triangle	Light-Med	(1) 4" x HWOFF Strip

SUB-CUTTING TRIANGLES

- Gather** the (1) 2 ½" Background Strip for Unit A Side Triangles, the (2) total 2 ½" Light-Med strips for Unit A Top Triangles and Unit B Triangles, and the (2) total 2 ½" Med-Dark Strips for Unit A Center Triangles and Unit C Side Triangles. For the next step, let's start with the Light-Medium Strips.

2. **Position** the Light-Med Strips open on the cutting mat with the Star 60 tool on top of the fabric. **Align the mark near the tip of the tool** with the top of the strips and **the 2 ½" horizontal line on the tool with the bottom edge of the strip.**

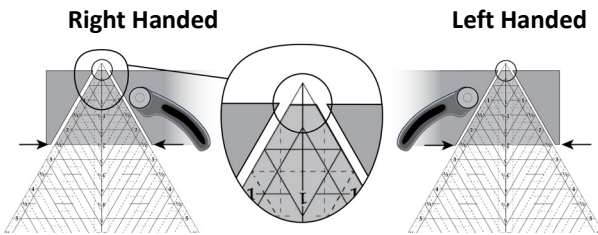

3. **To cut**, right handed quilters will cut from left to right. Left handed quilters will cut from right to left. Cut up one side of the tool and down the other.
4. **Rotate** the Star 60 tool 180° so that the sharp point is closest to you. **Align the 2 ½" horizontal line of the tool with the upper edge of your strip** while also aligning one edge of the tool with the previously trimmed edge. **Note:** the mark near the tip of the tool should **align with the bottom of the strip.** Cut the next triangle shape from the strip. Continue rotating, aligning, and cutting until you have the **(21) Triangles. Assign (9) to Unit A – Top Triangles and (12) to Unit B – Triangles.**



5. **Repeat** steps 2-4 with the following strips:
 - **Background (1) 2 ½" Strip, cutting (18) Triangles for Unit A – Side Triangles.**
 - **Med-Dark (2) 2 ½" Strips, cutting (9) Triangles for Unit A – Center Triangles and (6) Triangles for Unit C – Side Triangles.**

SUB-CUTTING HALF HEXAGONS

6. **Gather** the (3) 2 ¼" Med-Dark 2 Strips (from Remnants) for B Half Hexagons.
7. **Position** the Med-Dark Strips open on the cutting mat and position the Star 60 tool on the fabric. **Align** the bottom edge of the strip with **the 4" horizontal line** and the top edge of the strip should align with the **1 ¾" horizontal line** of the tool.

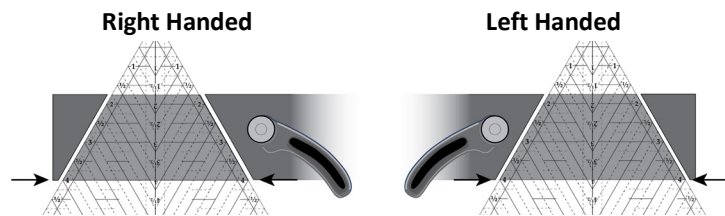

8. **Cut on both sides** of the tool to create the half hexagon. Right handed quilters will cut from left to right. Left handed quilters will cut from right to left.
9. **Rotate** the Star 60 tool 180° and **align** the 4" horizontal line of the tool with the upper edge of your strip while also aligning one edge of the tool with the previously trimmed edge. Continue rotating and cutting until you have the **(12) Half Hexagons. Assign all to Unit B.**

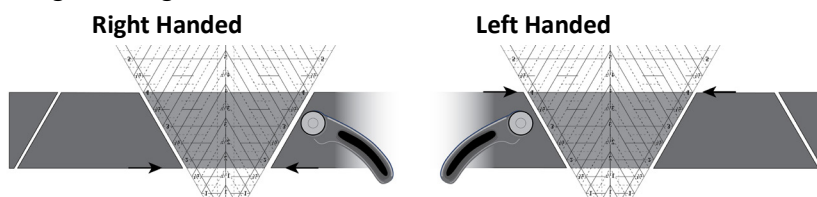

SUB-CUTTING DIAMONDS

10. **Gather** the (1) 2 ¼" Light-Med Strip for Unit C Diamonds.

11. **Position** the Light-Med Strip open on the cutting mat and trim one short edge at a 60° angle as shown with the edge of the strip on the centerline. Right handed quilters will start at the left side of the strip while left handed quilters will start at the right side. Cut off as little as possible from your strip.

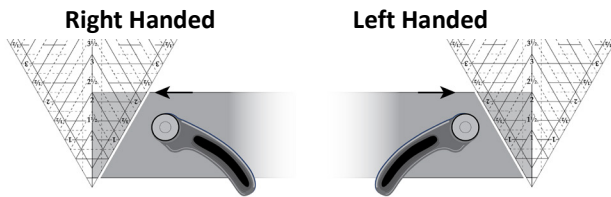

12. **Position and trim.** Align the Diamond Point Guidelines with the raw edges of the strip and the just trimmed angled cut. Use the 4" Diamond Point guidelines and cut along the leading edge of the tool to create the diamond shapes.

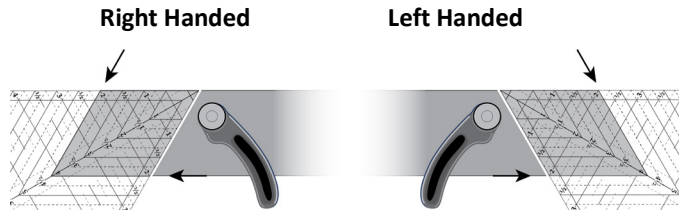

13. **Continue** aligning and cutting until you have (3) Diamonds. **Assign (3) to Unit C – Diamonds.**

SUB-CUTTING COMPANION TRIANGLES

14. **Gather** the (1) 4" Light-Med Strip for Companion Triangles.

15. **Position** the Light-Med Strip open on the cutting mat, with the Star 60 tool on top of the fabric. **Align the mark near the tip of the tool** with the top of the strip and **the 4" horizontal line on the tool on the bottom edge of the strip.**

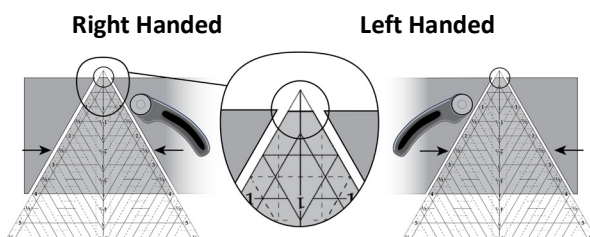

16. **To cut,** right handed quilters will cut from left to right. Left handed quilters will cut from right to left. Cut up one side of the tool and down the other.

17. **Rotate** the Star 60 tool 180° so that the sharp point is closest to you. **Align the 4" horizontal line of the tool** with the **upper edge of your strip** while also aligning one edge of the tool with the previously trimmed edge. **Note:** the mark near the tip of the tool should **align with the bottom of the strip.** Cut the next triangle shape from the strip. Continue rotating, aligning, and cutting until you have (3) Companion Triangles. **These are your D Units.**

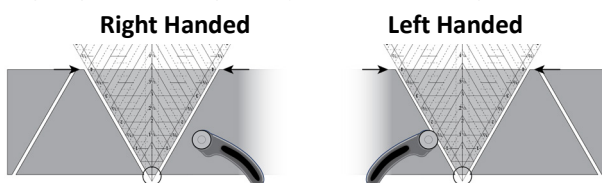

CONSTRUCTING UNITS - UNIT A - 4-PATCH TRIANGLES

18. **Pair and lay out** the (9) Light-Med Top Triangles with the (9) Med-Dark Center Triangles. Blunt triangle tips should be in the north and south positions.

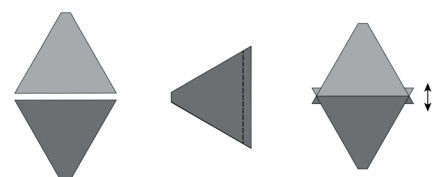

19. **Position and stitch.** Flip the Med-Dark Center Triangle onto the Light-Med Top Triangle, blunt tips should match. **Stitch** with your best $\frac{1}{4}$ " seam allowance. Repeat for all (9) units and **press** the seam open.
20. **Trim** the Med-Dark Center Triangle. Position the unit on the cutting mat so that for those that are right handed the Med-Dark Center Triangle is in the 2 o'clock position or 10 o'clock position if you are left handed. **Center the diamond shaped unit and align the seam between the triangles with the $1\frac{3}{4}$ " guideline.** Trim both sides of the exposed Center Triangle Unit. Repeat for all units.

Right Handed

Left Handed

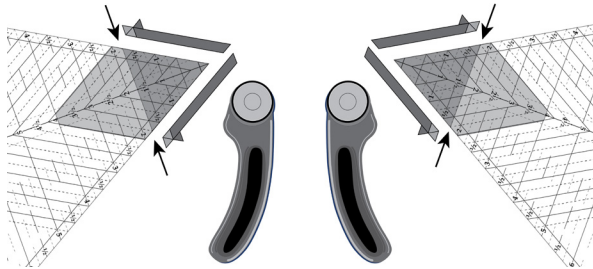

21. **Pair and lay out** the (9) diamond shaped units with the (18) Background Side Triangles.

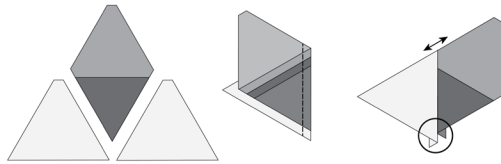

22. **Position and stitch** the diamond shaped unit to the Left Side Triangle. Take the diamond shaped unit and flip it left onto the left Side Triangle. Match the edge of the diamond with the blunt corner of the triangle and align the raw edges. **Stitch** with the diamond shaped unit on top with your best $\frac{1}{4}$ " seam allowance. **Press** the seam open and **trim** the dog ears to match the diamond shaped unit's edge. Repeat for all units.
23. **Position and stitch** the remaining Side Triangles on the other side of the half hexagon shaped units. **Align** the blunt corner of the Side Triangle with the edge of the half hexagon shaped unit. **Align** the raw edges. With the half hexagon shaped unit on top, **stitch** with your best $\frac{1}{4}$ " seam allowance. **Press** the seam open. Repeat for all the units.

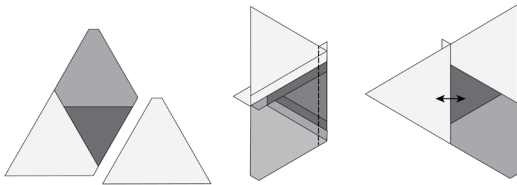

Note: The 4-Patch Triangle Units will be trimmed depending on their placement and construction in the Block; set aside until we get organized.

CONSTRUCTING UNITS - UNIT B - 2-PATCH TRIANGLES

24. **Gather and lay out** (12) Light-Med Triangles with the (12) Med-Dark Half Hexagons.
25. **Position and stitch** the Half Hexagons to the Triangles. Center the Half Hexagon's shorter side with the Triangle's wider side, placing right sides together. Take time to ensure the blunt side of the Triangle is not sewn to the Half Hexagon. Use your best $\frac{1}{4}$ " seam allowance. **Press** the seam open. Repeat for all the units.

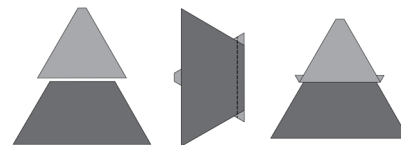

Note: The 2-Patch Triangle Units will be trimmed depending on their placement and construction in the Block; set aside until we get organized.

CONSTRUCTING UNITS – UNIT C – DIAMOND TRIANGLES

26. **Gather, pair and lay out** the (3) Light-Med Diamonds with the (6) Med-Dark Side Triangles.
27. **Position and stitch** the Diamond to the Left Side Triangle. Take the Diamond and flip it left onto the Left Side Triangle. Match the edge of the diamond with the blunt corner of the triangle and align the raw edges. **Stitch** with the Diamond on top with your best 1/4" seam allowance. **Press** the seam open and **trim** the dog ears to match the Diamond's edge. Repeat for all units.
28. **Position and stitch** the remaining Side Triangles on the other side of the Diamond point. **Align** the flat corner of the Side Triangle with the edge of the Diamond. Align the raw edges. With the Diamond on top, **stitch** with your best 1/4" seam allowance. **Press** the seam open. Repeat for all the units.

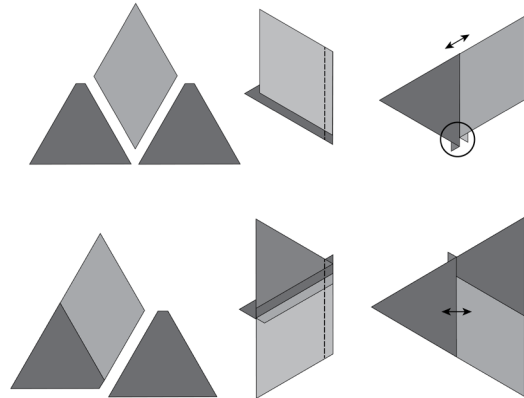

Note: The Diamond Triangle Units will be trimmed depending on their placement and construction in the Block; first we must get organized.

TIME TO GET ORGANIZED & TRIM

29. **Organize** the units according to the **chart below**. Once you verify that you have the proper number of each unit, you will want to divide the units according to the chart, identifying which side of the unit will be trimmed using the instructions below. Use your placement cards and the [Wonder Clips](#) to label the units. Check out the [Blog](#) for an example of this technique.

	UNIT	TOTAL	TRIM BOTTOM	TRIM TOP (L&R) POINT
A		9	3	6
B		12	12	
C		3		3

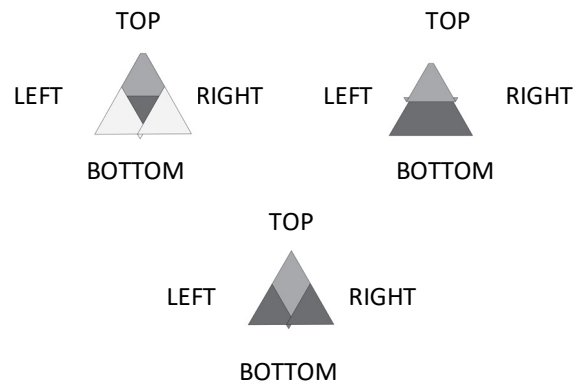

TRIMMING THE BOTTOM – UNIT A

30. **For (3) of the A Units:** position the bottom of the 4-Patch Triangle Unit on the cutting mat, face the bottom to the right for those that are right handed or the left if you are left handed. **Locate and align the Flat Edge trim lines** on the tool with the seams of the Center Triangle, forming the bottom of the diamond shape, and **trim**. You should be trimming about an 1/8 - 1/4". Repeat for all units.

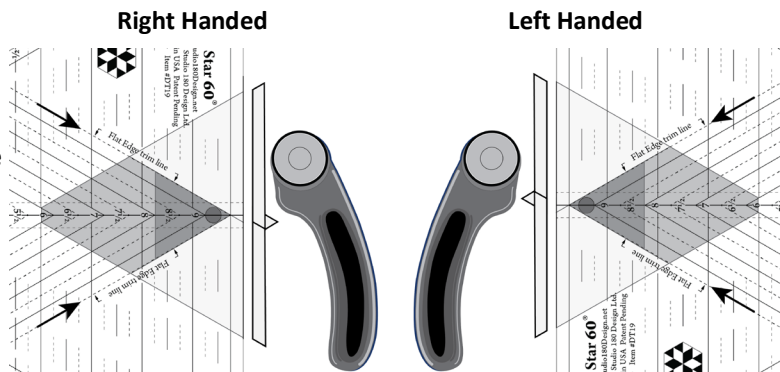

31. Label with unit and trimmed sides.

TRIMMING THE TOP POINT (LEFT & RIGHT) – UNIT A

32. For the remaining (6) A Units: position the top triangle with the “top” point, on the cutting mat so that for those that are right handed the top is in the 2 o’clock position or 10 o’clock position if you are left handed. **Align the 3” finished size Diamond Point guidelines** with the sewn seams of the bottom of the Center Triangle. **Trim** along both sides of the tool. You should be trimming about an 1/8 - 1/4” on both sides. Repeat for all units.

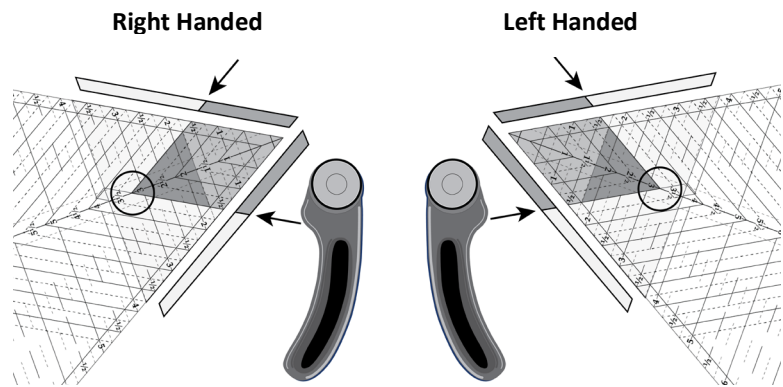

33. Label with unit and trimmed sides.

TRIMMING THE BOTTOM – UNIT B

34. For all (12) of the B Units: position the 2-Patch Triangle Unit on the cutting mat with the bottom facing the right for those that are right handed or the left if you are left handed. **Center** the unit and **align the seam line of the Triangle and Half Hexagon to the 8 3/4” guideline**. The blunt top of the unit should line up with the 6” guideline. **Trim** the bottom of the triangle. You should be trimming about an 1/8 - 1/4”. Repeat for all units.

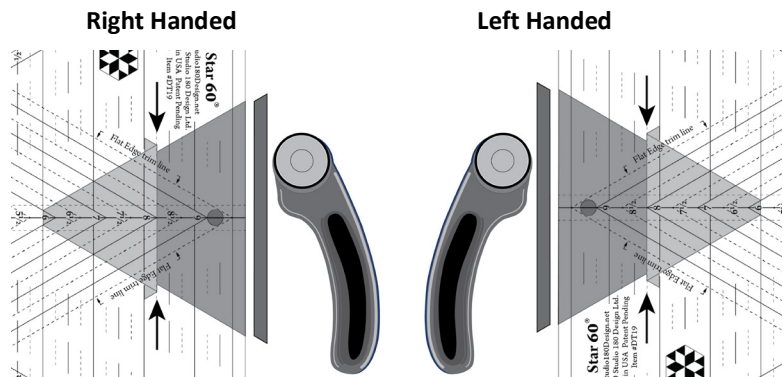

35. Label with unit and trimmed side.

TRIMMING THE TOP POINT (LEFT & RIGHT) – UNIT C

36. For the (3) C Units: position the Diamond Triangle Unit on the cutting mat so that for those that are right handed the top is in the 2 o’clock position or 10 o’clock position if you are left handed. **Align the 3” finished size Diamond Point guidelines** with the sewn seams. **Trim** along both sides of the tool. You should be trimming about an 1/8 - 1/4” on both sides. Repeat for all units.

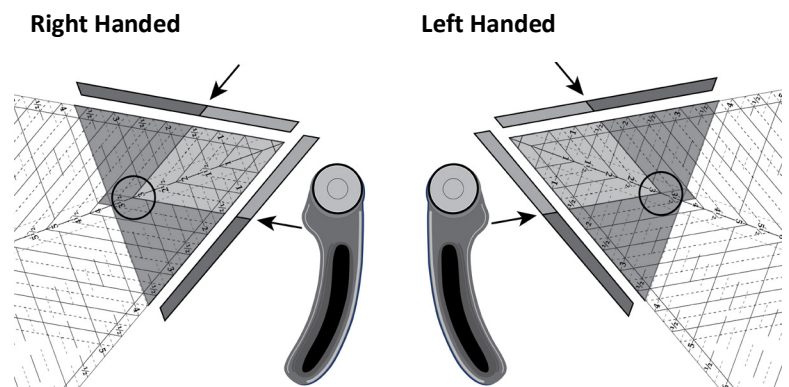

37. Label with unit and trimmed sides.

CONSTRUCTING BLOCKS

These Blocks must be constructed in a particular order. It is especially important to follow the steps in the **exact order**. Double check the **orientation** of the unit and ensure you have chosen the unit labeled with the proper cut side.

Tip: When going through the construction steps, you will always be sewing trimmed sides together. If you find yourself stitching a non-trimmed side, stop and double check that you have the proper unit and that you have it oriented properly.

38. **Gather and position** the (3) Light-Med Companion Triangles and (3) of the A Units (Bottom trimmed). Be careful with this orientation. Match the trimmed bottom of the A Unit with the Companion Triangle side opposite the blunt tip.

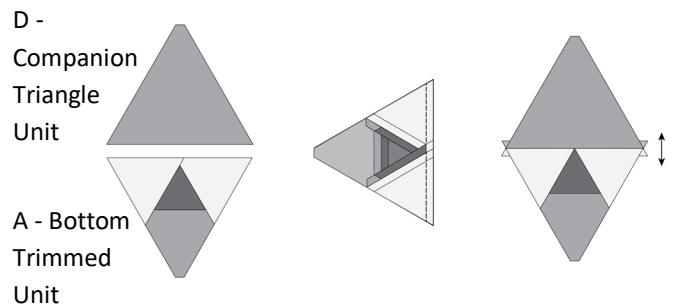

39. **Position and stitch.** Flip the A Unit onto the D Unit; **center and line up the trimmed edge**. Sew with the A Unit on top, and **stitch** with your best $\frac{1}{4}$ " seam allowance. Repeat for all units and **press** the seam open.

40. **Trim** the A Unit. Position the unit on the cutting mat so that for those that are right handed the A Unit is in the 2 o'clock position or 10 o'clock position if you are left handed. **Align the A Center Triangle seams with the 3" Diamond Point guidelines, and the seam intersection between the A Unit and D Unit with 3 $\frac{1}{4}$ " guideline.** Trim both sides of the A Unit. Repeat for all units.

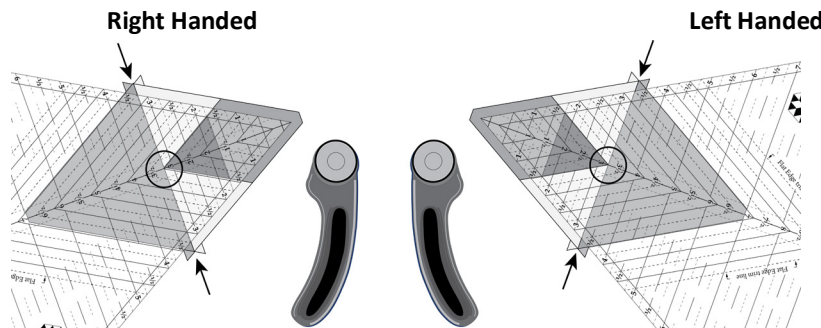

41. **Gather** the remaining (6) A Units (L&R Point trimmed) and layout as shown with (3) of the diamond shaped units from step 40 to make a larger Triangle. Make sure the A - Point trimmed unit's trimmed sides are positioned towards the diamond shaped units (arrows below identify the sides that are trimmed). The untrimmed side of the A Units should be on the outside of the unit.

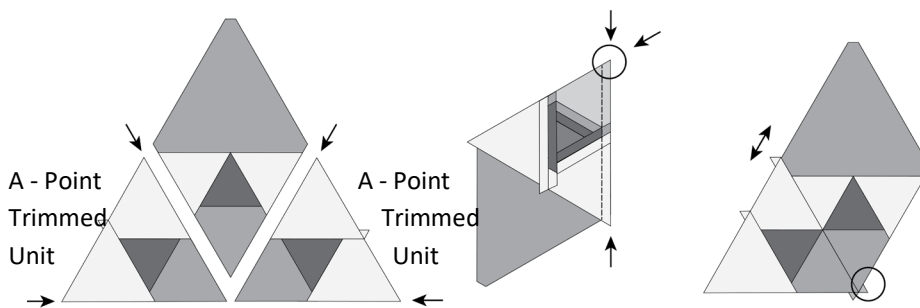

42. **Position and stitch** the three units as shown, make sure to place the two trimmed sides of A Unit towards the A Unit of the diamond shape and the bottom. Start by stitching the diamond shaped unit with the A Unit (L&R Point trimmed) which is on the left. Carefully **match the triangle seam intersections and align the raw edges of the trimmed triangle points**. **Stitch** with your best $\frac{1}{4}$ " seam allowance. Repeat for all units. **Press** the seams open and trim the dog ear of just the Light-Med of the diamond shape.

43. **Position and stitch** the remaining A Unit (L&R Point trimmed) onto the just sewn unit. Be careful to **match the triangle seam intersections and align the raw edges of the trimmed triangles**. **Note: Unit A's bottom point should align with the**

dog ear of the just sewn unit. **Stitch** with your best $\frac{1}{4}$ " seam allowance. Repeat for all units. **Press** the seams open and **trim** the dog ear. This is the Top Unit. Set aside for now.

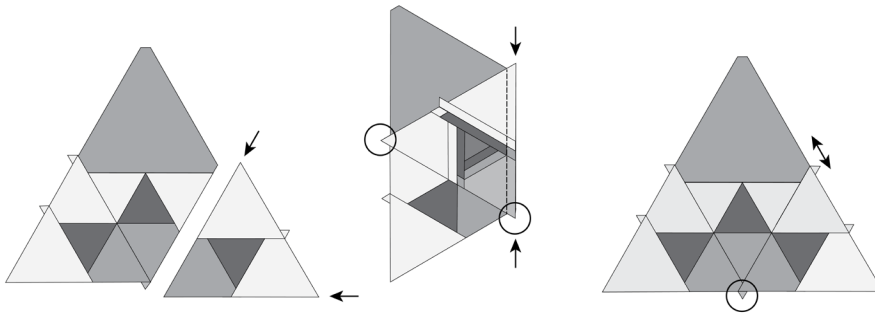

44. **Gather and position** the (12) B Units (Bottom trimmed). Divide the B Units into two stacks. Place (6) B Units with their bottom trimmed side toward the trimmed bottom of the remaining B Units.

45. **Position and stitch.** Flip the B Unit onto the B Unit, lining up the trimmed edges while centering the units. They should roughly be the same size. **Stitch** with your best $\frac{1}{4}$ " seam allowance. Repeat for all (6) units and **press** the seam open.

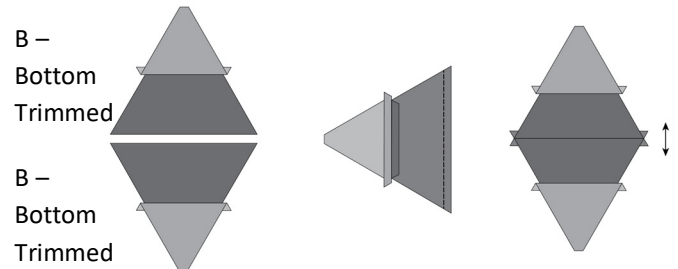

46. **Trim just one of the B Units** of each diamond shaped unit. Position the unit on the cutting mat so that for those that are right handed one of the B Units is in the 2 o'clock position or 10 o'clock if you are left handed. **Center the diamond shaped unit**, align the seam between the top B Unit's Triangle and Half Hexagon with the $1\frac{3}{4}$ " guideline, the seam between the B Units should line up with $3\frac{1}{4}$ " guideline, and the seam between the bottom B Unit's Triangle and Half Hexagon with the $4\frac{3}{4}$ " guideline. **Trim** both sides of the exposed B Unit. Repeat for each unit.

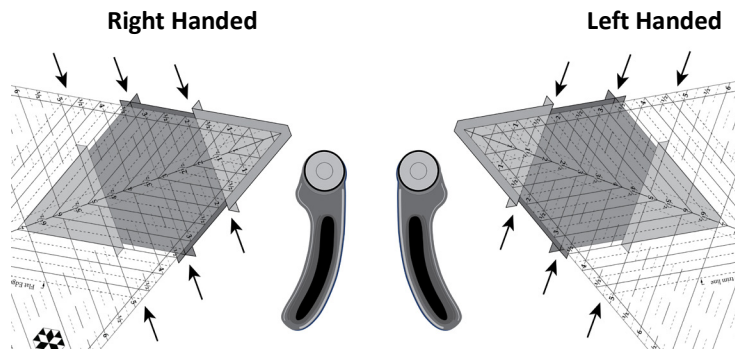

47. **Gather and position** the (3) C Units (L&R Point trimmed) with the (6) diamond shaped units created in step 46.

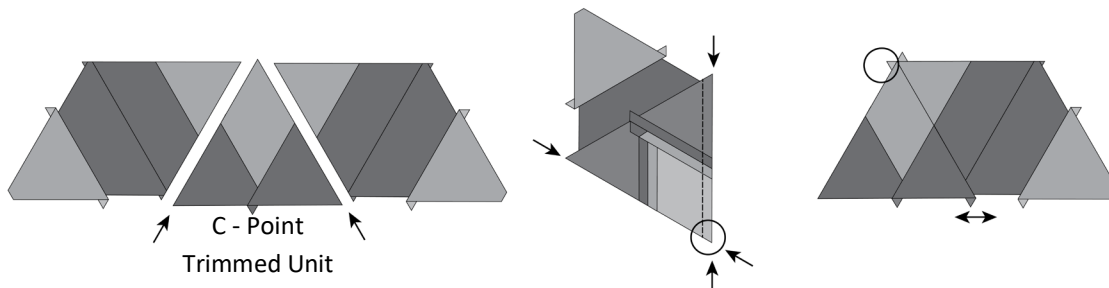

48. **Stitch the three units together** as shown. Start by stitching the diamond shaped unit on the right (from step 46) with the individual C Unit (Point Trimmed). Carefully **match the seam (recommend marking the $\frac{1}{4}$ " seam)** and align the raw edges of the trimmed triangle points. **Stitch** with the C Unit on top and your best $\frac{1}{4}$ " seam allowance. Repeat for all units. **Press** the seams open and **trim** the dog ear of the C Unit only.

49. **Position and stitch** the just sewn unit onto the remaining diamond shaped unit (from step 46). Be careful to **match the seam (recommend marking the 1/4" seam) and align the raw edges of the trimmed triangles**. **Stitch** with your best 1/4" seam allowance. Repeat for all units. **Press** the seams open and **trim** the dog ear. These are the Bottom Units.

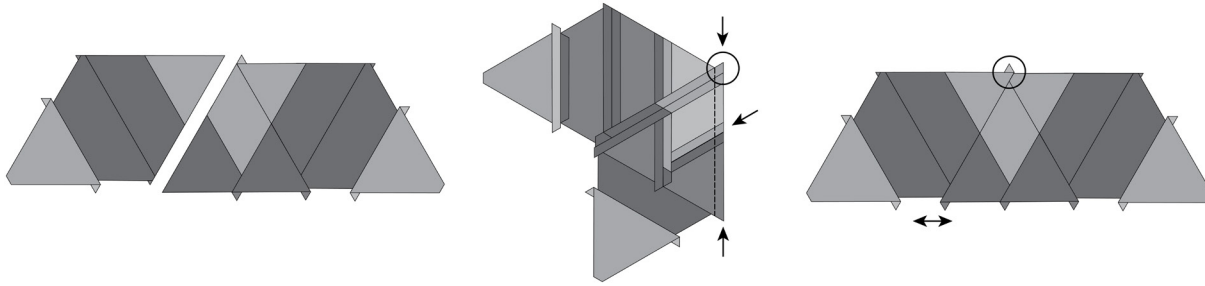

50. **Gather** the Top Units from step 43 and the Bottom Units that were just sewn.

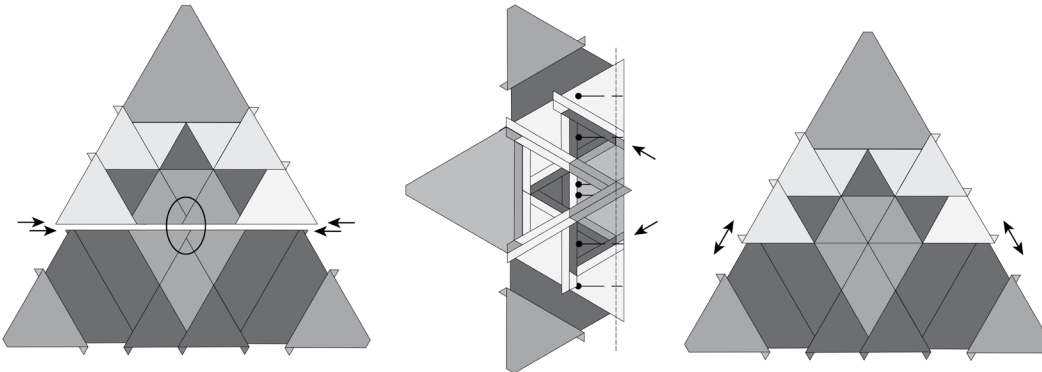

51. **Position and stitch**. Be careful to **align the points of the A Units and the center of Unit C of the bottom section, as well as the raw edges of the trimmed triangles**. **Stitch** with your best 1/4" seam allowance. Repeat for all units. **Press** the seams open.

52. **Trim the blocks**. Position the block on the cutting mat so that the top point is away from you and the bottom side near you. It helps to turn it slightly to 2 o'clock position if you are right handed and to 10 o'clock position if you are left handed. **Align the seam between the Companion Triangle and bottom of the A Unit with the 3 1/4" horizontal guideline, that same A Unit's bottom triangle should align with the 6" Diamond Point guidelines, and then the C Unit should align with the 9" Diamond Point guidelines of the block**. **Trim** both sides of the Block.

Right Handed

Left Handed

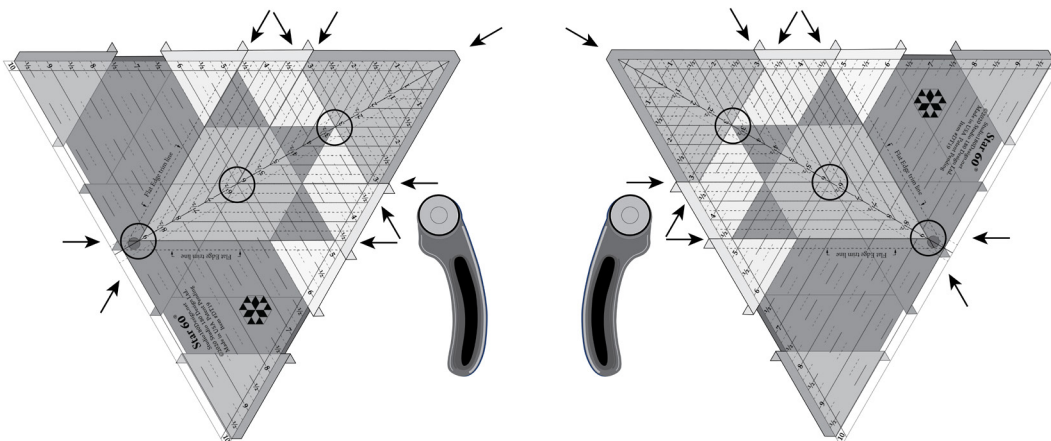

53. **Rotate** the block counter-clockwise for right handed, or clockwise for left handed exposing the untrimmed edge. For those that are right handed, line up the previously trimmed **edges of the block, one with the left edge of the Star 60 tool and the other with the 9 1/2" guideline**. For those that are left handed, line up the previously trimmed **edges of the block, one with the right edge of the Star 60 tool and the other with the 9 1/2" guideline**. Additionally, the 1 3/4" seam and the 6" and 9" Diamond guidelines will line up as well. **Trim** the remaining side. Repeat for each block.

Right Handed

Left Handed

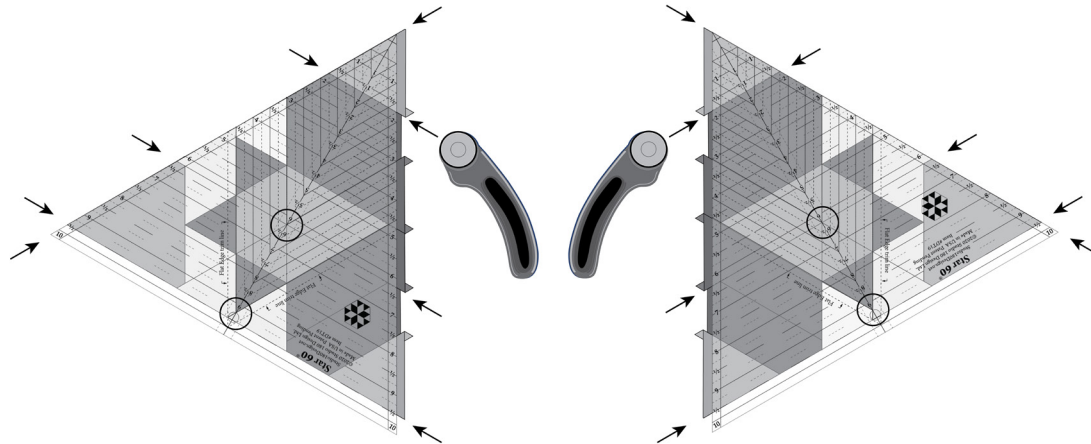

54. **Tada! You made it.** Be sure to post your photos in the [Best of the 60's Facebook Group](#).

ADDITIONAL WORK

55. **Label and set aside** as Block #20 will not be used in Group 8. However, **go onto the "Group 8" Construction Instructions.** Those instructions are available as a download in your Clue repository (Clue only members) or in your curriculum (Clue and Class members), filed below this Clue.
56. **Additionally, make (2) Billboard Blocks,** utilizing the **"Billboard Block" Instructions.** Those instructions are available as a download in your Clue repository (Clue only members) or in your curriculum (Clue and Class members), filed below this Clue.

IMPORTANT INSTRUCTIONS

- Place the Background Remnant Strips in your storage bag marked "Background scraps". You can use these strips for any block going forward that may require a strip of that same height. Do not cut them down to a different height.
- For each of the fat quarter remnant strips, keep these and place them in your storage bag marked "Fat Quarter scraps".
- Take the remainder of the fat quarters used in this clue, and also place these in your storage bag marked "Fat Quarter scraps".

CLUE #20 RECAP

- Song Trivia – *Oh, Pretty Woman*, 1964, Roy Orbison. *Oh, Pretty Woman* was recorded by Roy Orbison, written by Roy Orbison and Bill Dees. It was released as a single on August 29th, 1964 on Monument Records and spent three weeks at number one on the Billboard Hot 100. It was the second single by Roy Orbison to top the US charts. The record ultimately sold seven million copies and marked the high point in Orbison's career. At the year's end, Billboard ranked it the number four song of 1964. *Oh, Pretty Woman* was later used for the title of the 1990 film, *Pretty Woman*, starring Richard Gere and Julia Roberts.**
- [Link to Video](#)

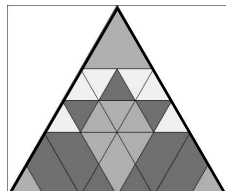
CLUE	BLOCK NAME	GRAYSCALE VERSION	UNIT CUT HEIGHT SIZE	UNIT FINISH HEIGHT SIZE	# OF BLOCKS
#20	OH, PRETTY WOMAN		9 1/2"	9"	3