 Teacher
Notes Series



GREEN HALL
Resource Center

Article # 286

Q Level

PHYSICS

Subject Code 5054

M. Arshad Chaudhry

**Read
Write**



GREEN HALL
Resource Center

Phone: 0325 524444

Contents

| | | |
|---------|--|-----|
| Unit-1 | MEASUREMENT | 8 |
| Unit-2 | KINEMATICS | 14 |
| Unit-3 | DYNAMICS | 20 |
| Unit-4 | MASS, WEIGHT AND DENSITY | 26 |
| Unit-5 | TURNING EFFECT OF FORCE | 30 |
| Unit-6 | WORK, POWER AND ENERGY | 34 |
| Unit-7 | PRESSURE | 40 |
| Unit-8 | KINETIC MODEL OF MATTER | 46 |
| Unit-9 | MEASUREMENT OF TEMPERATURE | 50 |
| Unit-10 | TRANSFER OF THERMAL ENERGY | 56 |
| Unit-11 | THERMAL PROPERTIES OF MATTER | 62 |
| Unit-12 | REFLECTION AND REFRACTION OF LIGHT | 68 |
| Unit-13 | LENSES AND DISPERSION OF LIGHT | 76 |
| Unit-14 | WAVES | 84 |
| Unit-15 | SOUND | 92 |
| Unit-16 | STATIC ELECTRICITY | 98 |
| Unit-17 | CURRENT ELECTRICITY AND D.C. CIRCUIT | 106 |
| Unit-18 | PRACTICAL ELECTRICITY | 112 |
| Unit-19 | MAGNETISM | 118 |
| Unit-20 | ELECTROMAGNETISM | 124 |
| Unit-21 | MAGNETIC FORCE | 130 |
| Unit-22 | ELECTROMAGNETIC INDUCTION | 136 |
| Unit-23 | ELECTRONS | 144 |
| Unit-24 | RADIOACTIVITY | 150 |

UNIT 1

Measurement

O Level Physics Teacher's Notes

M. A. Chaudhary
Cell: 0300-9412902

Syllabus 2017 – 18

Measurement

- Prefixes for SI Unit
- How to read Screw gauge
- Precautions of using calipers and Micrometer
- Errors in measurement
- Measurement of Time
- The Simple Pendulum
- Basic terms of Pendulum

UNIT-1 MEASUREMENT

PHYSICS is the science that deals with idea of matter and energy. The physical quantities are measured in units. There are seven SI base quantities in Physics. The names and their units are given below:

| Physical Quantities | Base Unit | Symbol |
|---------------------|-----------|--------|
| Length | metre | m |
| Mass | kilogram | kg |
| Time | second | s |
| Current | ampere | A |
| Temperature | kelvin | K |
| Amount of substance | mole | mol |
| Light Intensity | candela | cd |

PREFIXES FOR SI UNIT:

Prefixes are multiple and sub multiple units of Physical quantities. The prefixes are used to express the physical quantity in big or small values. Some commonly used SI prefixes are given below:

| Value | Prefix | Symbol |
|-----------|--------|--------|
| 10^{-1} | deci | d |
| 10^{-2} | centi | c |
| 10^{-3} | milli | m |
| 10^{-6} | mirco | μ |
| 10^{-9} | nano | n |
| 10^3 | Kilo | K |
| 10^6 | Mega | M |
| 10^9 | Giga | G |

The instruments for measurement of length

1: Metre Rule:-

- A metre rule is a wooden or plastic or steel bar of length 1m or 100 cm.
- The divisions marked on ruler are in cm, mm and inches.
- The accuracy or least count of ruler is 1mm or 0.1cm.
- The ruler is used to measure the length of straight objects or straight distance between two points in cm or in mm.
- The eye sight must be perpendicular to the point of reading of ruler to avoid parallax error.
- The wear and tear of instrument may damage few divisions at the ends of ruler. The error caused due to the damaged divisions is called zero error. Check the zero error before using the ruler.

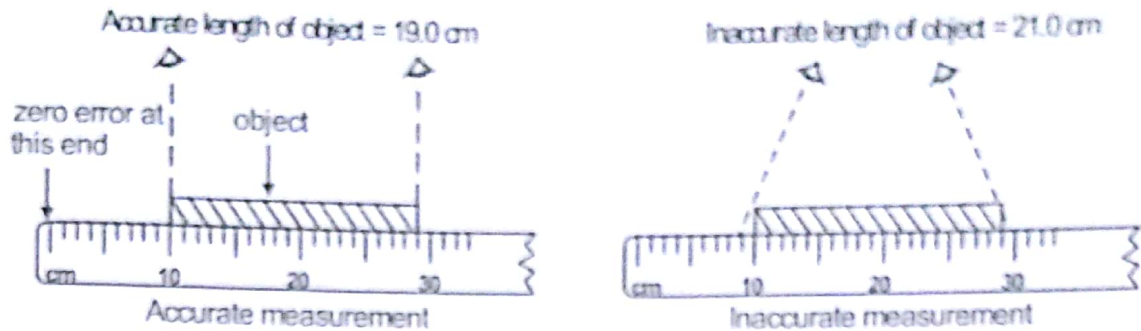

2: Measuring Tape:-

- A measuring tape is a plastic strip of several metres long.
- The divisions marked on tapes are in cm, mm, inches, feet and metres.
- The accuracy or least count of tape is 1mm or 0.1cm.
- The measuring tape is used to measure the distance between two points in meters. The tape can also measure the length or diameter or circumference of curved objects.
- The parallax error and zero error must be avoided while using measuring tape.

3: Vernier Callipers:-

- A vernier caliper consists of main scale, vernier scale and two jaws, made up of steel.
- The accuracy of this instrument is 0.1mm or 0.01cm.
- The vernier caliper is used to measure the diameter of spherical objects, internal and external diameter of tubes in cm or mm.

How to read Vernier calipers

- Check the zero error of instrument. Its value must be added to or subtracted from the final reading.
- Grip the object gently between outside jaws.

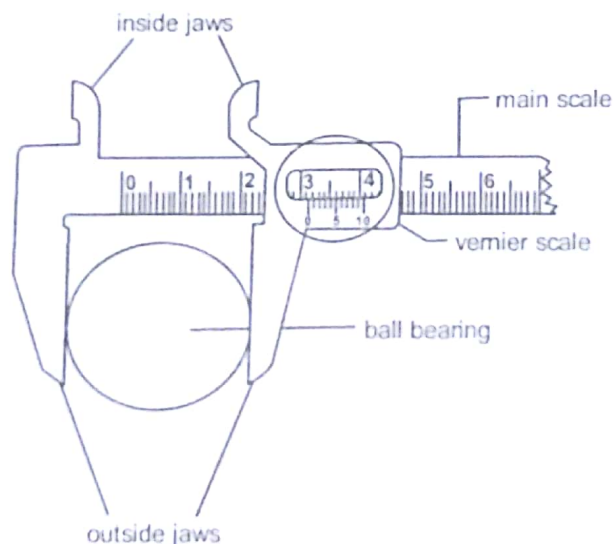

- Read the main scale division directly opposite the zero mark on the Vernier scale. For diagram above,

$$\text{Main scale reading} = 3.1 \text{ cm}$$

- Read the Vernier scale division which coincides with a marking on the main scale.
i.e. Vernier scale reading = $4 \times \text{L.C}$
= $4 \times 0.01 \text{ cm} = 0.04 \text{ cm}$

Final reading = main scale reading + vernier scale reading i.e.

$$\text{Final reading} = 3.1 + 0.04$$

Or

$$\text{Final reading} = 3.14 \text{ cm}$$

4: Micrometer Screw gauge:

- A screw gauge consists of ratchet, thimble, sleeve, spindle and anvil.
- The accuracy of this instrument is 0.01 mm or 0.001cm
- The screw gauge is used to measure diameter of ball bearings & wires, thickness of coin & paper etc.

HOW TO READ SCREW GAUGE

- Check the zero error, by closing the spindle without any object. This value is either added to or subtracted from the final reading.
- Grip the object between anvil and spindle. The ratchet is used to tighten the object in the grip.

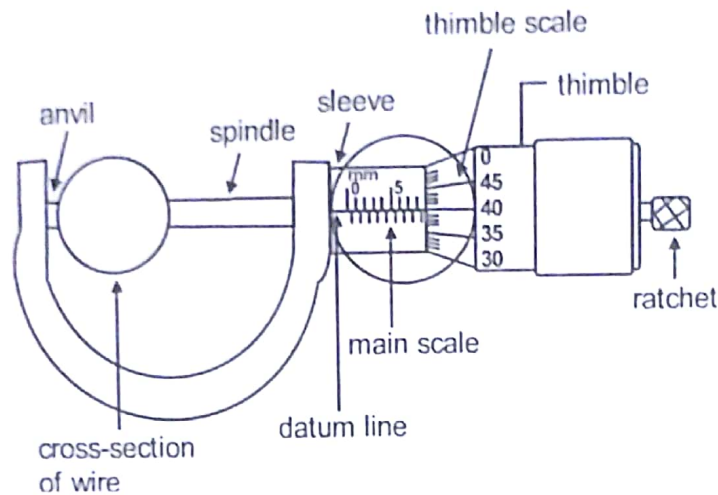

- Read the main scale, by noting the last division seen on the sleeve.
For diagram above:
Main scale reading = 8.5 mm
- Read the thimble scale division, coinciding with the datum line.
i.e. Thimble scale reading = $40 \times \text{L.C}$
 $= 40 \times 0.01 = 0.40 \text{ mm}$
The final reading can be calculated as:
- Final reading = main scale reading + thimble scale reading
Final reading = $8.5 + 0.40$
i.e. Final reading = 8.90 mm

PRECAUTIONS OF USING CALIPERS AND MICROMETER:

- Check zero error and note its value.
- Clean and wipe the instruments.
- Avoid parallax error.
- Grip the object in instruments gently.
- Repeat the reading and take average value for more accuracy.

ERRORS IN MEASUREMENT:

- Parallax error:**
This error is produced due to wrong positioning of eye level on the point of reading. The eye sight must be perpendicular to the point of reading to avoid this error.
- Zero error:**
The zero error occurs when the vernier caliper or micrometer is fully closed without any object and does not give zero reading.
The zero error is either added to or subtracted from the final reading.

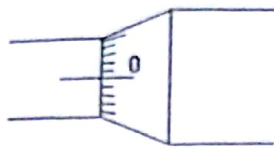

No zero error

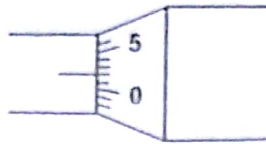

All measurements should be reduced by 0.03 mm (- 0.03 mm)

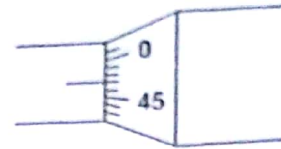

All measurements should be increased by 0.03mm (+0.03 mm)

3. **Human Reaction error:**

The error caused by a person in noting the time intervals, due to his/her reaction time. This error varies from person to person according to their age. This error can be minimized by repeating the experiment and taking average values.

MEASUREMENT OF TIME:

Time is measured in years, months, days, hours, minutes and seconds. Due to wide range of time intervals different kinds of clocks and watches are used as summarized in the table below.

| Type of clock/watch | Use and accuracy |
|-------------------------|---|
| Atomic Clock | Measure very short time intervals of about 10^{-10} seconds. |
| Digital stopwatch | Measure short time interval (in minutes and seconds) to an accuracy of $\pm 0.01s$ |
| Analogue stopwatch | Measures short time intervals (in minutes and seconds) to an accuracy of $\pm 0.1s$. |
| Ticker-tape timer | Measures short time intervals of 0.02 s. |
| Watch | Measures longer time intervals in hours, minutes and seconds. |
| Pendulum clock | Measures longer time intervals in hours, minutes and seconds. |
| Radioactive decay clock | Measures in years the age of remains from thousands of years ago |

THE SIMPLE PENDULUM:

A simple pendulum consists of a metal bob, attached at the end of string, hanging from a support.

BASIC TERMS OF PENDULUM:

- **Oscillation:**
One complete round trip of a pendulum is called oscillation. i.e. from $O \rightarrow A \rightarrow B$ and back to O .
- **Time Period (T):**
Time taken by a pendulum to complete one oscillation.
- **Frequency (f):**
It is number of oscillations completed in one second.

where f = frequency, measured in Hertz (Hz).

$$f = \frac{1}{T}$$

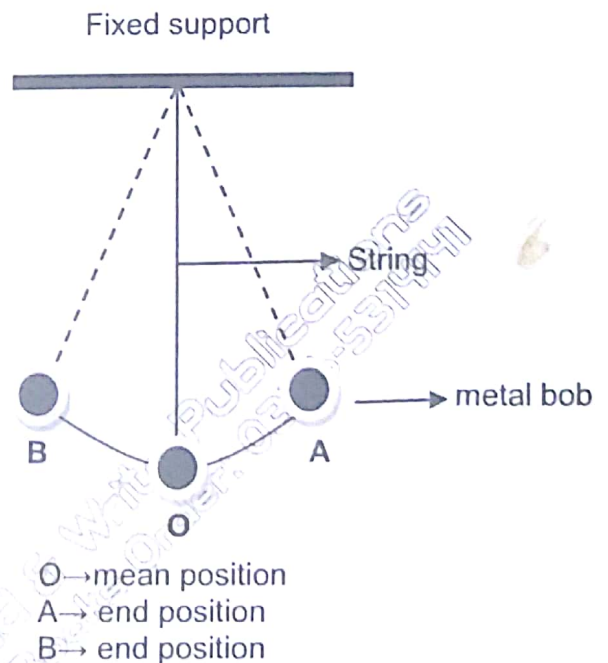

How to determine time period of a Pendulum using stop watch?

- Set the pendulum into motion.

- Note time for 20 oscillations by using stopwatch.
- Find the time for one oscillation by using the formula:

$$T = \frac{t}{n}$$

Where

t = time noted by watch.

n = no. of oscillations.

T = time period.

M. Arshad Ch.
0300-9412902

UNIT 2

Kinematics

O Level Physics Teacher's Notes

M. A. Chaudhary
Cell: 0300-9412902

Syllabus 2017 – 18

Kinematics

- Basic Definitions
- Retardation or Deceleration
- Key points of using Kinematics formulae
- Key points of Distance-Time graph
- Calculation from Distance-Time Graph
- Calculations from Speed-Time graph

Unit-2 KINEMATICS

BASIC DEFINITIONS:

Displacement:-

The shortest and straight line distance between two points, travelled in a specific direction.

Unit: m

Speed:- Distance travelled per unit time.

Formula:
$$\text{Speed} = \frac{\text{distance}}{\text{time}}$$

Unit: m/s or ms^{-1}

Types of Speed:

a) Average Speed:

It is the total distance travelled in total time.

Formula:

$$\text{Average Speed} = \frac{\text{Total distance}}{\text{Total time}}$$

Or $\langle V \rangle = \frac{u+v}{2}$

Where u = initial speed.

V = final speed.

$\langle V \rangle$ = average speed.

b) Uniform Speed:

If the object is moving with constant speed, then its speed is uniform.

c) Non-Uniform speed:

if the speed of an object changes with time, then it is moving with non-uniform or variable speed.

Acceleration:

It is increase in velocity per unit time.

Formula:

$$\text{Acceleration} = \frac{\text{change in velocity}}{\text{time}}$$

$$a = \frac{v-u}{t}$$

Where u = initial velocity.

t = time taken.

a = acceleration.

Unit: m/s^2 or ms^{-2}

RETARDATION OR DECELERATION:

It is decrease in velocity per unit time.

M. Arshad Ch.
0300-9412902

Types of acceleration:**a) Uniform acceleration:**

If velocity of an object changes in equal amounts in equal time intervals, then acceleration is uniform.

b) Non-Uniform acceleration:

If velocity of an object changes unequally in equal time intervals, then acceleration is non-uniform.

Formulae in Kinematics

1. $\langle V \rangle = \frac{u+v}{2}$ or $\frac{\text{total distance}}{\text{total time}}$
2. $a = \frac{v-u}{t}$
3. Distance = average speed \times time
i.e. $S = \left(\frac{u+v}{2}\right)t$

Where u = initial speed.

V = final speed.

$\langle v \rangle$ = average speed.

t = time.

a = acceleration.

S = distance.

KEY POINTS OF USING KINEMATICS FORMULAE:

- If a body starts from rest, then initial speed $u = 0$
- If a moving body comes to rest, then final speed $v = 0$
- If a body is thrown upwards, at highest point, final speed $v = 0$
- If a body falls freely, at starting point, initial speed $u = 0$
- Time taken to reach max. height = Time taken to return to original position.

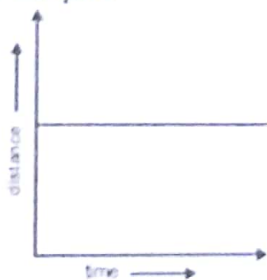
Distance-Time Graphs

A horizontal line indicates a speed zero, as the body is not moving from its initial position.

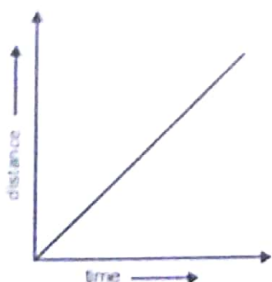

A straight line shows uniform speed since distance increases uniformly with time.

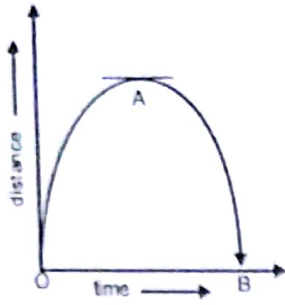

The distance-time curve is that of non-uniform speed. From O→A, speed decreases gradually to zero, from A→B, speed increases.

KEY POINTS OF DISTANCE-TIME GRAPH:-

- The gradient of distance-time graph is the speed of a body.
- If gradient is zero, body is at rest.
- If gradient is constant, body is moving with uniform speed.
- If gradient varies, body is moving with non-uniform or variable speed.
- If gradient is negative, body is moving in opposite or reverse direction.

CALCULATION FROM DISTANCE-TIME GRAPH:

1. Speed = gradient of line

i.e.
$$\text{Speed} = \frac{\text{change in distance}}{\text{time taken}}$$

2. Average speed =
$$\frac{\text{total distance}}{\text{total time}}$$

Speed-Time Graphs

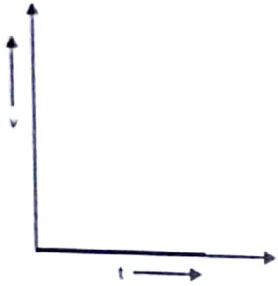

Object is at rest.

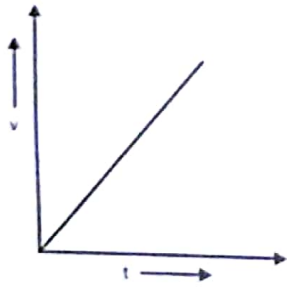

Speed of object is increasing uniformly with constant acceleration

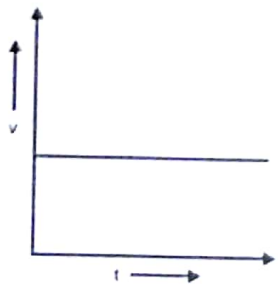

Speed of object is constant so acceleration is zero.

M. Arshad Ch.
0300-9412902



Speed of object is decreasing uniformly, with constant retardation.

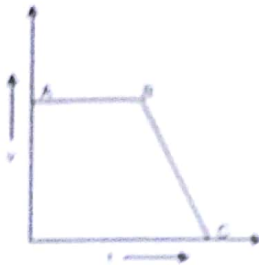

- From A→B, speed is constant with zero acceleration.
- From B→C, speed decreases uniformly with constant retardation.

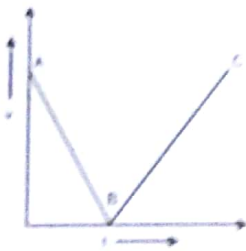

- From A→B, speed is decreasing uniformly with constant retardation.
- At B, object is at rest.
- From B→C speed is increasing uniformly with constant acceleration.

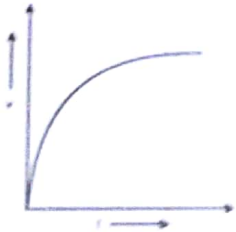

- The acceleration decreases gradually, because rate of change of speed is decreasing with time.

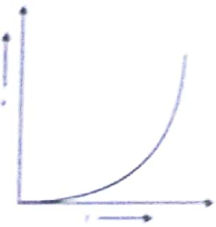

- The acceleration increases gradually because rate of change of speed is increasing with time.

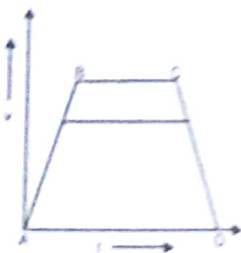

- A→B, acceleration is uniform.
- B→C, acceleration is zero.
- C→D, retardation is uniform.

Revision Notes Publications
 For Examinations and Assignments
 Contact: 031-35094781, 35094782, 35094783

CALCULATIONS FROM SPEED-TIME GRAPH:

1) Acceleration = $\frac{v-u}{t}$ = gradient of line.

2) Distance = Area under a speed time graph.

Area of a triangle = $\frac{1}{2}$ base \times height.

Area of rectangle = length \times breadth.

Area of a trapezium = $\frac{1}{2}$ (sum of parallel sides) height.

i.e. $\frac{1}{2}(a+b)h$.

where a = length of one side.

b = length of other side

h = height between a and b.

Acceleration of free fall or acceleration due to gravity

The uniform acceleration produced to the freely falling body, due to gravity is called acceleration of free fall. Its value is approximately 10ms^{-2} .

- > The acceleration due to gravity is directed towards centre of the earth.
- > The acceleration due to gravity does not depend on masses of the falling bodies.
- > In the presence of air resistance, the acceleration due to gravity decreases.
- > For upward motion, the acceleration due to gravity is $g = -10\text{ms}^{-2}$ and for downward motion, $g = +10\text{ms}^{-2}$.

Motion of bodies in air resistance

The air resistance has the following effects:

1. It always opposes the motion of moving objects.
2. It increases with the increase of speed of the objects.
3. It increases with the size of the object.

Terminal velocity:-

When the air resistance on an object falling in gravitational field becomes equal to the force of gravity, then object moves with uniform velocity, called as terminal velocity.

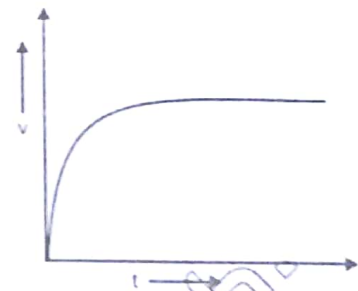

Graph of terminal velocity

Graph Shows that:

- Object falls with an initial acceleration of 10ms^{-2} i.e. with acceleration of gravity.
- The acceleration gradually decreases.
- When air resistance and gravity forces become equal then acceleration is zero.

UNIT 3

Dynamics

O Level **Physics Teacher's Notes**

M. A. Chaudhary
Cell: 0300-9412902

Syllabus 2017 – 18

Dynamics

- Forces
- Effect of Force
- Types of Forces
- Effects of friction on the motion of a vehicle
- Braking, thinking & stopping distances
- Examples of circular motion
- Balanced and Unbalanced Forces
- Newton's law of motion
- Methods to determine resultant vector
- Deformation
- Arrangement & Procedure

Unit-3 DYNAMICS

SECTION-1 = FORCES

Force: It is pull or push on an object that changes or tends to change the state of rest or uniform motion of that object.

EFFECT OF FORCE:

- Force can change the shape of a body.
- Force can stop the moving body.
- Force can set the body into motion.
- Force can accelerate the body.
- Force can decelerate the body.
- Force can change the direction of a moving body.

TYPES OF FORCES:

| Forces | Description |
|---|---|
| 1. Force of Gravity | The pull of earth acting on an object. |
| 2. Force of gravitation | It is force of attraction between any two objects in the universe. |
| 3. Tension | It is the force experienced by stretched or compressed objects. |
| 4. Friction | The contact force which opposes the motion of body, due to the roughness of surface. |
| 5. Resistance | When a body is dragged through a fluid (air or liquid), there is a friction between body and fluid called as resistance or viscous force. |
| 6. Contact Force or Normal reaction Force | When an object is made in contact with a surface, then the reaction force of that surface is called contact force or normal reaction force. |
| 7. Electric Force | The push or pull between electric charges. |
| 8. Magnetic Force | The push or pull between magnets. |

Effects of Friction:

Friction is a contact force that slows down moving objects. Friction has both positive and negative effects.

Negative Effects

1. Force of friction causes wear and tear in moving parts of machine.
2. Force of Friction reduces the engine power.

Positive Effects

1. Force of friction helps in holding the objects, walking on ground.
2. Force of friction helps in stopping the moving vehicles.

Methods of Reducing Friction

1. Using highly polished surface for moving parts.
2. Using a layer of lubricants between moving parts.
3. Using ball bearings to enable surface to roll over.
4. Making the aerodynamic shapes of moving objects.

Unit-3 DYNAMICS

SECTION-1 = FORCES

Force: It is pull or push on an object that changes or tends to change the state of rest or uniform motion of that object.

EFFECT OF FORCE:

- Force can change the shape of a body.
- Force can stop the moving body.
- Force can set the body into motion.
- Force can accelerate the body.
- Force can decelerate the body.
- Force can change the direction of a moving body.

TYPES OF FORCES:

| Forces | Description |
|---|---|
| 1. Force of Gravity | The pull of earth acting on an object. |
| 2. Force of gravitation | It is force of attraction between any two objects in the universe. |
| 3. Tension | It is the force experienced by stretched or compressed objects. |
| 4. Friction | The contact force which opposes the motion of body, due to the roughness of surface. |
| 5. Resistance | When a body is dragged through a fluid (air or liquid), there is a friction between body and fluid called as resistance or viscous force. |
| 6. Contact Force or Normal reaction Force | When an object is made in contact with a surface, then the reaction force of that surface is called contact force or normal reaction force. |
| 7. Electric Force | The push or pull between electric charges. |
| 8. Magnetic Force | The push or pull between magnets. |

Effects of Friction:

Friction is a contact force that slows down moving objects. Friction has both positive and negative effects.

Negative Effects

1. Force of friction causes wear and tear in moving parts of machine.
2. Force of Friction reduces the engine power.

Positive Effects

1. Force of friction helps in holding the object walking on ground.
2. Force of friction helps in stopping the moving vehicles.

Methods of Reducing Friction

1. Using highly polished surface for moving parts.
2. Using a layer of lubricants between moving parts.
3. Using ball bearings to enable surface to roll over.
4. Making the aerodynamic shapes of moving objects.

EFFECTS OF FRICTION ON THE MOTION OF A VEHICLE

1. **Tyre surface:** If tyre surface is in good condition then there is more friction between the tyre and the road. The moving vehicle can be stopped easily within the stopping distance.
2. **Road Condition:** If road is wet, the friction between tyres and road reduces, resulting in increase to the stopping distance. The vehicles can also skid at turns, due to wetness of road.
3. **Braking Force:** If braking pads/discs are in good condition, then braking force causes more friction and stopping distance reduces.

BRAKING, THINKING & STOPPING DISTANCES

1. **Braking distance:** The distance travelled by a moving vehicle during the time that the brakes are applied.
2. **Thinking distance:** The distance travelled by moving vehicle during the reaction time of driver, before applying the brakes.
3. **Stopping distance:** The total distance travelled by moving vehicle, between thinking the distance and stopping the vehicle. i.e.
 Stopping distance = thinking distance + braking distance.
 The braking, thinking and stopping distances are not equal due to following factors.
 - a) The road condition.
 - b) The tyres condition.
 - c) The brakes condition.
 - d) The speed of moving vehicle.
 - e) The vehicle is loaded or unloaded.
 - f) The human reaction of driver.

Circular motion

If the distance of an object remains constant from a fixed point, throughout its motion, then object is in circular motion. The circular motion has following characteristics.

- If speed of object in circle is constant, its direction keeps on changing, so velocity is not constant.
- The direction of velocity at any instant in circular motion is determined by the tangent to circle at that point.
- The force which keeps the object moving in circular path is called centripetal force. This force is always directed towards centre of circle.

EXAMPLES OF CIRCULAR MOTION:

1. **Motion of electrons:**
 The electrostatic force exerted by the nucleus on electron, provides centripetal force to electrons. The electrons keep on orbiting around the nucleus in circular motion.
2. **Motion of Satellite:**
 The force of gravity of earth provides centripetal force to the satellite. The satellite keeps on orbiting around the earth in circular motion.
3. **Motion of Planets:**
 The planets move around the sun due to gravitational force. The gravitational force provides centripetal force to the planets. Each planet in the solar system is directed towards sun, due to centripetal force and keeps on moving in fixed orbit.

BALANCED AND UNBALANCED FORCES:

Balanced Forces: Two equal forces acting in opposite directions cancel each other out. These forces are balanced forces. The balanced forces produce two effects.

1. Object is either at rest or
2. Moving at a steady speed.

Unbalanced Forces: Two forces of different values acting in opposite directions, on an object are unbalanced forces.

The unbalanced forces

1. Either accelerate the object or
2. Decelerate the object

NEWTON'S LAW OF MOTION:

First Law: A body continues its state of rest or uniform motion until an external force acts on it.

Second Law: When a force acts on a body, then acceleration is produced such that

- $a \propto F$ i.e. acceleration directly proportional to the force applied.
- $a \propto 1/m$ i.e. acceleration inversely proportional to the mass of body.

The acceleration, force and mass are related by the formula:

$$F = ma$$

The unit of force is **Newton (N)**.

Third Law: To every action there is equal and opposite reaction.

Scalar and Vector

1. A scalar quantity is that which has magnitude only.
2. A vector quantity has magnitude as well as direction.

Examples:

| Quantity | Scalar | Vector |
|--------------|--------|--------|
| Distance | ✓ | |
| Displacement | | ✓ |
| Length | ✓ | |
| Speed | ✓ | |
| Velocity | | ✓ |
| Time | ✓ | |
| Acceleration | | ✓ |
| Force | | ✓ |
| Weight | | ✓ |
| Density | ✓ | |
| Area | ✓ | |
| Volume | ✓ | |
| Energy | ✓ | |
| Pressure | | ✓ |

Resultant Vector: The combined effect of two vectors is called resultant vector.

METHODS TO DETERMINE RESULTANT VECTOR:

1. **By addition:** If two vectors are in the same direction then their magnitudes are added up to find resultant vector.
2. **By Subtraction:** If two vectors are in opposite direction, then they are subtracted from each other to find resultant vector.
3. **Parallelogram method:** If two vectors are at certain angle, then Parallelogram method is used to find resultant vector. "Complete the parallelogram joining the given vectors at their angle. The length of diagonal determines the resultant vector."

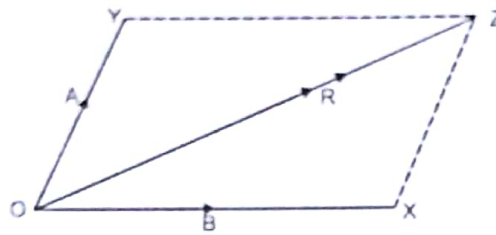
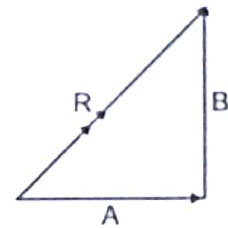

Fig. Parallelogram
A & B → vectors
R → resultant vector.

4. **Triangle method:** If two vectors are at 90° , then the resultant vector is obtained by head to tail rule. "Join the head of first vector with the tail of second vector. The resultant vector is obtained by joining the tail with the tail of first vector and head with the head of second vector."



A & B → vectors
R → resultant vector.

SECTION -3=DEFORMATION

Elasticity or Elastic deformation:

When a force is applied then shape of an object can be changed. On releasing the force if object regains its original shape then this effect is called elasticity or elastic deformation.

Elastic limit or limit of proportionality:

It is the maximum extension in an elastic object, after which it either breaks or deforms permanently.

Hooke's Law:

Within elastic limit, the extension produced in an elastic object is directly proportional to the force applied.

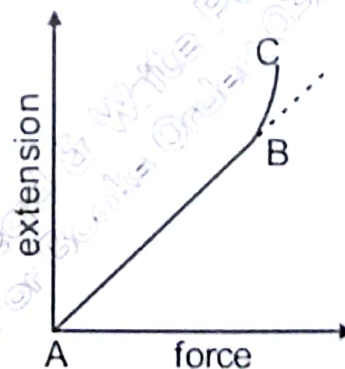
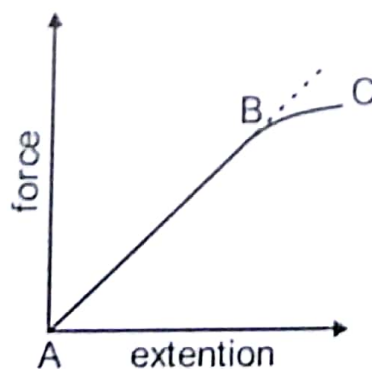

Point A = Hooke's law is valid.

Point B = Elastic limit or limit of proportionality.

Point C = Breaking point.

A to B = elastic deformation.

B to C = Plastic deformation.

Experiment to verify Hooke's law.

Apparatus: Spring, metre rule, stand, weights or loads.

ARRANGEMENT & PROCEDURE:

- Attach a spring with stand and measure its original length (l_1) with rule.
- Attach a load or weight at the end of spring. Measure stretched length of spring (l_2) with rule.
- Similarly, attach different loads at the end of spring and measure the stretched lengths of spring for each load.
- Record the results in the table

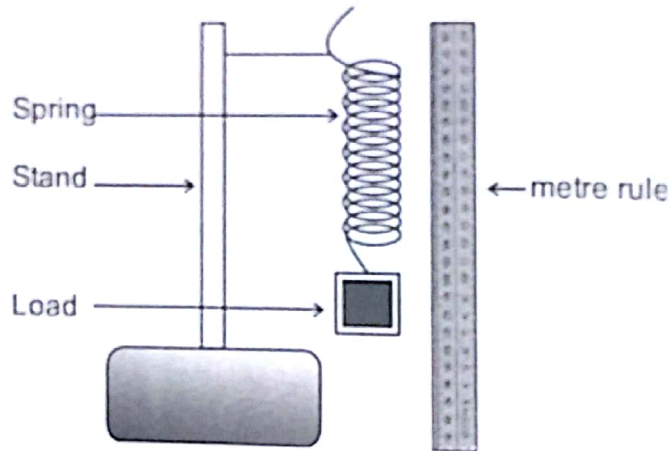

| No. of Obs. | Original length (l_1) Cm | Final length (l_2) Cm | Extension ($l_2 - l_1$) Cm | Load/weight N |
|-------------|---------------------------------|------------------------------|---------------------------------|------------------|
| 1 | | | | |
| 2 | | | | |
| 3 | | | | |
| 4 | | | | |
| 5 | | | | |

- Draw the graph between extension and load, the graph is a straight line passing through origin. So Hooke's law is verified.

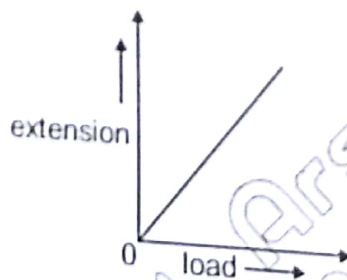

UNIT 4

**Mass, Weight
And Density**

**O Level
Physics Teacher's Notes**

**M. A. Chaudhary
Cell: 0300-9412902**

Syllabus 2017 – 18**Mass, Weight and Density**

- Gravitational Field
- Gravitational Field Strength
- Procedure
- To determine density of Regular object
- To determine density of irregular object

Unit-4 MASS, WEIGHT AND DENSITY

GRAVITATIONAL FIELD:

Gravitational field is a region in which a mass experiences a force due to gravitational attraction.

GRAVITATIONAL FIELD STRENGTH:

It is the gravitational force acting per unit mass. Its value is approximately 10 Nkg^{-1} i.e. force of gravity acting on an object of mass 1kg is about 10N , on the Earth's surface.

Difference between Mass and Weight:

| Mass | Weight |
|--|---|
| 1. The amount of substance in a body is called mass. | 1. The pull of gravity on a body is called weight. |
| 2. The mass remains constant everywhere. | 2. The weight of a body varies from place to place. |
| 3. Mass has no direction i.e. scalar quantity. | 3. The weight is directed towards centre of earth i.e. vector quantity. |
| 4. It is measured in Kg. | 4. It is measured in N. |
| 5. It is measured by beam balance or electronic balance. | 5. It is measured by spring balance or Newton meter. |

Calculation of Weight:

The mass and weight are related by the formula:

$$W = mg$$

Where m = mass of object

W = weight of object

g = gravitational field strength or acceleration to gravity. The value of g is 10Nkg^{-1} or 10ms^{-2} .

Inertia:

It is the ability of a body to resist when its state of rest or uniform motion tends to be changed.

The inertia depends on mass of a body. The massive bodies offer more resistance, when their state of rest or motion is changed i.e. they have higher inertial values than lighter bodies.

Examples:-

1. When the car travelling straight turns round the corner, the passengers tend to fall in opposite direction of turn, due to inertia.
2. A person riding on motorcycle, if suddenly brakes are applied, tends to fall forward due to inertia.

Density:

The mass per unit volume of a substance is called density.

Formula: $\text{Density} = \frac{\text{mass}}{\text{volume}}$

Or $\rho = \frac{m}{v}$

Unit: Kgm^{-3} or gcm^{-3}

Methods to determine density of a

- a) Liquid.

- b) Regularly shaped object.
- c) Irregularly shaped object.

To determine density of Liquid:

Apparatus: beam balance, burette, beaker and stand.

PROCEDURE:

1. Find the mass (m_1) of an empty beaker with beam balance.
2. Shift a known volume (V) of the liquid from burette into beaker.
3. Find the mass (m_2) of beaker and the liquid with beam balance.

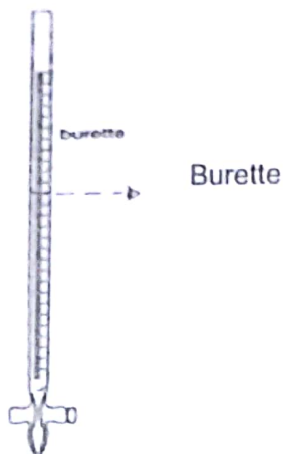

Calculation:

The mass of liquid = $m = m_2 - m_1$

Use the formula:

$$\text{Density} = \frac{\text{mass}}{\text{volume}}$$

to find density of given liquid.

TO DETERMINE DENSITY OF REGULAR OBJECT:

Apparatus: beam balance, ruler, regular shaped object

Procedure:

1. Determine the mass of regular object with beam balance.
2. Measure the length (l), breadth (b) and height (h) by using a meter rule.

Calculation:

The volume of object = $l \times b \times h$

Use the formula,

$$\text{Density} = \frac{\text{mass}}{\text{volume}}$$



to find density of regular object.

TO DETERMINE DENSITY OF IRREGULAR OBJECT:

Apparatus: Beam balance, measuring cylinder, irregularly shaped object.

Procedure:

1. Find the mass of irregular object with Beam balance.
2. Fill measuring cylinder with water up to volume (V_1)
3. Completely immerse the object into water. Find the new volume (V_2).

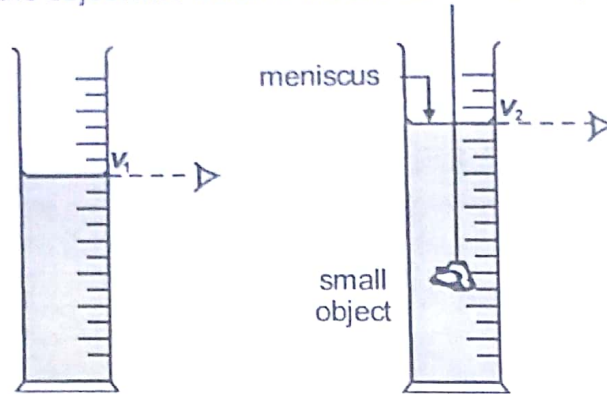

Calculation:

The volume of irregular object = $V_2 - V_1$

Use the formula: $\text{density} = \frac{\text{mass}}{\text{volume}}$

to determine density of irregularly shaped object.

Precautions:

- Avoid parallax error.
- Place the measuring cylinder on a flat surface.
- Read the volume from bottom of meniscus.
- The object must be completely immersed into liquid.
- Measure mass of object, before measuring its volume.

Note:

- If object floats in water, then tie a sinker to object. Subtract the volume of the sinker from the final reading.
- If the object is too big to be lowered into the measuring cylinder, use a displacement can to determine volume of solid.

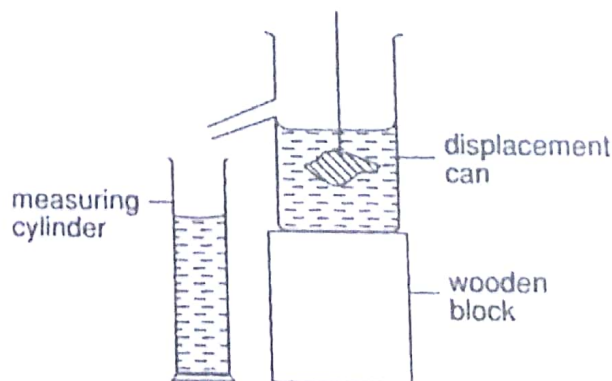

UNIT 5

Turning Effect Of Force

**O Level
Physics Teacher's Notes**

**M. A. Chaudhary
Cell: 0300-9412902**

Syllabus 2017 – 18

Turning Effect of Force

- Turning Effect
- Moment of Force
- Equilibrium
- Centre of mass (c.m) or Centre of gravity (c.g)

Unit-5 TURNING EFFECT OF FORCE

TURNING EFFECT:

When a force is applied then object may turn round a fixed point. This is called turning effect of force. The point around which object turns is called pivot or hinge or fulcrum.

The turning effect depends on

- Magnitude of force (F) applied.
- The perpendicular distance (d) from the line of action of force to the pivot.

Examples of Turning Effect:

- Opening of a hinged door.
- Paddling of a bicycle.
- Opening of a bottle cap.
- Turning the steering wheel.

MOMENT OF FORCE:

"It is the product of force and perpendicular distance from the line of action of the force to the pivot."

Formula:

$$\text{Moment of Force} = F \times d$$

Where F = Magnitude of Force.
 d = perpendicular distance.

Unit: Nm.

Clockwise and Anticlockwise Moments:

- > If the object turns clockwise, then turning effect is called clockwise moments.
- > If object turns anticlockwise, then turning effect is called anticlockwise moments.

EQUILIBRIUM:

"A body at rest or moving with uniform velocity is said to be in equilibrium."

The two conditions of equilibrium are:

- Sum of forces in one direction is equal to sum of forces in other direction.
- Sum of clockwise moments is equal to sum of anticlockwise moments.

Principle of moments:

For an object in equilibrium, the sum of clockwise moments is equal to sum of anticlockwise moments. i.e. Clockwise moments = Anticlockwise moments

i.e. $F_1 \times d_1 = F_2 \times d_2$

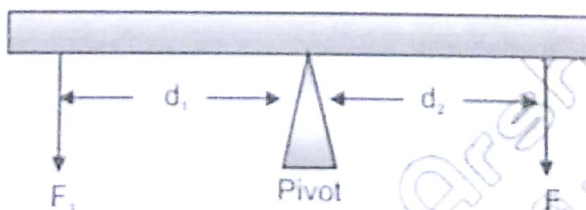

Experiment: To investigate the Principle of Moments

Apparatus: Uniform metre rule, load (W_1), load (W_2), strings, knife edge, Retort stand.

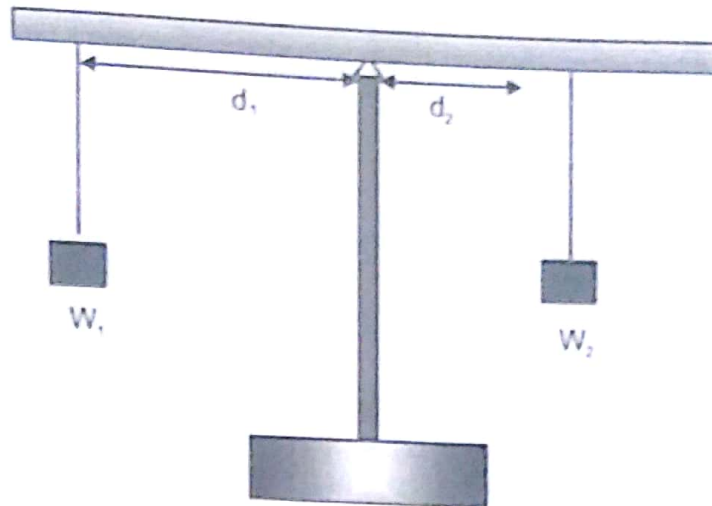

Procedure:

- 1) Set up the apparatus as shown in Figure with the knife edge at the 50 cm mark.
- 2) Balance the system by adjusting the distances d_1 and d_2 .
- 3) Vary d_1 and change d_2 so that the system is balanced for 5 sets of d_1 and d_2 .
- 4) Calculate the anticlockwise moments $W_1 \times d_1$ and the clockwise moments $W_2 \times d_2$ and tabulate as follows:

Table:

| W_1 | d_1 | W_2 | d_2 | $W_1 \times d_1$ | $W_2 \times d_2$ |
|-------|-------|-------|-------|------------------|------------------|
| | | | | | |

Observation:

From the table, the anticlockwise moments given by $(W_1 \times d_1)$ are found to be equal to the clockwise moments given by $(W_2 \times d_2)$ for each set of d_1 and d_2 . So principle of moments is verified.

CENTRE OF MASS (C.M) OR CENTRE OF GRAVITY (C.G)

The point through which whole mass or weight of an object appears to act is called its centre of mass (c.m) or centre of gravity (c.g).

To locate c.g. of regular objects:

The c.g of regular objects can be determined by balancing them on a knife edge or pivot. The c.g. of some regular objects are described below with diagrams.

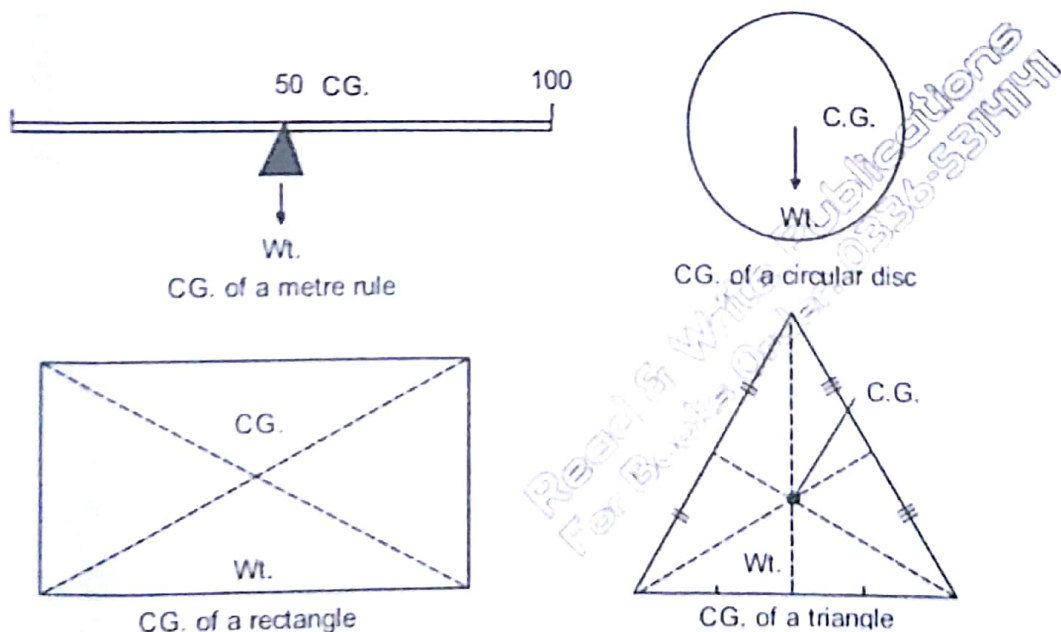

To determine position of c.m or c.g of plane lamina of irregular shape by plumb line.

Apparatus: Irregular lamina, Stand, Plumb line, Cork and Pin.

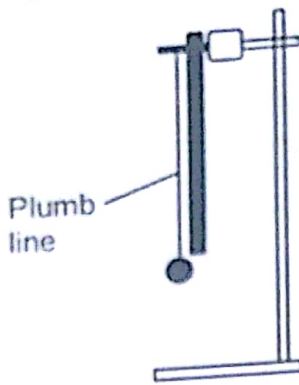

Fig. Plumb line

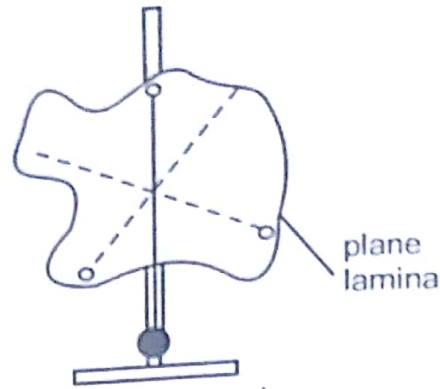

Fig. Irregular Lamina

1. Make three small holes near the edges of the lamina.
2. Suspend the lamina through one of the holes using a pin.
3. Hang a plumb line on the pin in front of the lamina.
4. When the plumb line is steady, draw a line on the lamina along the plumb line.
5. Repeat the above procedure for the remaining two holes.
6. The point of intersection of the three lines on the lamina is the position of centre of mass or centre of gravity.

Precautions:

1. The lamina should be free to swing about its point of suspension.
2. The parallax error must be avoided.

Stability of Objects:

"The ability an object to regain its original position after it has been tilted slightly" determines the stability of that object.

The stability of an object depends on:

a) Base area of object:

The area of the base of an object should be as wide as possible, for more stability.
e.g. the household objects like desk lamps have wide and heavy bases for more stability.

b) The position of c.m or c.g:

The centre of gravity (c.g) of an object should be as low as possible, for more stability.
e.g. the bus is not as stable as racing car, when they come to turn a corner at high speed. For safety reasons, the c.g of a vehicle should therefore be as low as possible.

M. Arshad
0300-9412902

UNIT 6

**Work, Power
and Energy**

**O Level
Physics Teacher's Notes**

**M. A. Chaudhary
Cell: 0300-9412902**

Syllabus 2017 – 18**Work, Power and Energy**

- Basic Definitions
- Kinetic Energy
- Gravitational Potential Energy
- Different forms of energy
- Principle of Conservation of energy
- Energy conversions in the production of electricity
- Environmental issues of power generation
- Renewable and Non-renewable energy sources
- Einstein's mass energy equation
- Nuclear Fission and Nuclear Fusion

Unit-6 WORK, POWER AND ENERGY

BASIC DEFINITIONS:

Work: Work is said to be done, when a force acts on a body and body covers some distance.

$$\text{Work} = \text{Force} \times \text{distance}$$

Unit or S.I Unit of work is Joule (J).

Power: Rate of doing work.

$$\text{Power} = \frac{\text{work}}{\text{time}}$$

Unit: S.I unit J of power is watt (W).

Energy: It is the ability of doing work.

Unit: Joule

KINETIC ENERGY:

The energy possessed by a body, due to its motion is called Kinetic energy.

$$E_k = \frac{1}{2} mv^2$$

Where m = mass of body.

v = speed of body.

E_k = kinetic energy.

GRAVITATIONAL POTENTIAL ENERGY:

It is the energy possessed by a body, when it is vertically elevated in gravitational field.

$$E_p = mgh$$

Where m = mass of body.

g = gravitational field strength.

h = height to which body is raised.

M. Arshad Ch.
0300-9412902

DIFFERENT FORMS OF ENERGY:

| Forms of Energy | | Some common Examples |
|-----------------|---|---|
| 1 | Chemical | Fuels such as oil, wood, coal, electric cells, food and explosives. |
| 2 | Nuclear | Atomic bombs, nuclear reactors. |
| 3 | Radiant | The electromagnetic (E.M.) spectrum such as visible light, radio waves, infra-red (IR), Ultra Violet (UV), X-rays and γ -rays. |
| 4 | Electrical | The energy associated with the current in an electric drill, power tools and an immersion heater, and electrical appliances. |
| 5 | Internal Energy | The energy possessed by the atoms or molecules of matter in the form of kinetic energy and potential energy. |
| 6 | Mechanical (K.E & P.E) | <p>(a) kinetic energy: all objects in motion.</p> <p>(b) potential energy:</p> <ol style="list-style-type: none"> a waterfall, raised objects. Compressed or stretched springs, the bent condition of a diving board, the stretched band of a catapult. |
| | <ol style="list-style-type: none"> Gravitational P.E. elastic | |

PRINCIPLE OF CONSERVATION OF ENERGY:

Energy can neither be created nor destroyed, however it can be converted from one form to the other and total amount of energy remains constant.

Example:

A swinging pendulum obeys law of conservation of energy.

- At point A, E_p is maximum and E_k is zero.
- At point O, E_k is maximum and E_p is minimum.
- At point B again E_p is maximum and E_k is zero.

Therefore $E_p \rightarrow E_k \rightarrow E_p$ and so on, but at every point sum of E_p and E_k is always constant.

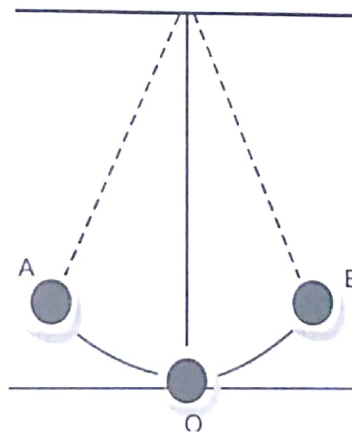

Major energy conversions:

Discuss the major energy changes in the following cases.

1. **An object falling from certain height on a floor.**

Ans: Gravitational $E_p \rightarrow E_k \rightarrow$ Sound & heat energy.

2. **A cyclist riding the bicycle up the hill.**

Ans: Chemical energy $\rightarrow E_k \rightarrow E_p$

3. An object released from a catapult, hitting the target.
 Ans: Elastic $E_p \rightarrow E_k$, sound and heat energy.
4. To switch on filament lamp connected to battery.
 Ans: chemical energy \rightarrow electrical energy \rightarrow light & heat energy.
5. A diver on a spring board, jumping into pool.
 Ans: Chemical energy \rightarrow Elastic $E_p \rightarrow E_k \rightarrow$ Sound energy.
6. A person knocking the nail into wooden block with hammer.
 Ans: Chemical energy $\rightarrow E_p \rightarrow E_k \rightarrow$ sound & heat energy.

ENERGY CONVERSIONS IN THE PRODUCTION OF ELECTRICITY:

- Burning of Coal:**
 Chemical energy \rightarrow heat energy \rightarrow steam energy \rightarrow kinetic energy \rightarrow electrical energy.
- Hydro-electric Generations:**
 Gravitational potential energy \rightarrow Kinetic energy \rightarrow Electrical Energy.
- Windmills:**
 Wind energy \rightarrow Kinetic Energy \rightarrow electrical energy .
- Nuclear Power Generation:**
 Nuclear Energy \rightarrow heat energy \rightarrow steam energy \rightarrow kinetic energy \rightarrow electrical energy.
- Solar Energy:**
 Solar energy \rightarrow electrical energy.
- Geo-thermal Energy:**
 Heat energy \rightarrow steam energy \rightarrow kinetic energy \rightarrow electrical energy.

Block Diagram of Electricity Generation:

Fuel such as coal, oil and natural gas are stored forms of chemical energy. The burning of fuel is used to heat up water which produces steam. The steam energy then converted to K.E of turbine, which produces electricity. The major energy conversions, from burning of fuel are:

Chemical energy \rightarrow Heat energy \rightarrow steam energy \rightarrow K.E. \rightarrow electrical energy

The block diagram for electricity generation is:

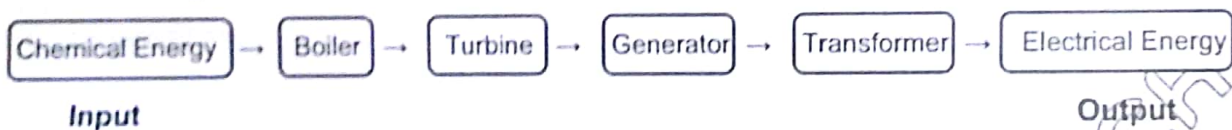

ENVIRONMENTAL ISSUES OF POWER GENERATION:

- > The burning of fuel like coal causes air pollution and produces harmful gases like CO_2 .
- > The construction of huge dams cause destruction of forests of habitats in large space.
- > The Nuclear power generation produces radioactive waste and by products, which remains harmful for long time.

RENEWABLE AND NON-RENEWABLE ENERGY SOURCES:

- A source of energy which is infinite and will never run out is known as the renewable source of energy.
 e.g. wind, tidal, geothermal, hydroelectric, solar.
- A source of energy which is finite and cannot be replaced easily when it runs out is known as non-renewable energy source.
 e.g. coal, oil, gas, radioactive nuclei.

EINSTEIN'S MASS ENERGY EQUATION:

The mass can be changed into energy and energy can be changed into mass i.e. mass and energy are interchanged by the equation.

$$E = mc^2$$

where m = decreases or loss in mass.

E = energy produced.

c = speed of light = $3 \times 10^8 \text{ ms}^{-1}$

NUCLEAR FISSION AND NUCLEAR FUSION:

1. **Nuclear Fission** is the splitting up of heavy nucleus into two lighter nuclei with release of energy. The thermal energy released from nuclear fission can be used to heat water to produce steam. The steam is then used to drive turbines to produce electricity.
2. **Nuclear Fusion** is the combining up of two lighter nuclei to produce a heavy nucleus with release of energy. This reaction occurs only in sun because extremely high temperature is required for this reaction. We have to invent a usable Fusion Reactor.

Efficiency: it is the ratio of power output to power input.

Formula:

$$\text{Efficiency} = \frac{\text{Power Output}}{\text{Power Input}} \times 100$$

or

$$\text{Efficiency} = \frac{\text{Energy Output}}{\text{Energy Input}} \times 100$$

The efficiency of a machine can never be 100% because some of the energy is lost in the surroundings in the form of heat, sound etc.

RESEARCH COLLECTIONS
 For Book ID: 1000-51111

UNIT 7

Pressure

**O Level
Physics Teacher's Notes**

**M. A. Chaudhary
Cell: 0300-9412902**

Syllabus 2017 – 18

Pressure

- Pressure of Liquid
- Atmospheric Pressure
- Experiment to demonstrate Atmospheric pressure
- The Simple Mercury Barometer
- The Manometer
- Transmission of pressure through liquids

Unit-7 PRESSURE

PRESSURE:

Pressure is the force acting per unit area.

Formula:

$$\text{Pressure} = \frac{\text{Force}}{\text{Area}}$$

Unit: SI unit of pressure is Pascal (Pa).

$$1\text{Pa} = \text{N/m}^2$$

Factors on which pressure depends:

1. **Force or Weight of Object:**

The greater is the weight of an object, the larger is the pressure.

$$\text{i.e. } P \propto F.$$

2. **Area in Contact with the object:**

Greater is the area in contact with the object, lesser is the pressure.

$$\text{i.e. } P \propto \frac{1}{A}$$

Examples:

- Suppose a single brick is lying on the table. If another brick is placed on the first one, then pressure increases, because force or weight increases.
- A brick lying vertically on the table exerts more pressure than horizontally, because there is less area in contact with table in vertical position.
- A girl wearing heel shoes exerts more pressure than flat sole shoes, because area in contact with heel shoes is less.

PRESSURE OF LIQUID:

The pressure of a liquid is defined by the relation

$$P = \rho gh$$

Where ρ = density of liquid.

g = gravitational field strength.

h = depth of liquid.

P = Pressure of a liquid.

Conclusion:

- 1) The greater the depth h , the greater is the liquid pressure. i.e. $P \propto h$
- 2) The pressure increases with the density of liquid, at given depth. i.e. $P \propto \rho$
- 3) The pressure of liquid increases with the increase of gravitational field strength i.e. $P \propto g$.

ATMOSPHERIC PRESSURE:

The pressure exerted due to the collision or bombardment of air molecules present in atmosphere is called atmospheric pressure.

The atmospheric pressure decreases with height. As height increases, concentration of air molecules decreases, so less collision occurs and atmospheric pressure decreases. The value of atmospheric pressure is approximately 100000 Pa. This standard pressure is sometimes called one atmospheric or one bar.

EXPERIMENT TO DEMONSTRATE ATMOSPHERIC PRESSURE:

Fig. shows a thin-walled metal can, attached to a vacuum pump. Before the air was pumped out, the pressure inside the can is equal to that outside. As the air is pumped out, a partial vacuum of very low pressure forms inside the can and immediately the great external atmospheric pressure crushes the can. It is assumed that the material of the can is thin or flexible.

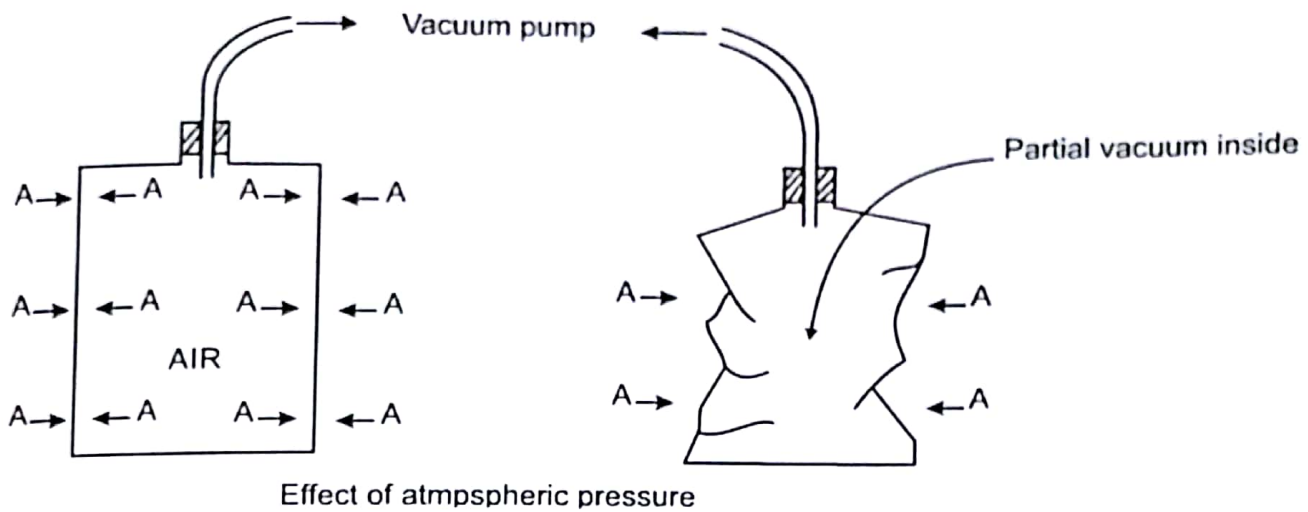

THE SIMPLE MERCURY BAROMETER:

Use: A barometer is an instrument for measuring atmospheric pressure.

Construction:

A barometer consists of a thick walled glass tube 1m long, closed at one end. It is fully filled with mercury.

- The open end of tube is placed downwards, in a mercury reservoir. The mercury column will drop to about 76cm or 760 mm as shown in fig.

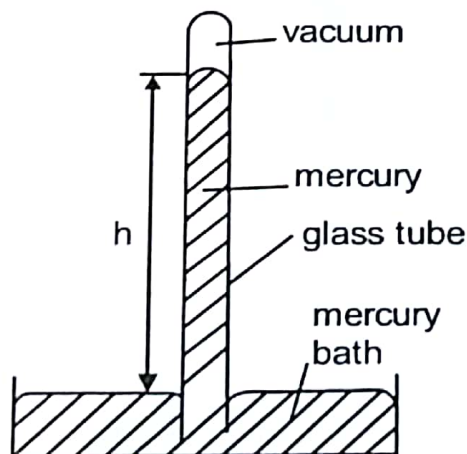

Read & Write Publications
For Books Order: 0336-531441

Calculation:

The height to which mercury column falls is measured and then the formula $P = \rho gh$ is applied to calculate atmospheric pressure, which is approximately 100000 Pa.

THE MANOMETER:

Use: It is used to measure gas pressure.

Construction:

The manometer consists of a U shape tube containing a column of liquid like mercury, oil or water. Initially the level of liquid is same at both ends because both ends are open to atmospheric Pressure. When shorter end is connected to gas supply, the liquid rises in the longer end because gas pressure is greater than atmospheric Pressure.

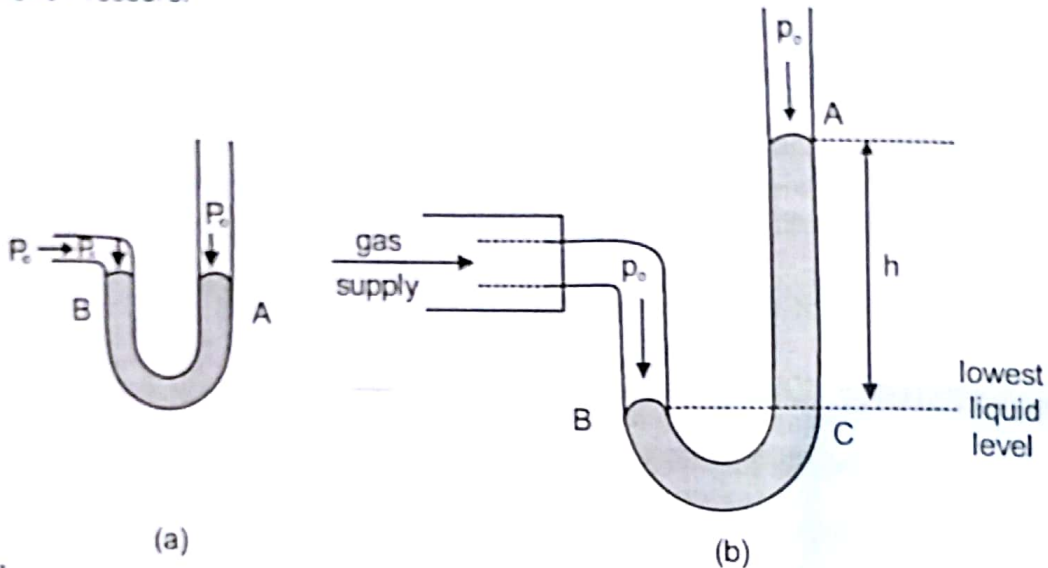
**Calculation:**

The height h to which liquid rises in the longer end is measured. The gas pressure can be calculated by the relation.

Gas pressure = atmospheric Pressure + Pressure due to liquid column.

$$\text{i.e. } P_g = P_o + \rho gh$$

where P_g = gas pressure.

P_o = atmospheric Pressure.

ρgh = liquid column pressure

Note:

The height h of liquid in manometer can be changed by

1. Replacing the given liquid with another of different density.
2. Changing either gas pressure or atmospheric pressure.

No change occurs on height h if diameter of U-tube is changed.

TRANSMISSION OF PRESSURE THROUGH LIQUIDS**Pascal's Principle:**

The pressure is equally transmitted in all directions through the liquid.

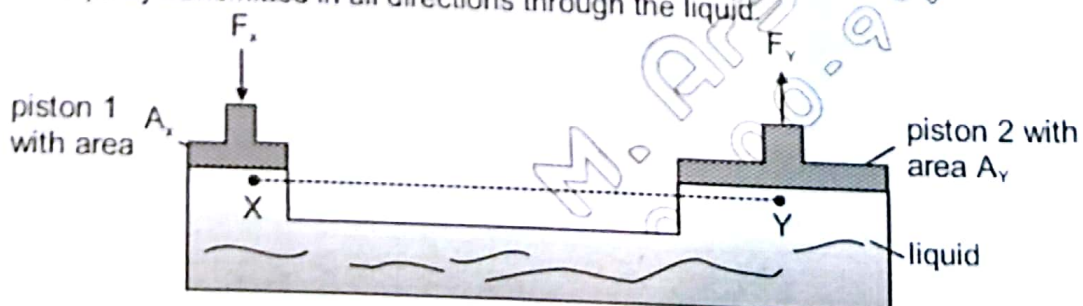

Suppose a force F_x is applied on piston 1 of Area A_x . The pressure of piston 1 at point X is equally transmitted at the same level to y. i.e.

$$\text{Pressure at X} = \text{Pressure at y}$$

$$(P)_x = (P)_y$$

i.e.

$$\frac{F_x}{A_x} = \frac{F_y}{A_y}$$

Where A_x = area of piston 1

A_y = area of piston 2

F_x = force on piston 1

F_y = force on piston 2

Hydraulic System:

The application of transmission of pressure in liquids is used in hydraulic brakes. The pressure on the brake pad is transmitted to the large piston on each side of a large disc on the wheel axle. This pressure causes the pistons to come into contact with disc. Due to force of friction between them, the car slows down.

The other applications of transmission of pressure in liquids are car jacks and car lifts.

Pressure-Volume relationship of a gas:

The intermolecular forces between gas molecules are negligible. The gas molecules are at large distances from each other. If pressure on a gas is increased, then gas molecules come close and the spaces between them reduce. Therefore as the pressure on a gas is increased, the volume of gas is reduced, provided that temperature remains constant.

This concept first was stated by Boyle.

Boyle's Law

The volume of a gas is inversely proportional to the pressure if temperature is kept constant.

$$\text{i.e. } v \propto \frac{1}{p} \text{ if } T = \text{constant}$$

The formula for Boyle's law is

$$P_1V_1 = P_2V_2$$

Where P_1 = Initial Pressure

V_1 = Initial Volume

P_2 = Final Pressure

V_2 = Final Volume

When a graph of p against v is plotted, the result is smooth curve, as shown below

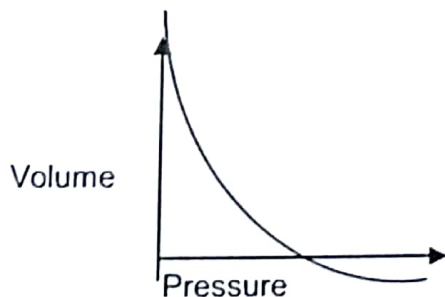

Read & Write Publications
For Books Order: 0336-531411

UNIT 8

Kinetic Model Of Matter

**O Level
Physics Teacher's Notes**

**M. A. Chaudhary
Cell: 0300-9412902**

Syllabus 2017 – 18

Kinetic Model of Matter

- Properties of solids, liquids and gases
- Kinetic Molecular Theory of Gases
- Effect of temperature on molecular motion
- Pressure of a gas
- Factors effecting evaporation
- Cooling effect of evaporation

Unit-8 KINETIC MODEL OF MATTER

PROPERTIES OF SOLIDS, LIQUIDS AND GASES:

- Solids:**
- Fixed shape and volume.
 - Normally hard and rigid.
 - Incompressible.
 - Large force needed to change shape.
 - High density.
- Liquids:**
- Fixed volume, occupy shape of container.
 - Can flow easily.
 - Incompressible.
 - High density.
- Gases:**
- Neither fixed shape nor fixed volume.
 - Can flow more easily.
 - Compressible.
 - Low density.

The distinguishing properties between solids, liquids and gases can be summarized in the table below.

| | | Solid | Liquid | Gas |
|-----|--------------------------|------------------------------|---------------------------------|---------------------------------|
| (a) | Inter-particle forces | Very strong attraction | Strong attraction | Weak attraction |
| (b) | Inter-particle distances | Close | Far apart | Very far apart |
| (c) | Shape | Fixed shape | Takes the shape of container | Entirely fills container |
| (d) | Compression | Not easily compressed | Not easily compressed | Easily compressed |
| (e) | Motion of particles | Vibration about fixed points | Random rotation and Translation | Random rotation and Translation |

KINETIC MOLECULAR THEORY OF GASES:

Key Points:

- All gases are made up of tiny particles called as atoms or molecules.
- The gas particles are always in continuous and random motion.

EFFECT OF TEMPERATURE ON MOLECULAR MOTION:

The increase in temperature causes the following changes in the motion of gas molecules.

- A. At high temperature molecules have higher kinetic energy.
- B. At high temperature molecules have greater speed.
- C. At high temperature molecules become more vigorous.
- D. At high temperature molecules collide more frequently, resulting in more pressure.

PRESSURE OF A GAS:

According to kinetic molecular theory, gas molecules are always in continuous and random motion. They collide with each other and with the walls of container. Due to collisions they exert a force per unit surface area of container and pressure is produced.

Evaporation:

The liquid molecules are always moving randomly at different speeds. When the molecules gain heat energy, their average k.e. increases. The molecules which are more energetic are able to overcome force of attraction of liquid and escape from the surface of liquid into atmosphere. This effect is called evaporation.

FACTORS EFFECTING EVAPORATION:

1. **Increase of Temperature:**

This makes the molecules more faster so that they have enough energy to escape from the liquid and rate of evaporation increases.

2. **Increase of Surface area:**

The rate of evaporation increases with the exposed surface area of the liquid. A large surface area means more molecules can escape from the surface.

3. **Decrease of humidity:**

If there are water vapours present in the air, then rate of evaporation decreases. However draught above the surface of liquid increases evaporation.

4. **Increase of wind speed:**

When air moves across a liquid surface, it carries away escaped molecules above the liquid and reduces their chances of returning back, so evaporation increases.

5. **Decrease of atmospheric Pressure:**

Decreasing the atmospheric Pressure increases the rate of evaporation, because more molecules escape the surface of liquid, in the presence of less atmospheric Pressure.

6. **Decrease the boiling point:**

The lower the boiling point of a liquid, the higher the rate of evaporation. The volatile liquids evaporate faster than non-volatile liquids.

COOLING EFFECT OF EVAPORATION:

During the evaporation, molecules gain heat energy from surroundings. The more energetic molecules escape and take a lot of energy with them. Hence the average k.e of the remaining molecules decreases and the temperature falls, causing the cooling effect.

Read & Write Publications
For Books Order: 0354731441

UNIT 9

**Measurement
Of
Temperature**

**O Level
Physics Teacher's Notes**

**M. A. Chaudhary
Cell: 0300-9412902**

Syllabus 2016 – 18**Measurement of Temperature**

- Heat and Temperature
- Fixed Points in a Thermometer
- Determination of Fixed Points
- Thermometric Property
- Choice of liquid in thermometer
- Types of Thermometer
- The advantages of thermocouple thermometer are

Unit-9 MEASUREMENT OF TEMPERATURE

HEAT AND TEMPERATURE:

- Heat is a form of energy which flows from a body at high temperature to a body at low temperature.
- Temperature is a measure of degree of hotness or coldness of a body.

FIXED POINTS IN A THERMOMETER:

1. Lower Fixed Point or Ice Point:

It is the temperature at which pure ice melts, at constant atmospheric pressure. It is assigned a value of 0°C .

2. Upper Fixed Point or Steam Point:

It is the temperature at which pure water boils, at constant atmospheric pressure. It is assigned a value of 100°C .

DETERMINATION OF FIXED POINTS:

1. Determination of Ice Points:

Immerse the bulb of thermometer into ice cubes, contained in a funnel. The mercury level of thermometer keeps on decreasing and after sometime it becomes steady at a fixed point. This point is marked as 0°C and called as ice point.

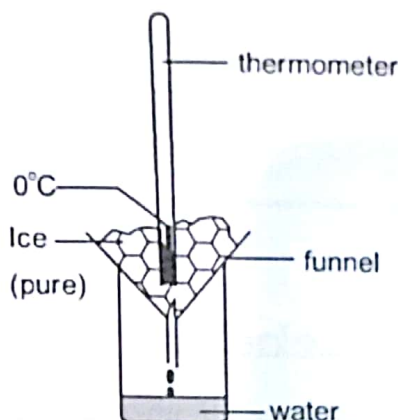

2. Determination of steam point:

Immerse the thermometer bulb into steam, above the boiling water. The mercury level of thermometer keeps on increasing and after sometime it becomes steady at a fixed point. This point is marked as 100°C and called as steam point.

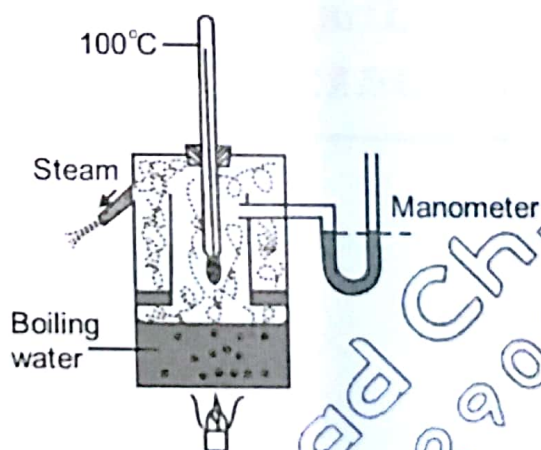

THERMOMETRIC PROPERTY:

It is the property of a substance, which varies continuously with temperature change. A thermometer is constructed on the basis of thermometric property of a substance. Examples of properties are:

| Thermometric Property | Type of Thermometer |
|-----------------------|----------------------------------|
| Volume of liquid | Liquid-in-glass Thermometer. |
| Electromotive force | Thermocouple Thermometer. |
| Resistance | Resistance Thermometer. |
| Pressure of gas | Constant volume gas Thermometer. |

Calibration a temperature scale:

The marking of divisions of temperature on a thermometer is called its calibration. The steps involved for constructing a temperature scale are:

- > Choose a thermometric substance.
- > Determine two fixe points i.e. ice point and steam point. Divide distance between fixed points into 100 equal divisions. Each division is marked as 1°C.

To determine temperature on an un-calibrated thermometer:

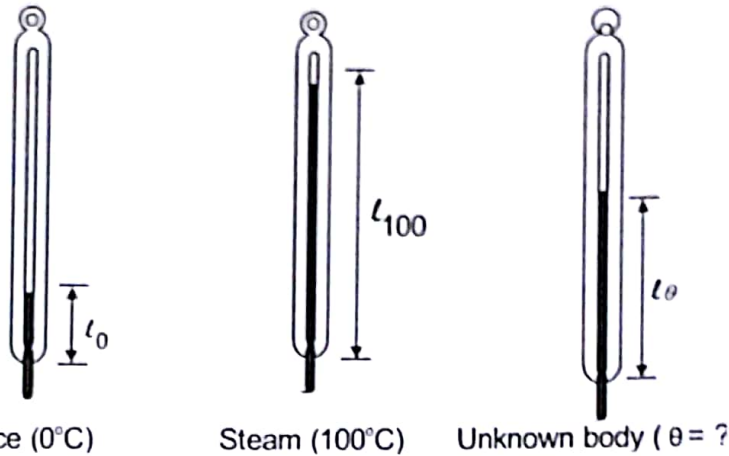

The unknown temperature on an un calibrated thermometer is determined by the formula:

$$\theta = \frac{L_{\theta} - L_0}{L_{100} - L_0} \times 100$$

where

- L_0 = length of mercury column at ice point 0°C.
- L_{100} = length of mercury column at steam point 100°C.
- L_{θ} = length of mercury column at unknown temperature θ °C.
- θ = Unknown temperature to be calculated in °C.

CHOICE OF LIQUID IN THERMOMETER

Advantages of Mercury:

- It has a wide range of temperature from -39°C to 357°C.
- It is a good conductor of heat.
- It does not stick to the walls of tube of thermometer.
- It is silver shiny liquid, easily visible.
- It does not evaporate.

Disadvantages of Mercury:

- It can not measure temperature below -39°C, of extremely cold regions.
- It is poisonous
- It is expensive.
- Its expansibility is low.

Advantages of Alcohol:

- Its freezing point is -115°C, so it can measure, any temperature of a cold region.
- It expands uniformly.
- It is cheap as well as safe liquid.
- Its expansivity is high.

Disadvantages of Alcohol:

- Its boiling point is just 78°C, cannot measure high temperatures.
- It sticks to the walls of tube.
- It is colourless liquid, not easily visible.

- It can evaporate at room temp.

Basic terms of thermometer

- Sensitivity
- Range
- Responsiveness
- Linearity

1. Sensitivity:

It is increase in mercury length of thermometer, per degree rise in temperature.

i.e. $\text{Sensitivity} = \frac{\Delta L}{\Delta \theta}$

Where ΔL = increase in mercury level.
 $\Delta \theta$ = increase in temperature.

The sensitivity is measured in mm/°C.

The sensitivity of a thermometer can be increased:

- By using a capillary tube, of narrow bore.
 - By using a large glass bulb or increasing volume of mercury.
 - By using a liquid of high expansivity.
2. **Range:** The minimum and maximum temperature that a thermometer can measure, determines its range. The range varies with the type of thermometer. The range of a thermometer can be increased:
- By using a capillary tube of wide bore.
 - By using a smaller bulb.
 - By using a liquid of low expansion.

3. Responsiveness:

It is the ability of a thermometer to respond quickly to register the changes in temperature. The responsiveness of a thermometer can be increased:

- By using a glass bulb of thin surface.
- By using a liquid of high expansibility.

4. Linearity:

The increase in mercury length is directly proportional to the increase in temperature of a thermometer. This property of thermometer is called linearity and its scale is said to be linear. The linear scale can be achieved:

- By using a liquid which expands uniformly.
- By using a capillary tube of uniform bore.

TYPES OF THERMOMETER:

The clinical Thermometer:

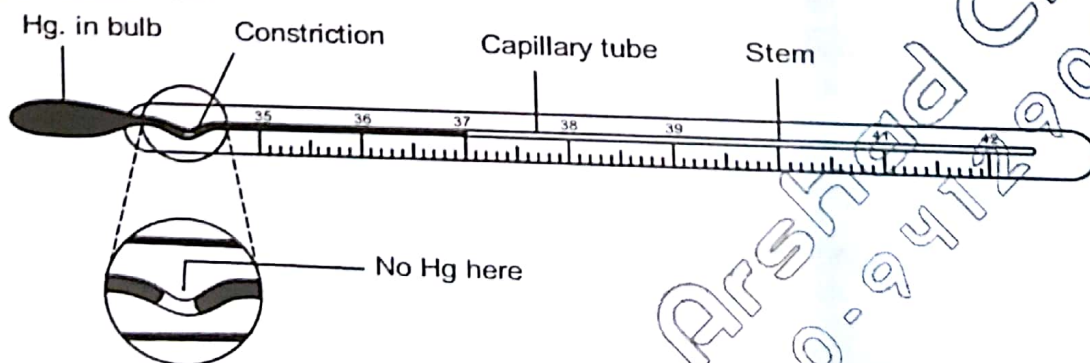

| Parts | Purpose or working |
|-------------------|---|
| 1) Bulb | It is made up of a thin glass, for rapid conduction of heat. The bulb contains mercury. |
| 2) Capillary tube | A tube with narrow bore, in which mercury rises on expansion. It's one end is closed and other is open in bulb. |
| 3) Constriction | It is bend in capillary tube. It stops backward flow of mercury into bulb, for a while. |
| 4) Stem | It is outer casing of thermometer normally made up of glass or plastic. It is often oval in shape to magnify the reading. |
| 5) Scale | The temperature divisions marked on stem is the scale of thermometer. The scale is limited from 35°C to 42°C on a clinical thermometer. |

Thermocouple Thermometer:

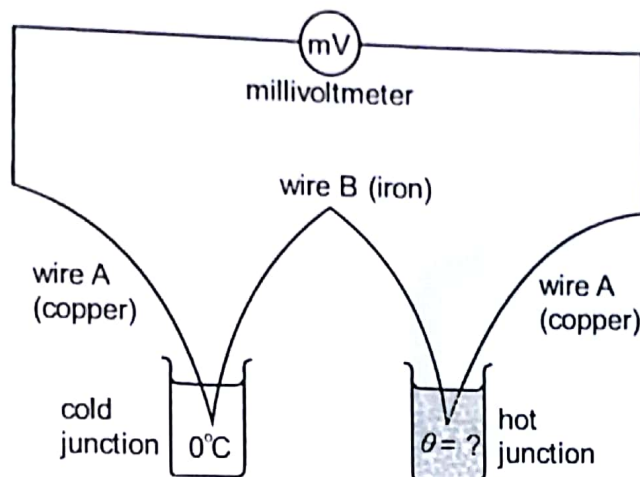

A thermocouple thermometer consists of two wires of different metals. The ends of wires are joined together to form junctions. One junction is kept at steady low temperature and other one at high unknown temperature. Due to temperature difference of two junctions an e.m.f – electromotive force is set up. The value of emf is measured with milli voltmeter and then converted to temperature scale.

THE ADVANTAGES OF THERMOCOUPLE THERMOMETER ARE:

- It can measure a wide range of temperature from -200°C to 1500°C .
- It is highly responsive thermometer.
- It can measure rapid changes in temperature.
- It is very sensitive thermometer.

Read & Write Publications
For Books Order: 0336-5314141

UNIT 10

**Transfer Of
Thermal
Energy**

**O Level
Physics Teacher's Notes**

**M. A. Chaudhary
Cell: 0300-9412902**

Syllabus 2017 – 18

Transfer of Thermal Energy

- Applications of Conduction
- Applications of Convection
- Applications of radiation

Unit-10 TRANSFER OF THERMAL ENERGY

There are three methods of heat transfer.

- **Conduction**
- **Convection**
- **Radiation**

The detail of each method is described below:

- **Conduction:** Conduction is the transfer of heat mainly through solids. When heat is supplied to one end of a solid, then its molecules gain heat energy and vibrate vigorously. The k.e of vibrating molecules is passed on to the neighboring molecules and so on. In this way heat is transferred throughout the solid by vibration of molecules from one end to the other.
- **Convection:** Convection is the transfer of heat through fluids (liquid and gases). When heat is supplied to a liquid, then liquid expands and becomes less dense. The less dense liquid rises upwards and more dense liquid at the top sinks downwards. Therefore a cyclic process of liquid movement takes place due to density difference and heat is transferred throughout the liquid.
- **Radiation:** Radiation the transfer of heat mainly through vacuum. Unlike conduction and convection, radiation does not require any medium for heat transfer. The heat is transferred in the form of electromagnetic radiations (mainly infra red), which do not require any medium. e.g. heat energy from the sun reaches the earth by the process of radiation.

Experiments to demonstrate conduction, convection and radiation.

Experiment# 1: To investigate the thermal conduction through different solids.

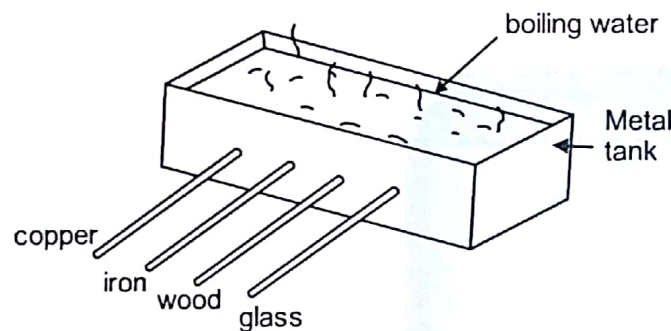

Four rods of different materials but of the same size, coated with wax are inserted in a metal tank. Pour boiling water into tank, so that the ends of rods are submerged. The level to which wax melts on different rods, determines the conduction rate of solids.

Experiment # 2: To demonstrate that water is a poor conductor of heat.

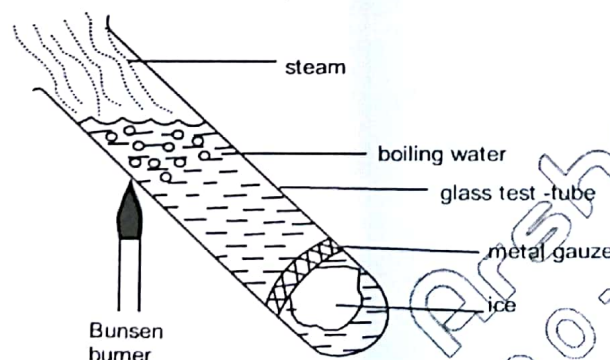

Place the ice cube at the bottom of test tube which is filled with water. Cover the ice cube with wire gauze, so that ice cube may not float. Heat the test tube at the upper end. It has been observed that water boils at the top but ice does not melt at the bottom. It shows that water is a poor conductor of heat.

Experiment #3: To demonstrate convection through the liquid.

Fill the flask with water. Keep few crystals of Potassium Permanganate ($KMnO_4$) at the bottom of flask. Heat the flask from bottom. The water at the bottom being less dense rises upwards, along with crystals of $KMnO_4$. The purple streaks moving upwards and then downwards are observed in the flask, which show the presence of convection current.

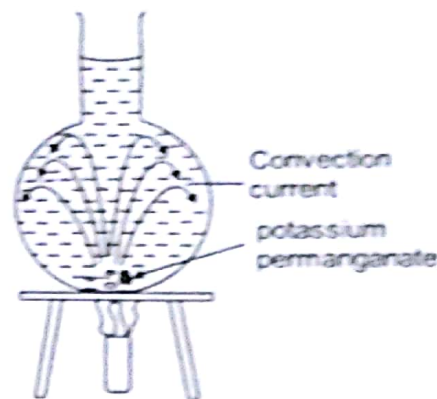

Experiment # 4: To demonstrate convection through air.

Keep the burning candle at the bottom of chimney A and smoldering paper at the top of chimney B. The hot air above candle rises upwards and more dense air along with smoke enters from chimney B and travels towards chimney A. The path of smoke indicates presence of convection current.

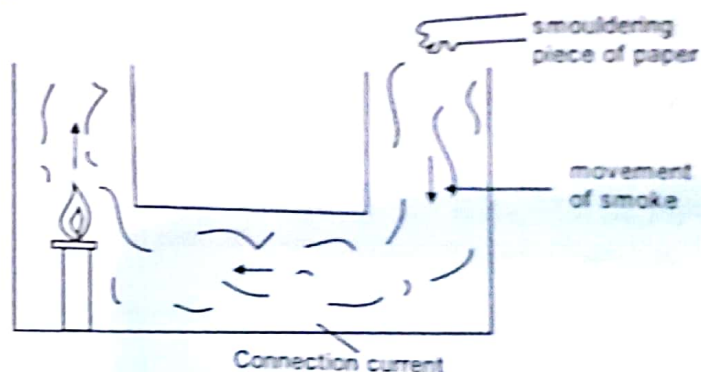

Experiment # 5: To demonstrate that black surface absorbs more infra red radiations than white surface.

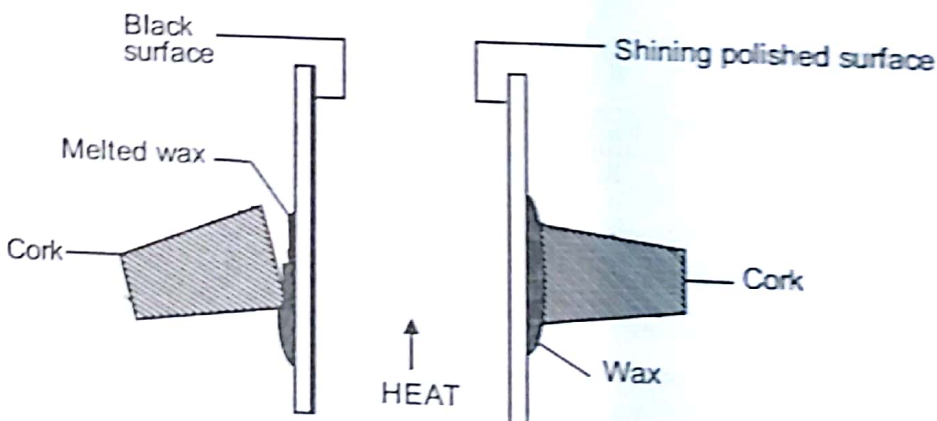

Take two metal plates of same size, one is dull black and other one smooth shiny. Stick Corks with wax on opposite sides of the plates. Heat the plates equally. It has been observed that wax attached to black plate melts and its Cork falls down earlier than that of white plate.

Experiment # 6: To demonstrate that black surface emits more infra-red radiations than white surface.

Take a metal tank and fill it with hot water. Make one side of container dull black and other shiny white. Keep two metal plates holding wax and Cork at equal distances on both sides of tank. It has been observed that wax melts earlier and Cork falls down, from the plate facing black side of tank.

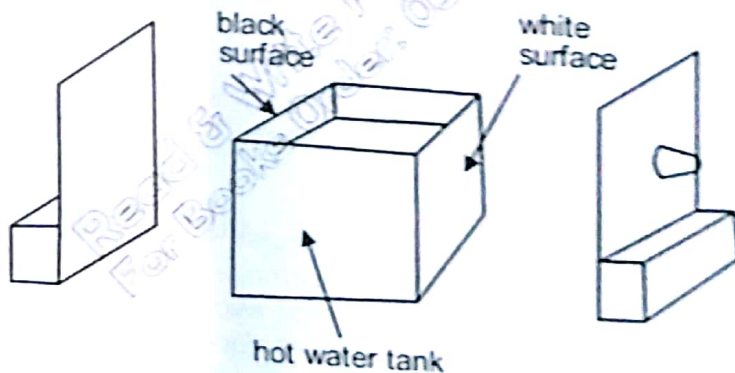

APPLICATIONS OF CONDUCTION

Good Conductors:

The substances which can conduct heat easily e.g. all metals are good conductors. The uses of good conductors are:

- Cooking utensils like kettles, saucepans, boilers etc are made up of stainless steel.
- Mercury, a good conductor of heat, is used in thermometer.
- Soldering iron rods are made of iron, with tip made of Copper, as copper is much better conductor of heat than iron.

Bad Conductors:

The substances which do not conduct heat, are called bad conductors or insulators, e.g. glass, wood, plastic, rubber and materials containing trapped air like wool, fiber glass etc. The uses of bad conductors are:

- Handles of cooking utensils are made up of insulators.
- Fiber glass and polystyrene foam which trap air are used in the walls of houses and refrigerators as insulators.
- Birds have feathers and animals like cats or polar bears have fur to trap air, which act as insulator.

APPLICATIONS OF CONVECTION

- Formation of sea breeze and land breeze.

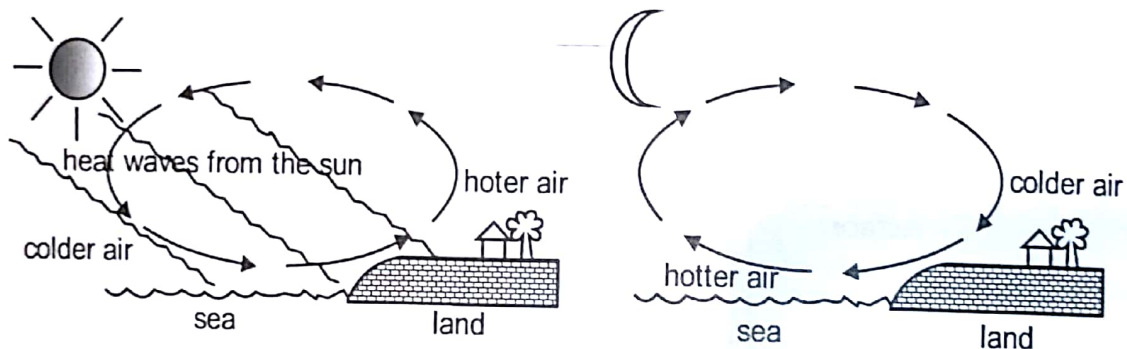

During day, hot air above the land expands and becomes less dense and rises upwards. The cool air from sea being more dense moves towards land, called as sea breeze. At night reverse process occurs i.e. more dense air from land moves towards sea, called as land breeze.

- The cool air produced by a.c, being more dense sinks downwards and warm air, being less dense in the room, rises upwards. The warm air is cooled by a.c and re-circulated, producing convection current.
- The heating coil of an electric kettle is placed at the bottom of the kettle. The water at the bottom is heated and becomes less dense, rises upwards. The cool water at the top sinks downwards, producing convection current.

APPLICATIONS OF RADIATION

- Shiny teapots:**

The shiny teapots can keep tea warm for longer time than black teapots as the shiny surfaces are bad emitters of heat radiations.

- Green House**

The radiations from sun pass through the glass walls and glass roof of green house. The radiations are absorbed by the soil and plants. The radiations emitted by contents of green house being weaker are unable to escape from green house. This causes the temperature inside the green house to rise, which is good for growth of plants.

c) Vacuum Flask:

A Vacuum flask reduces the heat losses by four ways.

- Conduction
- Convection
- Radiation
- Evaporation

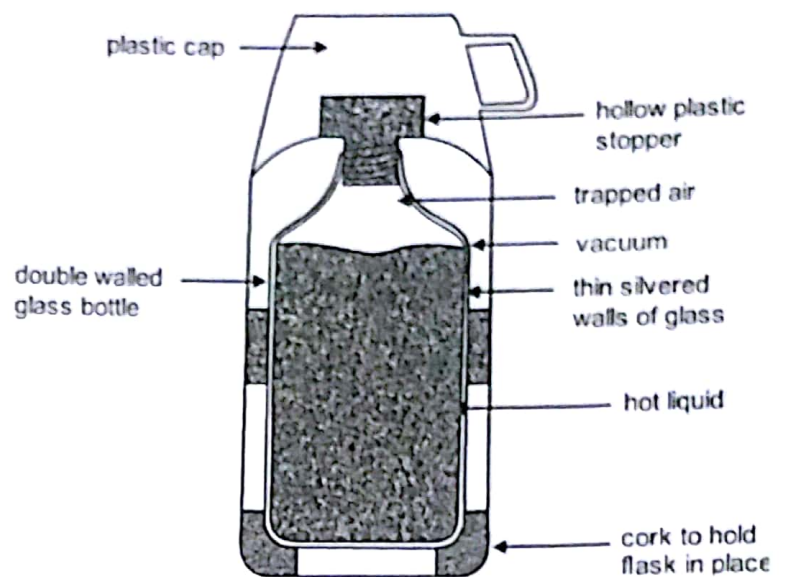

- The heat lost by conduction is minimized by vacuum, trapped air and plastic stopper.
- The heat lost by convection is minimized by vacuum and plastic stopper.
- The heat lost by radiation is minimized by polishing the walls of glass silvered.

The heat lost by evaporation is minimized by plastic stopper and plastic cup.

Heat transfer in or from a room or building***The heat can be transferred into building or room:***

- By conduction through the walls and roof. The atoms or molecules of walls and roof gain heat energy and pass on to neighboring atoms and so on, till the heat is conducted inside.
- The heat radiations can pass into building through the glass windows.
- The hot roof and walls emit infra-red radiations into room, which keep the room warm.

The heat can be transferred from a building:

- The heat from the building is conducted outside by walls and roof, due to vibration of atoms or molecules, which lose energy to surroundings.
- The heat energy from roof is lost by convection i.e. air comes in contact with roof, becomes hot and rises upwards.
- The roof being hotter than the surroundings emit infra-red radiations and loses energy.

Thermal insulation of a building:

The heat energy lost from a building can be prevented by following methods.

1. Fitting carpets on the floor.
2. Insulating the roof.
3. Using cavity walls.
4. Using wooden floors.
5. Painting walls and roof white.
6. Using double glazed windows.
7. Using fiber glass and polystyrene in walls and roof.

Read & Write Publications
For Books Order: 0336-537441

UNIT 11

**Thermal
Properties Of
Matter**

**O Level
Physics Teacher's Notes**

**M. A. Chaudhary
Cell: 0300-9412902**

Syllabus 2017 – 18**Thermal Properties of Matter**

- Internal Energy
- Difference between boiling and evaporation
- Specific latent heat of fusion
- Specific latent heat of vaporation
- Molecular explanation of latent heat
- Graphical representation of heating process
- Graphical representation of Cooling Process
- Applications of Thermal Expansion
- Effect of temperature changes on volume

Unit-11 THERMAL PROPERTIES OF MATTER

INTERNAL ENERGY:

It is the sum of the Kinetic energy and potential energy of molecules of a substance. The internal energy depends on the temperature i.e. higher is the temperature the more is the k.e and P.e of molecules of a substance and higher is its internal energy.

Heat Capacity:

It is the heat energy required to raise the temperature of any mass of a substance through 1K.

i.e. $Q = C\Delta\theta$

Where Q = Heat energy supplied (J)
 $\Delta\theta$ = increase in temperature (K or °C)
 C = Heat Capacity
 The Heat capacity is measured in JK⁻¹ or J°C⁻¹

Specific Heat Capacity:

It is the heat energy required to raise the temperature of 1Kg of a substance through 1K.

i.e. $Q = mc\Delta\theta$

where Q = Heat energy supplied (J)
 m = mass of substance (Kg)
 $\Delta\theta$ = increase in temperature (K or °C)
 c = specific heat Capacity.
 The Unit of specific heat capacity is JKg⁻¹ K⁻¹ or JKg⁻¹°C⁻¹.

Define:

- **Melting and Solidification**
- **Boiling and Condensation**

a) Melting and Solidification:

- Melting is the change of state from solid to liquid. The change occurs at a fixed or constant temperature. This particular temperature is called as melting point.
- The reverse process of changing a liquid to a solid is called solidification. A pure substance solidifies at a temperature equal to its melting point. During solidification temperature remains constant and heat is released by the substance.

b) Boiling and Condensation:

- Boiling is the change of state from a liquid into a vapour. The change occurs at a fixed or constant temperature. This particular temperature is called as boiling point.
- Condensation is the process whereby vapour changes into liquid at the same constant temperature. Heat is given out during condensation.

DIFFERENCE BETWEEN BOILING AND EVAPORATION:

| Boiling | Evaporation |
|--|--|
| 1. Occurs at a fixed temperature | 1. Occurs at any temperature |
| 2. Quick process | 2. Slow process |
| 3. Takes place within the liquid | 3. Takes place only on the surface of the liquid |
| 4. Bubbles are formed in the liquid | 4. No bubbles are formed in the liquid |
| 5. Temperature remains constant during boiling | 5. Temperature may change |
| 6. Heat is supplied by an energy source | 6. Heat is absorbed from the surroundings |

Define

- Latent Heat.
- Specific latent heat of fusion.
- Specific latent heat of vaporization.

Latent Heat: The amount of heat energy required to change the substance from one state to the other, at a constant temperature is called latent heat.

SPECIFIC LATENT HEAT OF FUSION:

The amount of heat energy required to change 1Kg solid into liquid and vice versa, without change in temperature.

i.e. $Q = ml_f$

where

Q = Quantity of heat energy (J)

M = mass of substance (Kg)

l_f = latent heat of fusion.

The SI Unit of specific latent heat of fusion is JKg^{-1} .

SPECIFIC LATENT HEAT OF VAPORIZATION:

The amount of heat energy required to change 1Kg liquid into vapours and vice versa, without change in temperature.

i.e. $Q = ml_v$

Where Q = Quantity of heat energy (J)

m = mass of substance (Kg)

l_v = latent heat of vaporization.

The SI Unit of specific latent heat of vaporization is JKg^{-1} .

MOLECULAR EXPLANATION OF LATENT HEAT:

Since there is strong force of attraction between solid as well as liquid molecules, energy is required to overcome the strong inter-molecular forces of attraction in the solids and in liquids. The amount of energy required for this purpose is called latent heat. The latent heat changes the substance from one state to the other, at constant temperature

GRAPHICAL REPRESENTATION OF HEATING PROCESS:

When ice at -10°C is heated, it first converts into water and then into steam. The temperature changes occurring with time are recorded. A graph between temperature and time is then plotted. This graph is called heating curve.

- From -10°C to 0°C , temperature of ice increases.
- The temperature of ice remains constant at 0°C . The ice is converting into water. The heat used during this state converts into latent heat of fusion.
- From X to Y, the temperature of water increases from 0°C to 100°C .

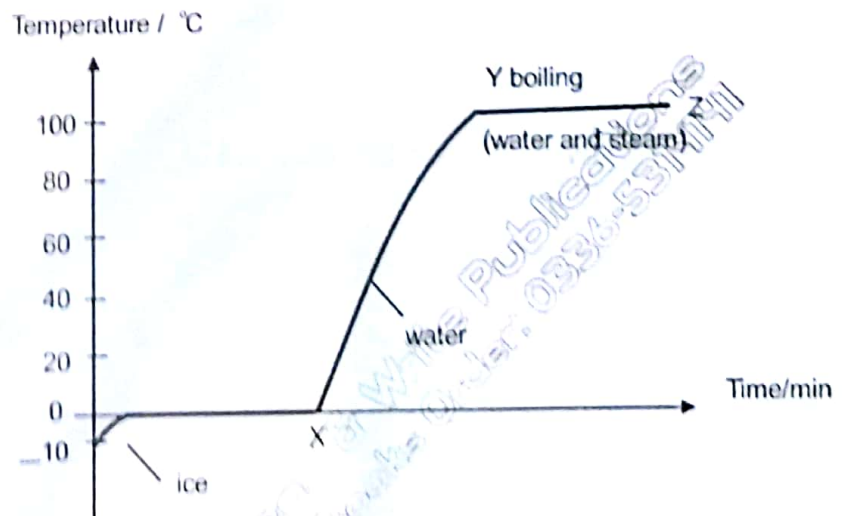

- From Y to Z, the temperature of water remains constant. The water is converting into vapours. The heat energy used during this state converts into latent heat of vaporization.

GRAPHICAL REPRESENTATION OF COOLING PROCESS:

When liquid Naphthalene at 90°C is cooled, it extracts heat out and solidifies. The temperature changes occurring with time are recorded and then a graph between temperature and time is plotted, called as cooling curve.

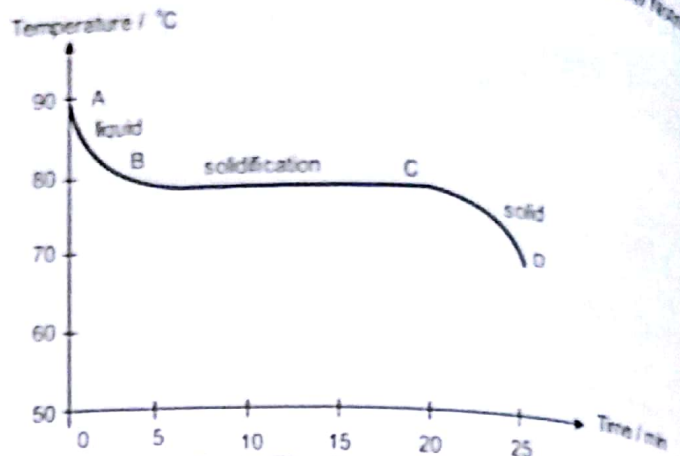

- From A to B, the temperature of liquid falls from 90°C to 79°C. The heat extracted out is the heat capacity of liquid.
- From B to C, the temperature of Naphthalene remains constant at 79°C. The liquid is solidifying and heat lost during this state is the latent heat of fusion.
- From C to D, the temperature of solid Naphthalene falls further and heat given out is the heat capacity of solid.

Thermal Expansion:

The increase in the volume of a substance on heating is called thermal expansion. When a substance is heated, its molecules gain heat energy and move apart from each other. The average gap between molecules increases and substance expands.

Order of Expansion:

The amount of expansion depends on the intermolecular forces of a substance. The stronger the intermolecular forces, the least the expansion and vice versa. For the same quantity of heat supplied, the following is the order of expansion.

Expansion of gases > expansion of liquids > expansion of solids.

The relative order of expansion of solids, liquids and gases is 1:10:100.

APPLICATIONS OF THERMAL EXPANSION

- A bimetallic strip is made up of two different metals. On heating, strip bends due to different rate of expansion, of given metals. On cooling, strip becomes straight again. A bimetallic strip is used in thermostats to maintain the temperature steady.

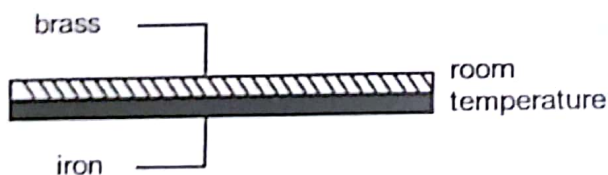

A bimetallic strip is straight at room temperature.

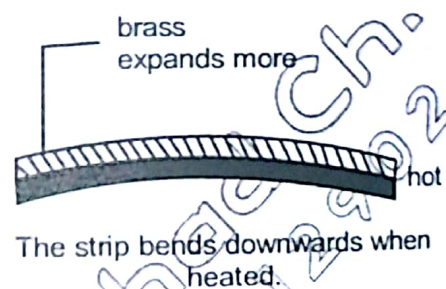

- Railway tracks can be bent and damaged on a very hot day if there is no allowance for the expansion of the rails.
- The overhead power lines expand and sag in summer and contract and tighten in winter.
- Concrete blocks of pavements and road surfaces are laid with soft material, which can be squashed when blocks expand in summer.

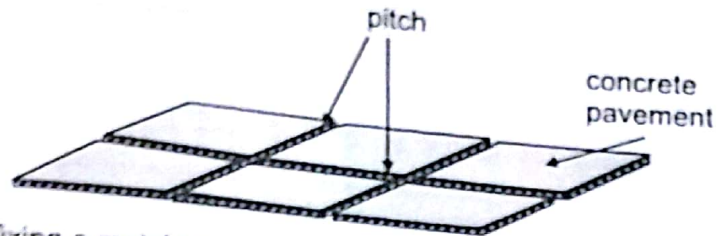

- The process of fixing a metal tyre on the wheel of a railway train is another application of thermal expansion. On heating, tyre expands and passes over the wheel. On cooling, tyre contracts to give a tight fit on the wheel.

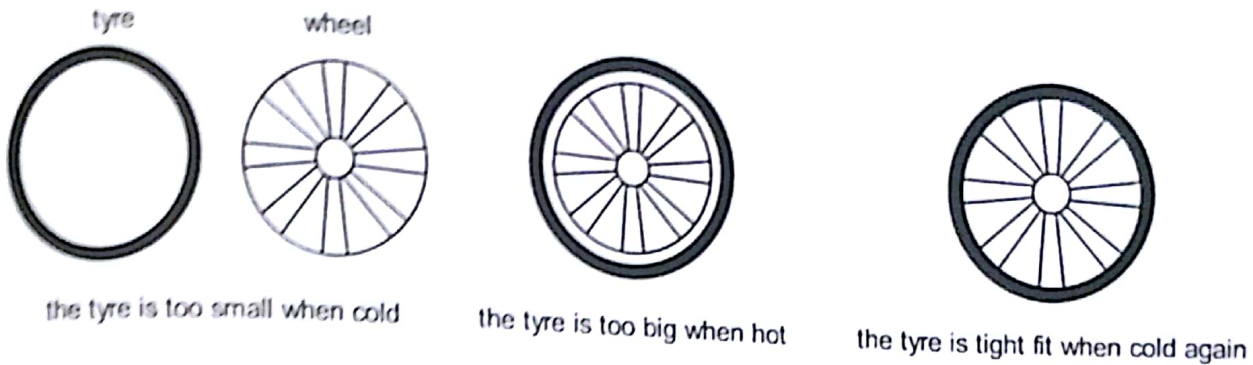

EFFECT OF TEMPERATURE CHANGES ON VOLUME:

When a substance is heated, then its volume increases with increase in temperature

- > In solids the increase in volume is extremely small with change in temperature so the effect on the density of solid is negligible.
- > In liquids, the increase in volume is large enough, with increase in temperature so there will be appreciable effects on density of liquids i.e. as temperature increases, volume increases and density of liquid decreases.
- > Since the increase in volume of gases is much greater so the density of gases is greatly affected with rise of temperature e.g. formation of sea and land breezes is the result of this effect.

Read & Write Publications
For Books Order: 0336-531141

UNIT 12

**Reflection And
Refraction Of
Light**

**O Level
Physics Teacher's Notes**

**M. A. Chaudhary
Cell: 0300-9412902**

Syllabus 2017 – 18**Reflection and Refraction of Light**

- Reflection of Light
- Refraction of Light
- Critical angle and Total Internal Reflection
- Application of Total Internal Reflection

Unit-12 REFLECTION AND REFRACTION OF LIGHT

REFLECTION OF LIGHT

When a light falls on shiny surface, it bounces back in the same medium. This effect is called reflection of light.

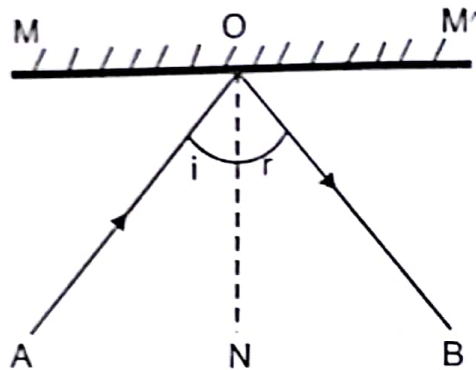

Where

MM = mirror
 Point O = Point of Incidence
 ON = normal
 OB = reflected ray.
 i = angle of incidence
 r = angle of reflection

Define:

- **Normal**
- **Angle of Incidence**
- **Angle of reflection**

- **Normal:**
The perpendicular drawn at the point of incidence.
- **Angle of incidence:**
The angle made between incident ray and the normal.
- **Angle of Reflection:**
The angle made between reflected ray and the normal.

Laws of Reflection:

- a) The angle of incidence is equal to angle of reflection.
- b) The incident ray, the reflected ray and the normal all lie in the same plane.

M. Arshad Ch.
 0300-9412902

Experiment: To verify that angle of incidence is equal to angle of reflection.

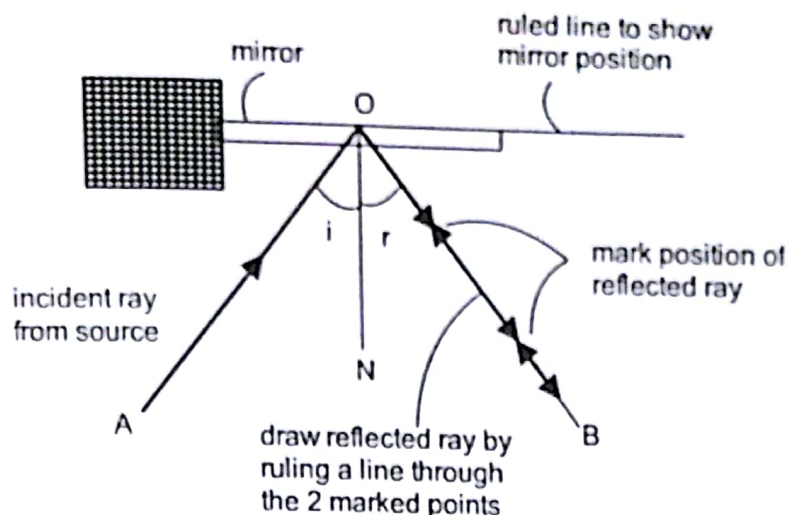

- Support a plane mirror vertically on a sheet of white paper and draw a line **ON** normal to the mirror from a point **O** near the middle of the mirror.
- Place a ray-box such that a single thin ray follows a drawn line such as **AO**.
- Mark the reflected ray **OB** with two crosses. A straight line is drawn through these two crosses to **O**.
- The angle of incidence, i and the angle of reflection, r are both measured using a protractor.
- The experiment is repeated several times for a wide range of values for i and the readings are recorded in a table shown below.

| i/degree | r/degree |
|-------------------|-------------------|
| | |

Experiment: To locate position of image in plane mirror.

Apparatus:

Mirror strip, Drawing board, Paper, Paper pins, Pencil, Protractor, ruler.

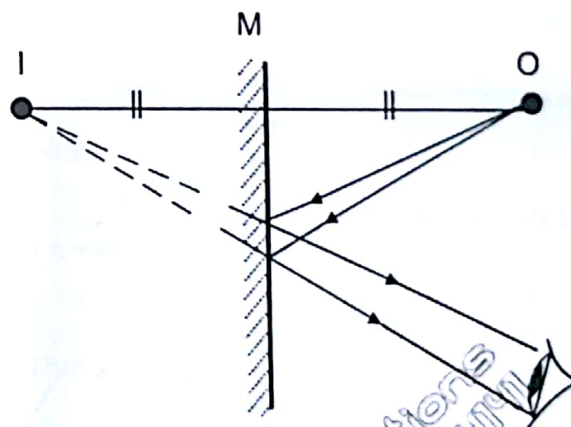

Procedure:

- Fix the paper on drawing board. Insert a paper pin **P** on paper, before the mirror strip.
- Draw two incident rays from Pin, on mirror.
- Draw the reflected rays from mirror obeying laws of reflection i.e. $i=r$.
- Extend the reflected rays backwards. The point of intersection of extended lines gives the position of image of Pin **P**.

Characteristics of Image: The image produced in plane mirror has following characteristics:

- Image size is equal to object size.
- Image distance is equal to object distance.
- Image is upright.
- Image is virtual.
- Image is laterally inverted.

REFRACTION OF LIGHT

When a ray enters from one medium to the other, then its speed as well as direction changes. This effect is called refraction of light.

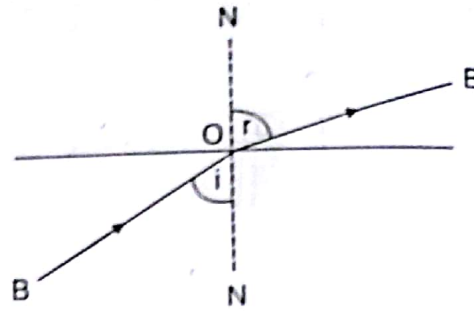

- Where AO = incident ray.
 Point O = Point of Incidence.
 NN = Normal
 OB = reflected ray.
 i = angle of incidence.
 r = angle of refraction.

Define :

- **Angle of incidence**
- **Angle of refraction**
- **Refractive index**
- **Angle of Incidence:**
The angle between the normal and incident ray.
- **Angle of Refraction:**
The angle between the normal and refracted ray.
- **Refractive Index:**
The ratio of sine of angle of incidence to sine of angle of refraction is called refractive index.

i.e.
$$n = \frac{\sin i}{\sin r}$$

Laws of Refraction:

- a) The ratio of sine of angle of incidence to sine of angle of refraction, for two specific mediums is always constant (SNELL'S LAW). i.e.

$$\frac{\sin i}{\sin r} = \text{Constant}$$

- b) The incident ray, the refracted ray and the normal, all lie in the same plane.

Effect of medium on refraction:

- When a ray enters from denser to rare (less dense) medium, it bends away from normal and speed of ray increases.

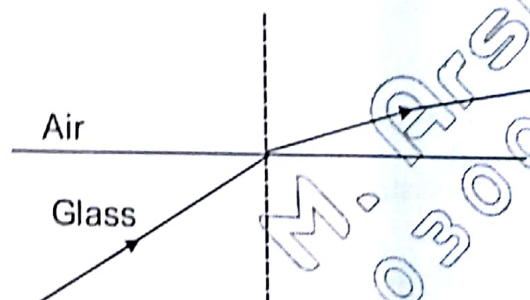

- When a ray enters from rare to denser medium, it bends towards normal and speed of ray decreases.

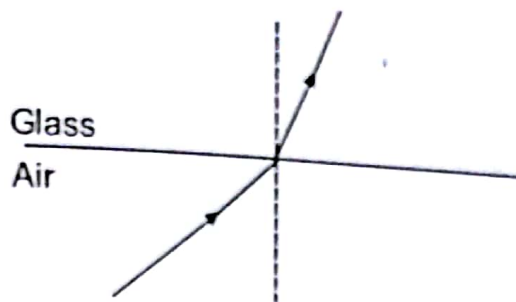

Experiment: To find refractive index $n = \frac{\sin i}{\sin r}$ of a glass block.

Apparatus: Glass block, drawing board, paper, pencil, ruler, Paper pins, Protractor.

Procedure:

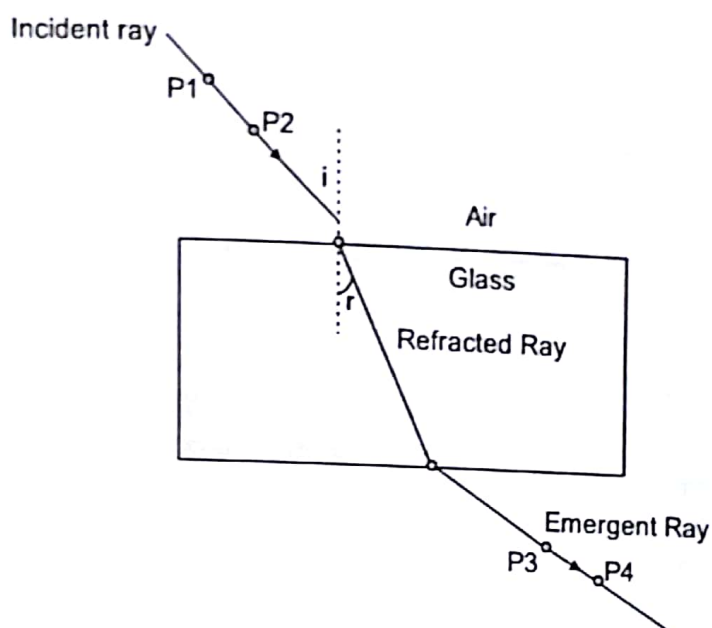

- Place the glass block on paper and mark its boundary.
- Insert 2 pins P1 and P2 on one side of glass block, making incident ray.
- Insert 2 more pins P3 and P4 on the other side of glass block, in the straight line of image of P1 and P2.
- Remove the pins and complete the Fig. by drawing incident, refracted and emergent rays.
- Measure angles i and r with protractor and use formula $n = \frac{\sin i}{\sin r}$.

CRITICAL ANGLE AND TOTAL INTERNAL REFLECTION:

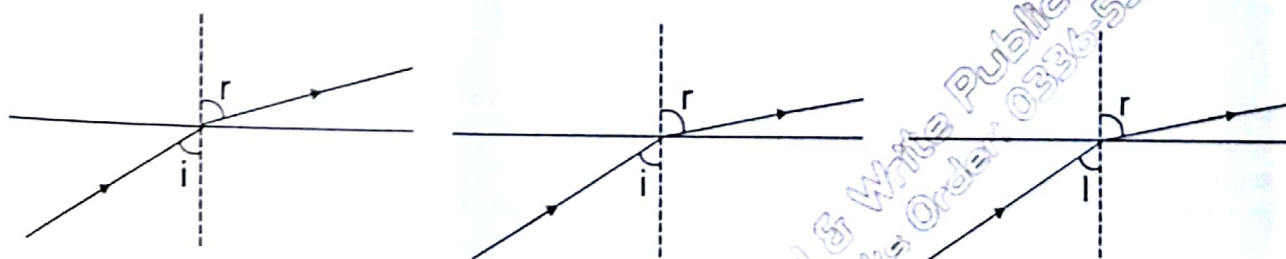

- When a ray enters from denser (glass) to rare (air) medium, it bends away from the normal. The angle of refraction in rare medium depends on the angle of incidence in denser medium. As the angle of incidence is increased, the angle of refraction keeps on increasing as shown in Figs.

- When angle of refraction in rare medium becomes 90° , then angle of incidence in denser medium is called critical angle.
i.e. $i = c$ if $r = 90^\circ$.

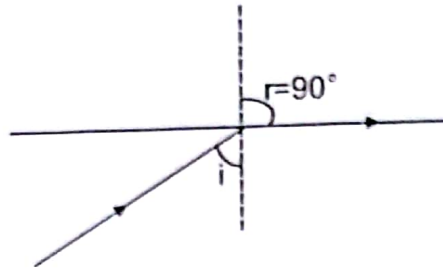

The formula for critical angle is

$$n = \frac{1}{\sin c}$$

where n = refractive index
 c = Critical angle.

For glass, value of critical angle c is 42° .

- When angle of incidence is increased beyond the critical angle, the ray bounces back in the same medium. This effect is called as total internal reflection.

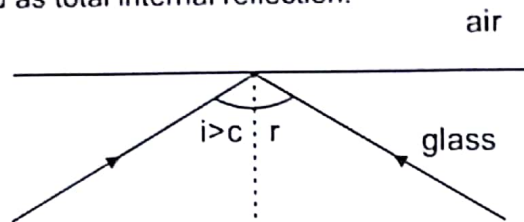

- The conditions of total internal reflection are:
 - A ray enters from denser to rare medium.
 - The angle of incidence is greater than critical angle i.e. $i > c$.

Experiment: To demonstrate the total internal refraction.

Apparatus: Ray box, semi circular glass block, paper drawing board, pencil, Protractor.

Procedure:

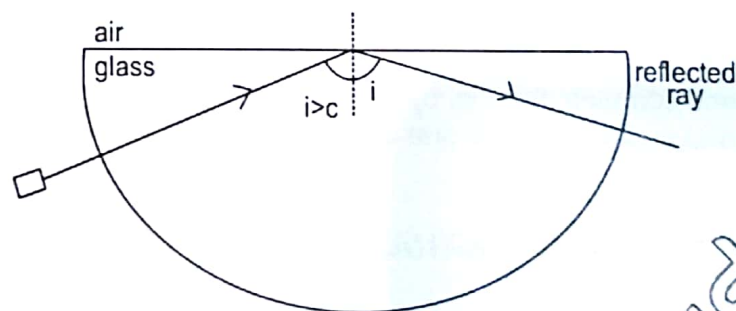

- Keep these micircular glass block on paper, fixed on drawing board.
- Fall the light ray from ray box, on the circular side of glass block.
- Keep on increasing the angle of incidence of ray, such that the ray bounces back into glass.
- The reflection of light ray from straight side of glass block shows the total internal reflection.

M. Ashraf Ch.
0300412902

APPLICATION OF TOTAL INTERNAL REFLECTION:

1) Periscope:

A periscope consists of two right angled prisms inclined in a tube. When the rays from object enter into prism, then they undergo total internal reflection, since angle of incidence ($i = 45^\circ$) is greater than critical angle ($C = 42^\circ$) of glass.

Due to total internal reflections from both the prisms, the rays emerge out from lower end of periscope to an observer, which observes the image of object. The image characteristics produced by Prism Periscope are:

- Image is upright
- Image is virtual

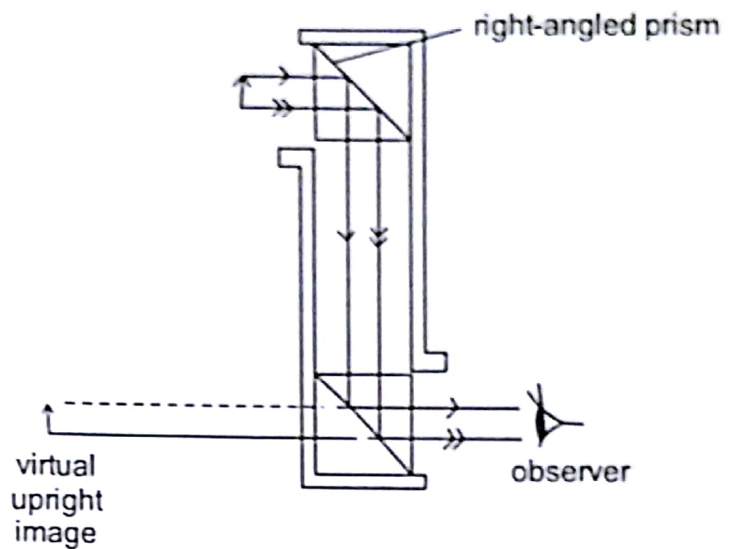

2) Optical Fibers:

The optical fiber is made up of glass or plastic of high refractive index. Light entering at one end, undergoes total internal reflections, since angle of incidence remains greater than critical angle. Even though the optical fiber may be bent, the light will still be internally reflected. Optical fibers are used for telecommunication purposes due to following advantages.

- Optical fibers carry much more information than copper wires.
- Optical fibers transfer information, at the quick rate.
- Optical fibers are cheaper than Copper wires.
- Optical fibers are very lighter, easy to handle.
- Optical fibers transfer information without any interference.

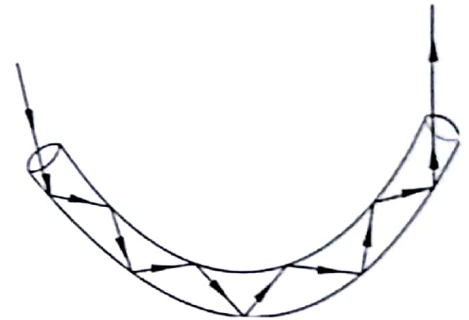

Reed & White Publications
For Books Order: 0336-531411

UNIT 13

**Lenses And
Dispersion Of
Light**

**O Level
Physics Teacher's Notes**

**M. A. Chaudhary
Cell: 0300-9412902**

Syllabus 2017 – 18**Lenses and Dispersion of Light**

- Convex and Concave lenses
- Convex lens
- Concave lens
- Image Characteristics with respect to object distance
- Linear Magnification
- Dispersion of Light
- Reason for dispersion of light
- Ultra Violet (UV) and Infra Red (IR) radiations

Unit-13 LENSES AND DISPERSION OF LIGHT

A lens is transparent curved surface, made up of glass or plastic.

CONVEX AND CONCAVE LENSES:

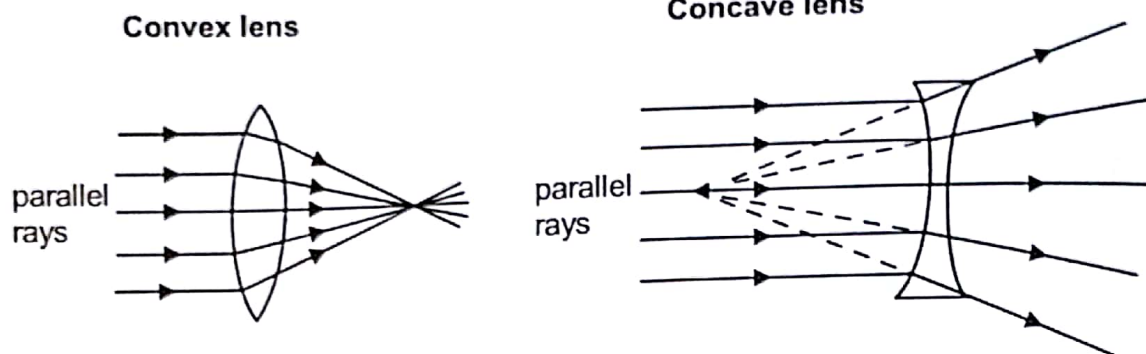

CONVEX LENS:

- It is thin at the edges and thick at the centre i.e. curved outside.
- It converges (focuses) the light rays at a point, so also called as converging lens.

CONCAVE LENS:

- It is thin at the centre and thick at the edges i.e. curved inside.
- It diverges (spreads) the light rays, so also called as diverging lens.

Basic Terms of Convex Lens:

- Optical Centre
- Principal Axis
- Principal Focus
- Focal Length
- **Optical Centre:**
It is the midpoint between the surfaces of a convex lens, through which rays pass straight.
- **Principal axis:**
A horizontal line passing through optical centre of convex lens.
- **Principal Focus:**
The point at which parallel rays falling on a convex lens focus.
- **Focal length:**
The distance between Principal focus and optical centre.

Image Formation in a convex lens:

When drawing ray diagrams, we can choose any two of the following three most important rays to enable us to find the position of the image formed by the lens.

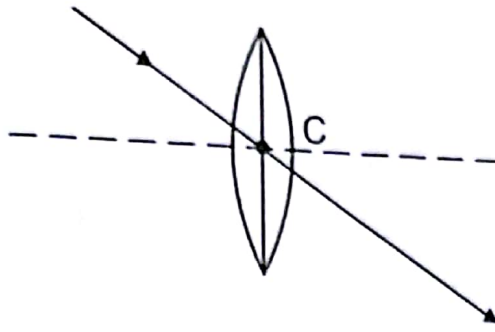

An incident ray through the optical centre C passes without bending.

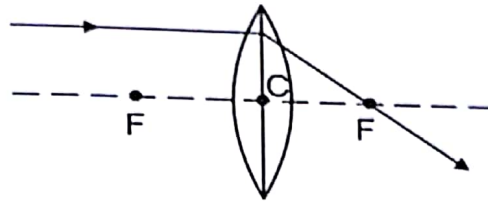

An incident ray parallel to the principal axis is refracted by the lens to pass through F.

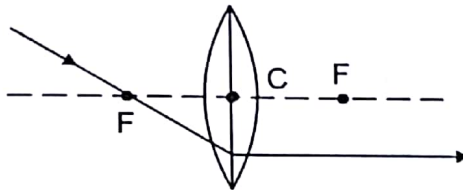

An incident ray passing through F is refracted parallel to the principal axis.

IMAGE CHARACTERISTICS WITH RESPECT TO OBJECT DISTANCE:

| Object distance (u) | Ray diagram | Type of image | Uses |
|---------------------|---|--------------------------|-------------------------------------|
| $u = \infty$ | parallel rays from a distant object | inverted real diminished | object lens of a telescope |
| $u > 2f$ | | inverted real diminished | camera; eye |
| $u = 2f$ | | inverted real same size | photocopier making equal sized copy |
| $f < u < 2f$ | | inverted real magnified | projector; photograph enlarger |

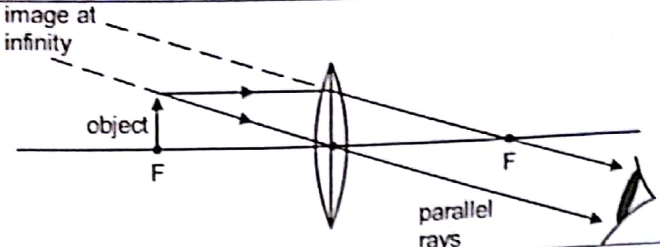
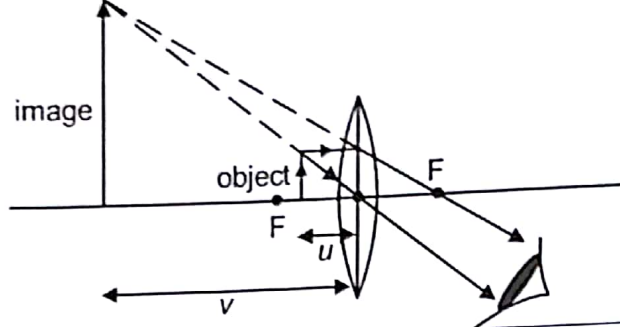
| | | | |
|---------|--|---------------------------|---|
| $u=f$ |  | upright magnified virtual | to produce parallel beam of light, as in a spot light |
| $u < f$ |  | upright magnified virtual | magnifying glass |

LINEAR MAGNIFICATION:

It is the ratio of image height to the object height.

$$\text{i.e. } m = \frac{\text{Image height}}{\text{Object height}}$$

$$\text{or } m = \frac{\text{Image distance}}{\text{Object distance}}$$

Linear magnification has no units.

Uses of Convex lens in a:

1. Magnifying glass
2. Camera
3. Projector
4. Photographic enlarger.

1. Magnifying glass:

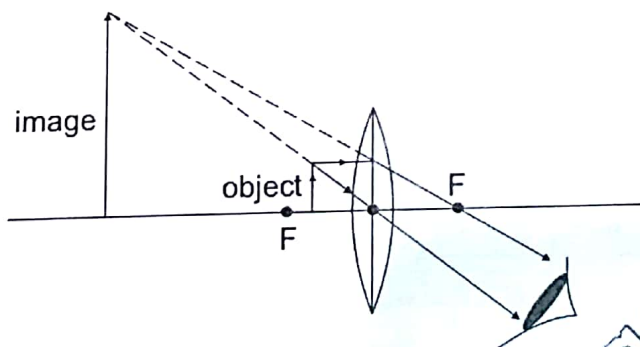

A magnifying glass is a thin converging lens. It can be used to make objects look bigger. For this purpose, object is placed from lens at a distance less than focal length. i.e. object distance $< f$. The image produced is:

- Virtual
- Upright
- Magnified
- On the same side as object.

2) Camera:

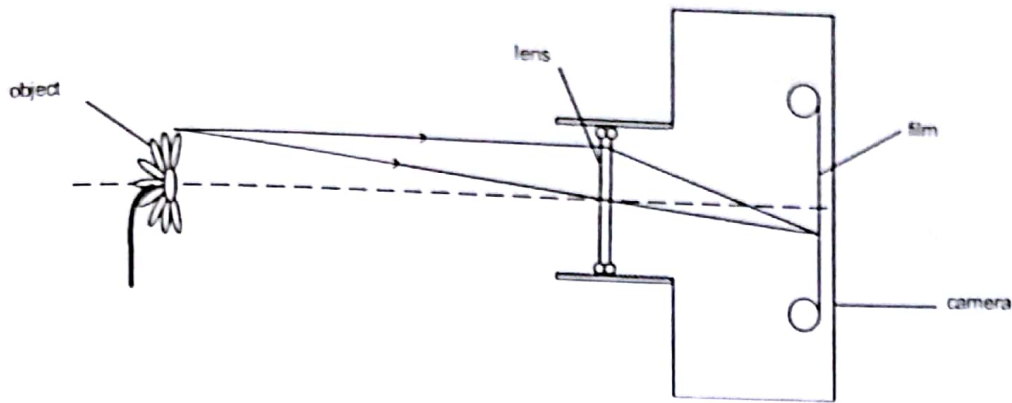

The camera uses convex lens to produce a real, inverted and diminished image on film. Focusing is done by varying the distance of the lens from film. Object distance varies from infinity to slightly larger than f .

3) Projector:

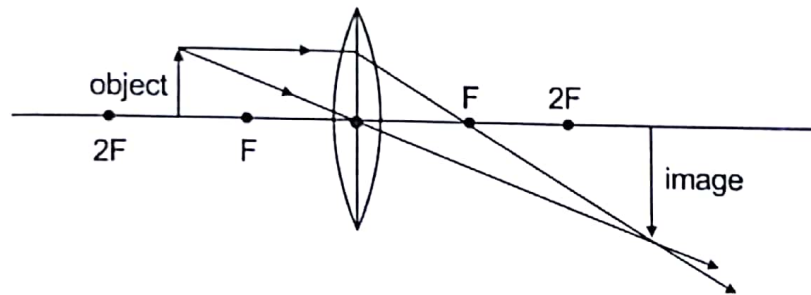

The image produced in a projector is real, inverted and magnified. Focusing of image is done by moving the convex lens so that object falls between f and $2f$. Since the image is inverted both vertically and laterally, hence the slide is placed upside down and flipped 180° , so that the image will be projected right way.

4) Photographic enlarger:

The working principle of a photograph enlarger is basically the same as that of projector. The film in a photograph enlarger is placed between f and $2f$ of the focusing lens. The image produced is

- Real
- Inverted
- Magnified

The ray diagram is same, as shown in the working of projector.

Image formation in Eye:

Like a camera, the eye uses a convex lens system to produce real, inverted and diminished image of an object. The 'screen' in this case is called retina.

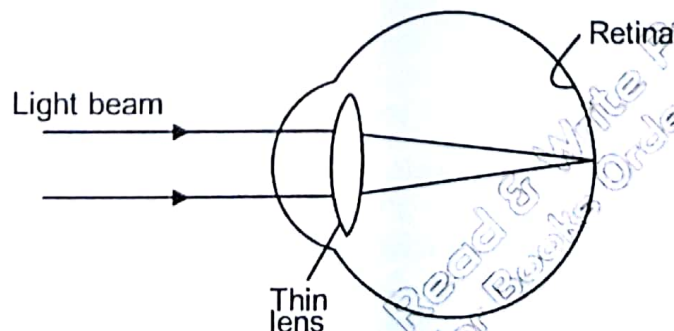

Short-sighted Eye:

A short-sighted person can see near objects clearly but not far objects. In short-sightedness, the focal length of lens is too small, such that the rays focus before reaching the screen. So image produced is not clear. This effect can be removed by using a concave lens in front of eye.

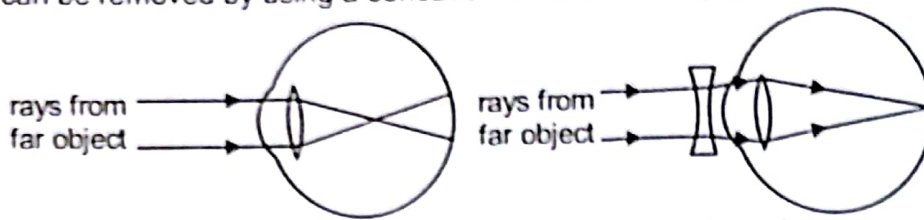
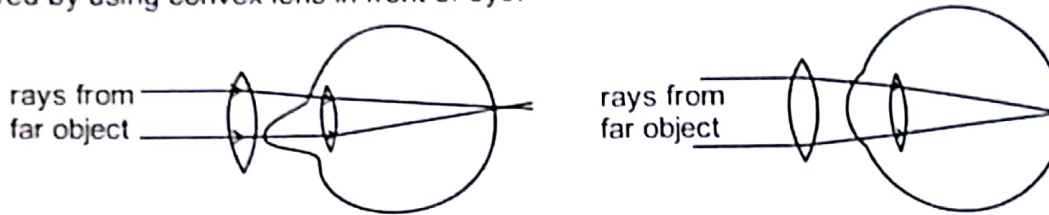

Fig: Short -sightedness

Fig: Removal of short sightedness

Long-sighted Eye:

A long-sighted person cannot see close objects clearly. In long-sightedness, the focal length of lens is too large, such that rays tend to focus, after the screen. Again image is not clear but it is blurred. This effect can be removed by using convex lens in front of eye.

**DISPERSION OF LIGHT**

Dispersion of light is the splitting up of a light beam into its component colours.

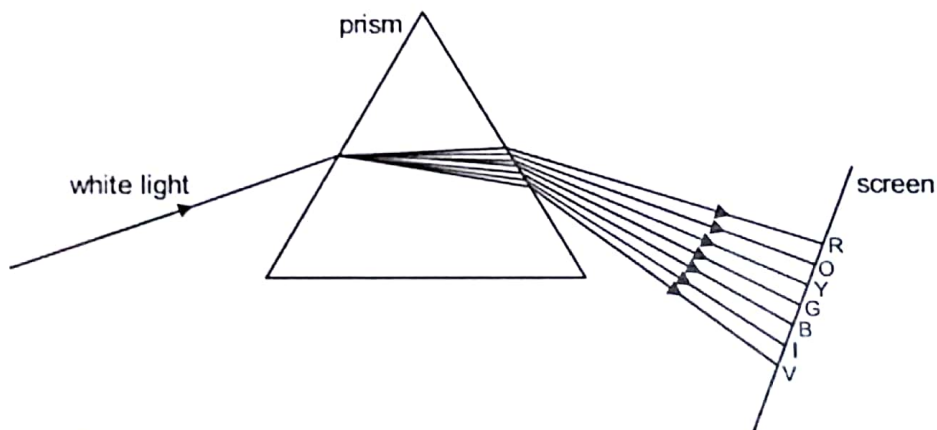
**The colours produced are:**

- V – Violet
- I – Indigo
- B – Blue
- G – Green
- Y – Yellow
- O – Orange
- R – Red

The main features of dispersion of light through a prism are:

- The colour range produced is called spectrum.
- The red light is deviated least and violet light is deviated most.
- The deviation for each colour is always towards base of the prism.
- Each colour travels with speed of light.
- The wavelength increases from violet towards red colour.
i.e. shortest wavelength = violet colour
 Longest wavelength = red colour

- The frequency increases from red towards violet colour.
i.e. least frequency = red colour
Maximum frequency = violet colour

REASON FOR DISPERSION OF LIGHT:

The white light consists of seven radiations each having different wave-length. The speed of light through the glass prism is different for different wavelengths. Due to difference in speed, each wavelength bends differently passing through a glass prism and spectrum of colours is produced.

ULTRA VIOLET (UV) AND INFRA RED (IR) RADIATIONS:

UV:

Beyond the violet end of spectrum is the invisible UV-radiations. These radiations can be detected by:

- Blackening of photographic film.
- Fluorescence e.g. currency notes usually have certain marks, which glow under UV-lamps.

IR:

Beyond the red colour of visible spectrum is the invisible IR radiation. These radiations can be detected by

Thermopile i.e. galvanometer deflects by sensing the IR-radiations.

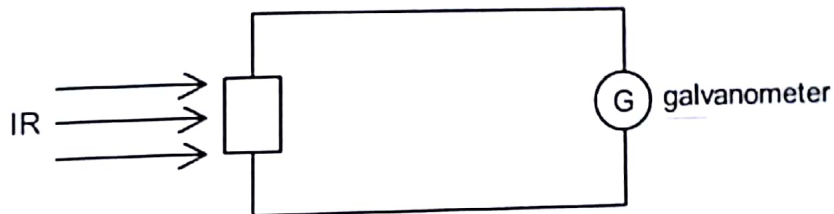

- By placing thermometer, since IR radiations cause heating effect.

Reed & White Publications
For Books Order: 0336-531411

UNIT 14

Waves

O Level

Physics Teacher's Notes

M. A. Chaudhary

Cell: 0300-9412902

Syllabus 2017 – 18

Waves

- Transverse wave
- Longitudinal wave
- Basic Terms of waves
- Ripple Tank
- Observations and Conclusions
- Electromagnetic waves
- Common Characteristic of electromagnetic waves
- Origin and Detection of Electromagnetic Waves
- Specific properties of Electromagnetic Waves
- Uses of Electromagnetic Waves

Unit-14 WAVES

WAVES

Waves are mechanism by which transfer of energy occurs, without transfer of matter.

TRANSVERSE WAVE:

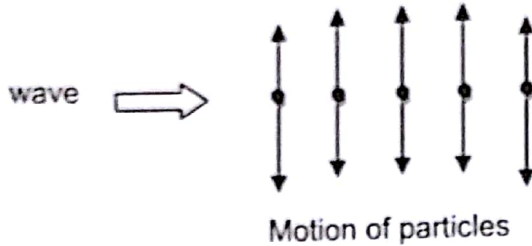

If particles of medium vibrate up and down or perpendicular to wave direction then such a wave is called transverse. e.g. water waves, waves on rope or string, electromagnetic waves.

LONGITUDINAL WAVE:

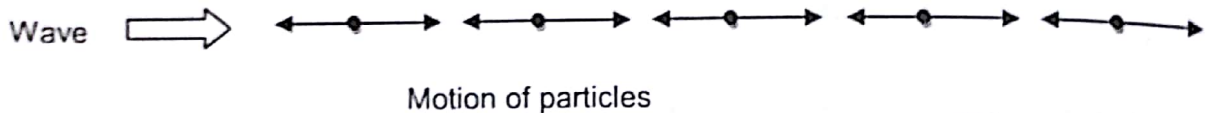

If particles of medium vibrate horizontally or parallel to wave direction then such a wave is called longitudinal e.g. sound waves, waves on a slinky spring.

BASIC TERMS OF WAVES:

1. Crest and trough
2. Amplitude
3. Wavelength
4. Time period
5. Frequency
6. Phase
7. Wave front
8. Wave speed

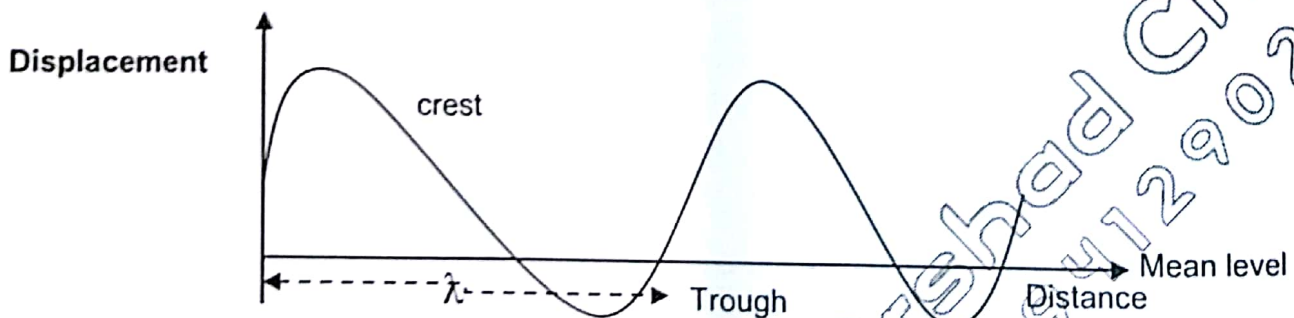

M. Arshad Ch.
0300-912902

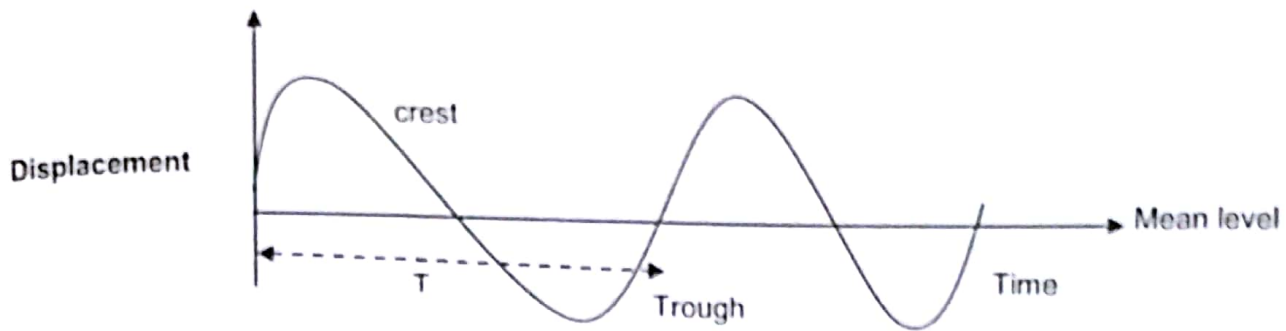

1) Crest and Trough:

The part of a wave above the mean level is Crest and below the mean level is trough.

2) Amplitude(a):

The max. displacement above or below the mean level.

3) Wavelength (λ):

The distance between two consecutive crests or troughs.

4) Time Period (T):

Time required to complete one cycle of a wave.

5) Frequency (f):

Frequency is number of cycles per second. It is equal to reciprocal of time period. i.e.

$$f = \frac{1}{T}$$

S.I unit of frequency is Hertz (Hz).

6) Phase:

The points on a wave are in phase if they are at the same displacement and moving in the same direction.

7) Wave front:

A wave front is an imaginary line on a wave that joins all points which are in the same phase.

8) Wave Speed (V):

Distance moved by a wave per unit time is called wave speed.

The wave speed (V), frequency (f) and wavelength (λ) are related by wave equation.

$$V = f\lambda$$

Where V = wave speed measured in ms^{-1} .

f = frequency measured in Hz.

λ = wavelength measured in m.

Read & Write Publications
For Books Order: 0334-5314111

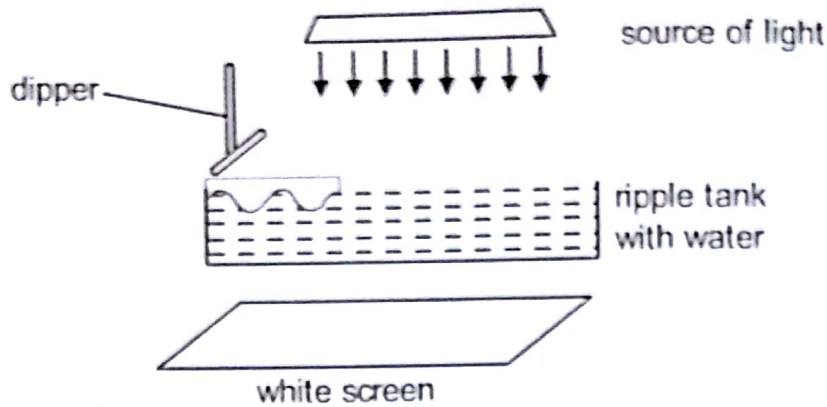
RIPPLE TANK:

The main parts of ripple tank are:

- **Glass tank** Containing water.
- **Vibrator** which is used to produce water waves.
- **Lamp** which is used to illuminate water waves.
- **Screen** which is used to obtain image of water waves.

OBSERVATIONS AND CONCLUSIONS:

a) **To study that water waves are transverse:**

Keep the piece of paper on the surface of water in tank. Produce water waves with vibrator. The piece of paper vibrates up and down on its fixed position, showing that water waves are transverse.

b) **To study reflection of water waves:**

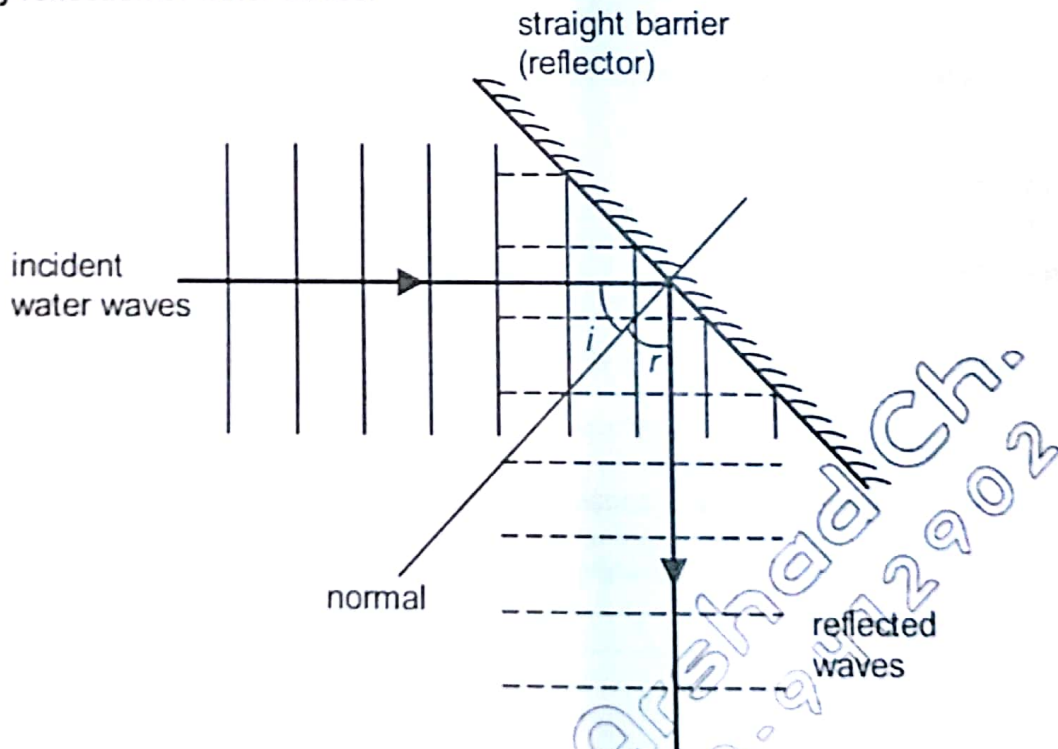

Place a straight barrier upright in water. Produce water waves with vibrator. The water waves are reflected from barrier obeying laws of reflection, i.e. $i = r$

c) To study refraction of water waves:

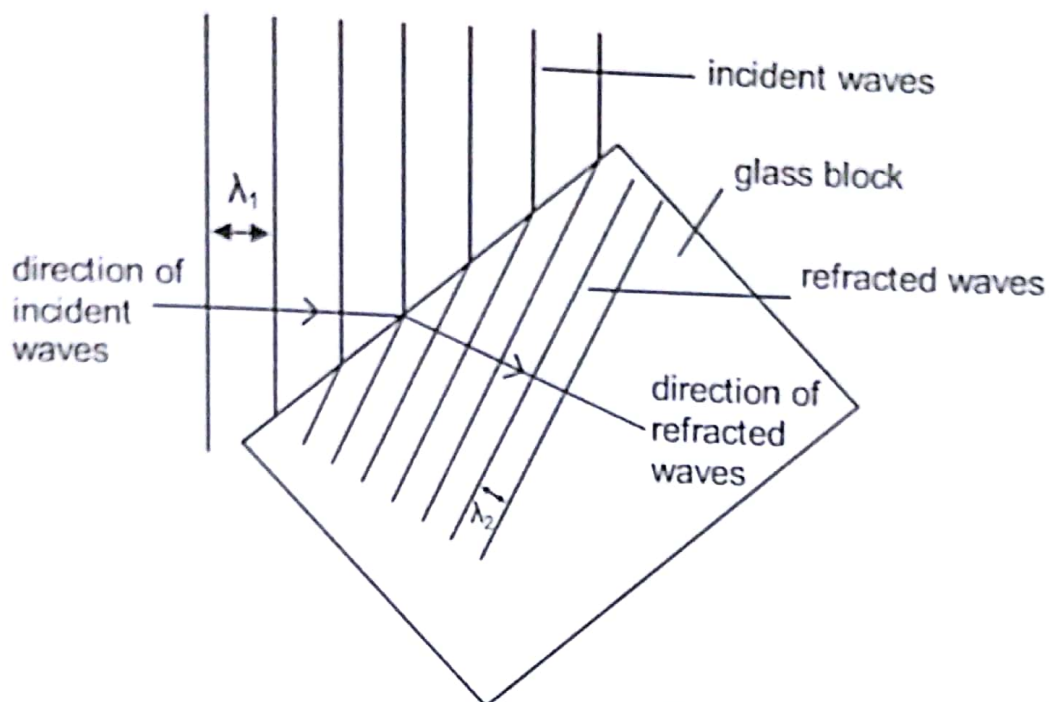

First make water deep and shallow by keeping glass block inside tank. When waves enter from deep → shallow water then:

- > Frequency (f) remains same. i.e. $f_2 = f_1$.
- > Wavelength (λ) decreases i.e. $\lambda_2 < \lambda_1$.
- > Speed (V) decreases i.e. $V_2 < V_1$.

The refractive index is calculated by the formula:

$$n = \frac{\lambda_2}{\lambda_1} \text{ or } \frac{V_2}{V_1}$$

Where λ_1 = wavelength in deep water.

λ_2 = wavelength in shallow water.

V_1 = speed in deep water.

V_2 = speed in shallow water.

ELECTROMAGNETIC WAVES:

The main components of electromagnetic spectrum are:

1. γ - Gamma rays
2. X - rays
3. UV - Ultraviolet rays
4. Light rays
5. IR - Infra red rays.
6. Micro - micro waves.
7. Radio - radio waves.

The arrangement of electromagnetic waves is shown below:

| | | | | | | |
|----------|---|----|-------|----|-------|-------|
| γ | X | UV | Light | IR | Micro | Radio |
|----------|---|----|-------|----|-------|-------|

- λ_{\max} is for radio waves and λ_{\min} is for γ rays. i.e. wavelength λ increases from $\gamma \rightarrow$ radio waves.
- f_{\max} is for γ rays and f_{\min} is for radio waves. i.e. frequency f decreases from $\gamma \rightarrow$ radio waves.

COMMON CHARACTERISTIC OF ELECTROMAGNETIC WAVES:

- They are all transverse.
- They can pass through vacuum.
- They travel at the speed of light i.e. $3 \times 10^8 \text{ ms}^{-1}$.
- They do not carry any charge.
- They are not effected by electric and magnetic fields.
- They transfer energy from one place to another.
- They obey laws of reflection and refraction.

ORIGIN AND DETECTION OF ELECTROMAGNETIC WAVES:

| Waves | Origin | Detectors |
|-------|--|---|
| Y | <ul style="list-style-type: none"> • Radioactive nuclei. • Cosmic rays. | <ul style="list-style-type: none"> • Photographic film • Geiger – Muller (GM) tube. |
| X | X-ray tubes | <ul style="list-style-type: none"> • Photographic film • Fluorescent screen. |
| UV | <ul style="list-style-type: none"> • Sun • Mercury vapour lamps. | <ul style="list-style-type: none"> • Photographic film • Fluorescent chemicals. |
| Light | <ul style="list-style-type: none"> • Sun • Lamps & lasers | <ul style="list-style-type: none"> • Photographic film • Photocells |
| IR | <ul style="list-style-type: none"> • Sun • Hot objects | <ul style="list-style-type: none"> • Photographic film • LDR |
| Micro | <ul style="list-style-type: none"> • Microwave ovens • TV and radio transmitters | <ul style="list-style-type: none"> • Aerials • Microwave receivers |
| Radio | <ul style="list-style-type: none"> • Radio and TV transmitters | <ul style="list-style-type: none"> • Aerials connected to tuned electric circuits in radio and T.V sets. |

SPECIFIC PROPERTIES OF ELECTROMAGNETIC WAVES:

| Waves | Specific Properties |
|-------------|---|
| Y | <ol style="list-style-type: none"> 1) Very penetrating. 2) Very dangerous. 3) Ionize gases. |
| X | <ol style="list-style-type: none"> 1) Very penetrating. 2) Ionize gases. 3) Cause fluorescence. |
| UV | <ol style="list-style-type: none"> 1) Cause many chemical reactions. 2) Absorbed by glass. 3) Ionize gases. |
| Light | <ol style="list-style-type: none"> 1) Can cause chemical reactions. 2) Refracted by glass. |
| IR | <ol style="list-style-type: none"> 1) Cause heating effect 2) Less scattered so used for photography through haze and fog. |
| Microwaves | <ol style="list-style-type: none"> 1) Spread around hills and buildings by diffraction. 2) Cause high vibration of atoms so used for heating purposes in microwave ovens. |
| Radio waves | <ol style="list-style-type: none"> 1) Have very high wavelengths 2) Due to high wavelengths used for radio and TV signals. |

USES OF ELECTROMAGNETIC WAVES:

| Waves | Uses |
|-------|--|
| Y | <ol style="list-style-type: none"> 1. γ -rays can be used to kill cancer cells and to destroy brain tumors. 2. γ - rays are used to sterilize surgical equipments. 3. γ - rays are used to find flaws in metal. |
| X | <ol style="list-style-type: none"> 1. X - rays are used to detect fractures in bones. 2. X - rays are used as scanners in airports. 3. X - rays are used to study arrangement of atoms in crystals. |
| UV | <ol style="list-style-type: none"> 1. UV lamps are used in sunbeds for artificial tanning. 2. UV causes fluorescence which is used in washing powders. 3. UV are used for checking counterfeit notes and forgeries. |
| Light | <ol style="list-style-type: none"> 1. Light is used in optical fibers for telecommunications. 2. Light is used to make the things visible. 3. Light is used for photosynthesis process. |
| IR | <ol style="list-style-type: none"> 1. IR is used in remote controls. 2. IR is used in burglar alarm systems. 3. IR is used in mobile phones. |
| Micro | <ol style="list-style-type: none"> 1. Micro waves are used in microwave ovens for heating and cooking purpose. 2. Micro waves are used in satellite - televisions. 3. Microwaves are used for radar detection of ships, aircrafts and missiles. |
| Radio | <p>Radio waves are used in radio broadcasting, wireless telegraphy, telephone transmission, TV, radar and navigation systems.</p> |

Read & Write Publications
For Books Order: 0334-531411

UNIT 15

Sound

**O Level
Physics Teacher's Notes**

**M. A. Chaudhary
Cell: 0300-9412902**

Syllabus 2017 – 18

Sound

- Basic Concepts
- Experiment to determine speed of sound in air
- Loudness, pitch and Quality (timbre) of sound
- Ultrasound

Unit-15 SOUND

BASIC CONCEPTS:

- Sound is a form of energy, which is transferred from one point to other in the form of waves.
- Sound is produced due to vibration.
- Sound waves travel in the form of compressions and rarefactions e.g. the vibrating prongs of the tuning fork compress and rarefy the air molecules and sound waves are sent out.

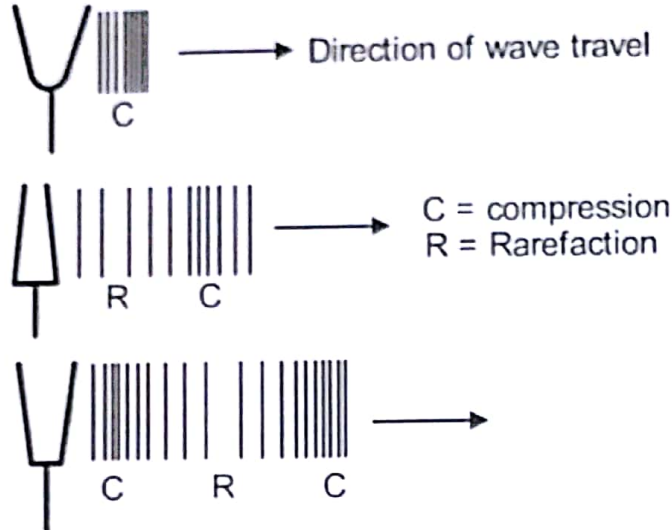

- A compression in a sound wave is the region in which the molecules of medium are closer. A rarefaction is a region in which the molecules of medium are further apart.
- Since compressions and rarefactions travel horizontally or parallel to direction of sound wave, so sound waves are longitudinal.

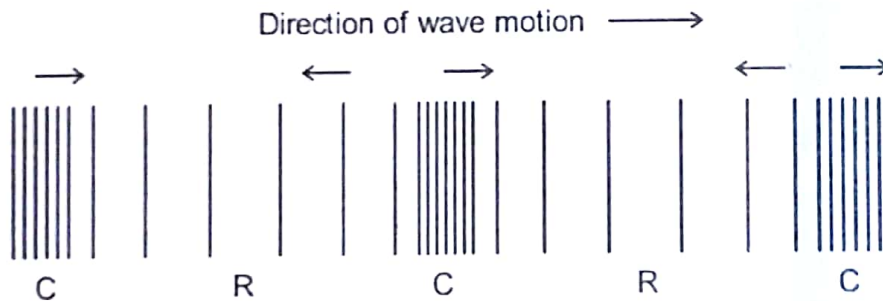

- The wavelength of a sound wave or longitudinal wave is the distance between the centers of two consecutive compressions of the wave.

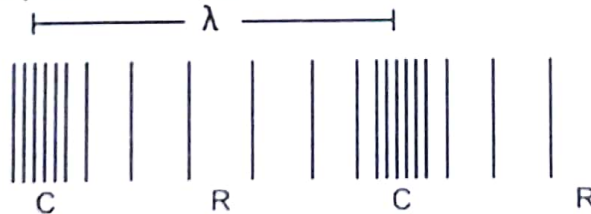

To demonstrate that medium is required for transmission of sound.

Sound waves require a medium in order to travel from one point to other. Since sound waves travel in the form of compressions and rarefactions, if there is vacuum, then no compressions and rarefactions are produced and sound energy is not transferred.

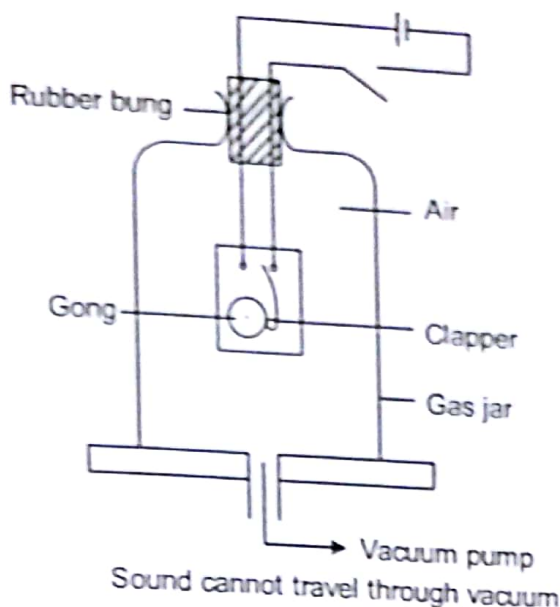

Fix an electric bell in a glass jar. When current is passed, the ringing bell is heard. The air in the glass jar is gradually pumped out with vacuum pump. The sound slowly becomes softer. When air is completely pumped out, no sound is heard from the ringing bell.

Speed of sound in different mediums:

The nature of medium effect the speed of sound. The speed of sound depends on the density of medium i.e. denser is the medium, higher is the speed of sound and vice versa. The approximate values of speed of sound in different mediums are:

| Medium | Approx. speed |
|---------|-----------------------|
| Gases | 300 ms ⁻¹ |
| Liquids | 1500 ms ⁻¹ |
| Solids | 5000 ms ⁻¹ |

Factors effecting speed of sound in air:

| Factors | Effect on speed of sound in air |
|-------------|--|
| Temperature | Speed of sound increases with rise of temperature. |
| Density | Sound travels faster in denser medium. |
| Humidity | Sound travels faster when humidity rises. |

Audible Frequency Range:

The range of frequencies which a listener can hear is the audible frequency range. A normal person can hear the sound having frequency between 20Hz → 20000Hz (20KHz). A sound with a frequency less than 20Hz is called **infrasound** and above 20000 Hz is called **ultrasound**. Both ultrasound as well as infrasound are non-audible.

EXPERIMENT TO DETERMINE SPEED OF SOUND IN AIR

Apparatus: Measuring tape, gun and stopwatch.



Procedure:

- Mark two positions A and B, at a distance d apart from each other.
- At point A, person fires the gun.
- At point B, person notes the time between observing the gun flash and listening the sound.

Observations & Calculations:

Distance between positions A and B = d

Time interval between flash and sound = t

$$\therefore \text{speed of sound} = \frac{\text{distance}}{\text{time}}$$

$$\text{Or } V = \frac{d}{t} = 330 \text{ ms}^{-1}.$$

Precautions:

- > Repeat the experiment and take average value for more accuracy.
- > In order to avoid error due to wind direction exchange positions of persons A and B and repeat the experiment.

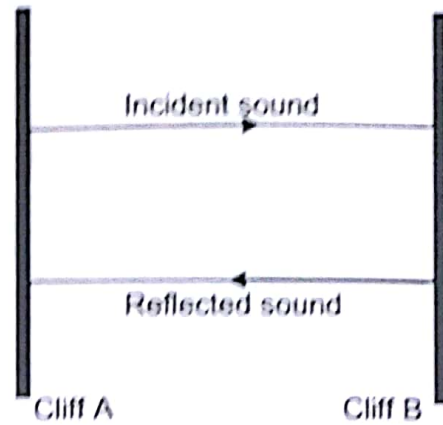
**Reflection of Sound – Echo:**

When sound is incident on a big surface area, the part of sound energy is reflected. The reflected sound waves heard after a silence, is called an echo.

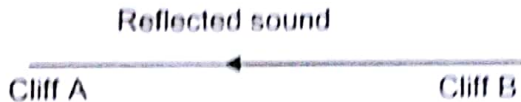

Suppose a person claps near cliff A. The sound is reflected back from cliff B and an echo is produced. The distance between cliffs is d .

For an echo, total distance travelled by sound = $d+d = 2d$.

$$\therefore \text{Speed of sound} = \frac{\text{distance}}{\text{time}}$$

$$\text{Or } V = \frac{2d}{t}$$

Applications of Echo:

There are many uses of echoes. The applications of echoes include the measuring of large distances or the detection of the location of objects that are not easily sighted.

M. Arshad Ch.
0300-9412902

For example, by sending out a signal (a pulse of sound) and noting the time interval before the reflected signal (echo) arrives, the depth of the sea or even the position of shoals of fish (Figure) can be found. For military purposes, echo-sounding is used to detect the position of mines and submarines.

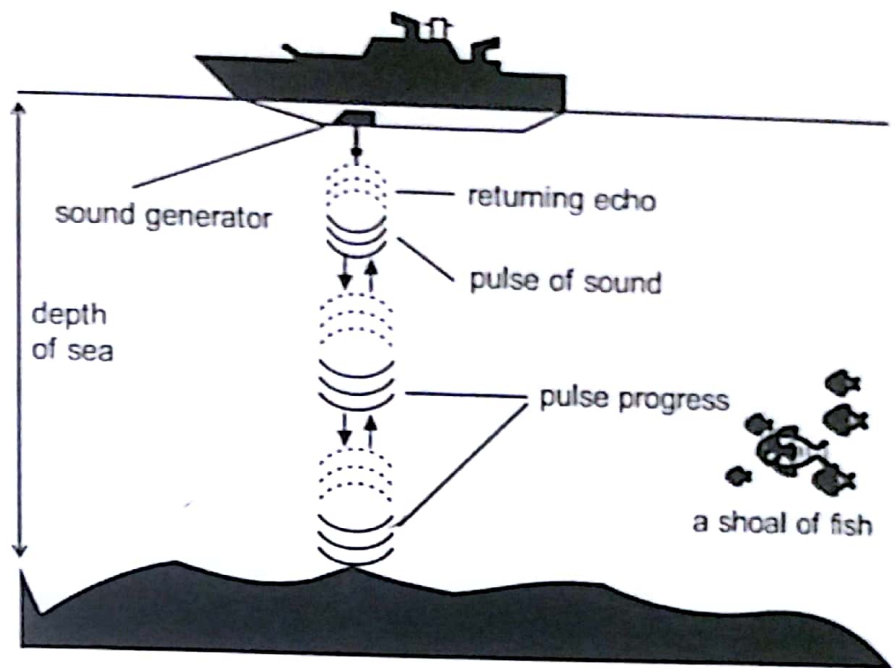

Among animals, bats are known to use echoes to detect the presence of obstacles during flight. They emit a high frequency sound or ultrasound that is reflected off objects in their path. The echo is heard by the bats which can then pinpoint the position of obstacles and thus avoid them.

LOUDNESS, PITCH AND QUALITY (TIMBRE) OF SOUND.

- **Loudness :**

If the energy carried by a sound wave is larger, then sound is louder and vice versa. Loudness depends on amplitude, the larger is the amplitude, the louder is the sound and vice versa.

- **Pitch:**

Pitch determines the sharpness of sound. It depends on frequency of sound wave. Higher is the frequency, more sharp is the sound and higher is the pitch and vice versa.

- **Quality (timbre):**

The combined effect of different sound waves determines the timbre of sound. When sounds of higher frequencies are added to the fundamental frequency of an instrument, then different waveforms are produced as shown in figs.

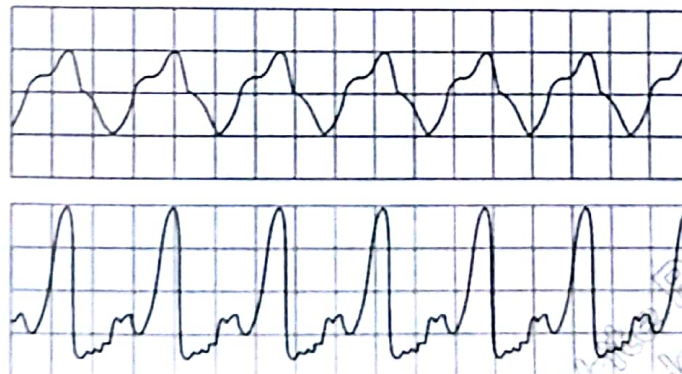

The timbre or quality of sound depends on:

- Waveform of sound wave.
- Fundamental frequency of sound.
- Higher frequencies, called as harmonics.

Read & Write Publications
For Books Order: 0336-531411

ULTRASOUND:

Ultrasound is sound waves with frequency greater than 20000Hz. Ultrasound is inaudible to humans. Ultrasound is used for:

1. Pre-natal scanning:

Ultrasound can be used to obtain images of the internal parts of body. Ultrasound pulses are sent into body by means of a transmitter. The echoes reflected from any surfaces help in pre-natal examination to examine the development of the foetus.

2. Cleaning:

The transmission of high ultrasound may result in the creation of cavitation bubbles, due to rarefactions. These cavitation bubbles may displace contaminant from irregular surfaces or internal cavities.

3. Quality control:

Due to excessive use cracks appear in the interior of the moving parts of high speed heavy machines such as turbines, engines of ships and aero planes. These cracks are not visible from outside. Such cracks can be detected by ultrasound. A powerful beam of ultrasound is made to pass through these defective parts. The reflected pulses of ultrasound from defective parts can give a clue of the existence of the cracks.

M. Arshad Ch.
0300-9412902

UNIT 16

**Static
Electricity**

**O Level
Physics Teacher's Notes**

**M. A. Chaudhary
Cell: 0300-9412902**

Syllabus 2017 – 18**Static Electricity**

- Basic Concepts
- Charging by Friction
- Electrostatic Induction
- Earthing
- Charging an object by Earthing
- Electric Field
- Applications of Static Energy
- Electrostatic Precipitator

Unit-16 STATIC ELECTRICITY

BASIC CONCEPTS:

- > There are two types of charged particles i.e. electrons which carry negative charges and protons which carry positive charge.
- > If number of electrons on an object are larger than number of protons then that object carries negative charge i.e. gain of electrons mean negative charges.
- > If number of electrons on an object are less than number of protons then that object carries positive charge i.e. loss of electrons mean positive charges.
- > Like charges repel one another and unlike charges attract one another.
- > The SI unit of charge is Coulomb (C). The charge on an electron or proton is 1.6×10^{-19} C i.e. 6.25×10^{18} electrons or protons make one coulomb charge.
- > Conductors are substances that have free electrons, and are able to conduct electricity e.g. metals like silver, copper and iron etc.
- > Insulators are substances that do not have free electrons, and thus cannot conduct electricity e.g. glass, plastic and wood etc.

CHARGING BY FRICTION:

Due to rubbing of two objects, heating effect is produced by friction. The electrons gain energy and may shift from one object to the other.

- The object from which electrons are shifted carries positive charge.
 - The object on which electrons are shifted carries negative charge.
- The experimental results of charges by friction are given in the table below.

| Materials | Positive Charge | Negative Charge |
|------------------------------------|-----------------|-----------------|
| Glass rod rubbed with silk | Glass | Silk |
| Ebonite rod rubbed with fur | Fur | Ebonite |
| Plastic comb rubbed with hair | Hair | Comb |
| Perspex ruler rubbed with duster | Perspex | Duster |
| Polythene strip rubbed with duster | Duster | Polythene |

ELECTROSTATIC INDUCTION:

"When a charged object is brought near a neutral one, then positive and negative charges on neutral object are separated. This effect is called electrostatic induction."

Explanation:

Step 1: Rub the ebonite rod with fur to make the rod negatively charged.

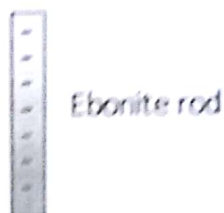

Step 2: Keep the two metal spheres in contact with each other on insulating stands.

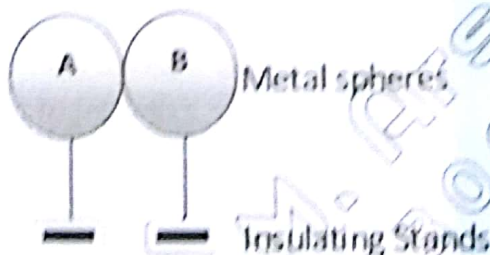

Step 3: Place the negatively charged rod near sphere A. This causes the electrons from A to be repelled to right most of sphere B, leaving positive charges there.

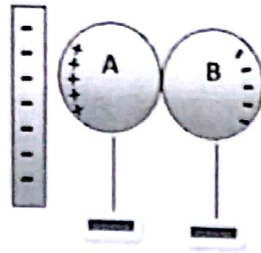

Step 4: With the negatively charged rod in place, the two spheres are separated.

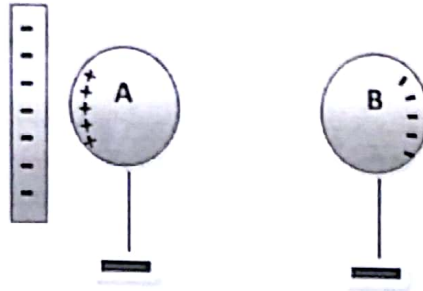

Step 5: Now remove the negatively charged rod from spheres. The net charge on sphere A is positive and on B is negative. Such charges are called induced charges and the process to separate positive and negative charges is called electrostatic induction.

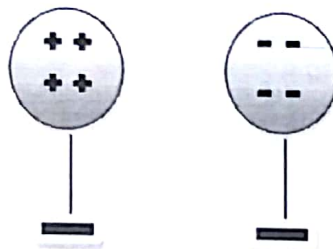

EARTHING:

This is process by which electrons flow to or from the earth. For an example, a lightning conductor can serve as an earth for lightning. The symbol for earth is:

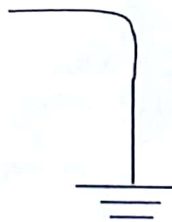

CHARGING AN OBJECT BY EARTHING:

a) To make an object positively charged:

Step 1: Keep the negatively charged rod near a neutral sphere. The positive and negative charges are induced on the sphere.

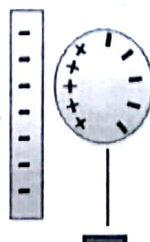

Step 2: Earth the negative side of sphere. The electrons move out from sphere to earth, leaving positive charges on sphere.

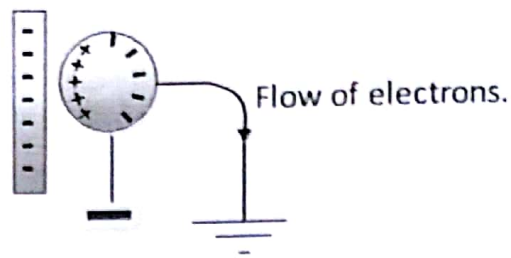

Step 3: Disconnect the earth connection and remove the rod away from sphere. The net charge on sphere remains positive.



b) To make an object negatively charged:

Keep a positively charged glass rod near a neutral sphere. The negative and positive charges are induced on sphere. Earth the positive side of sphere. The electrons flow from earth on the sphere, to neutralize positive charges. Disconnect the earth connection and remove the rod away from sphere. The net charge on sphere remains negative.

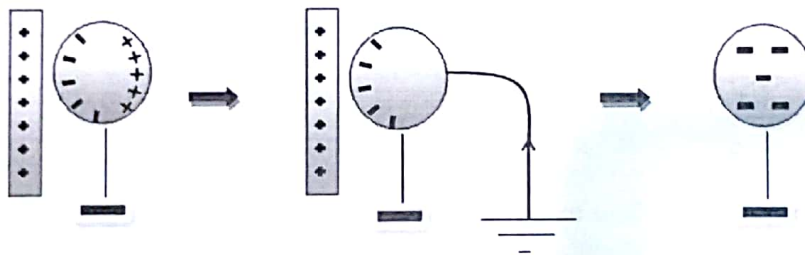

ELECTRIC FIELD

"It is region in which an electric charge experiences a force."

The electric field lines are used to represent the direction of an electric field, which have following characteristics.

- > Electric field lines start from positive charge and end on negative charge.
- > Electric field lines do not intersect each other.
- > The closer the field lines, the stronger is the electric field in that region and vice versa.
- > The equally spaced lines represent uniform electric field.
- > The lines between two like charges repel each other, and a neutral point is produced between charges.

M. Arslan
0300-941

Electric Field Patterns:

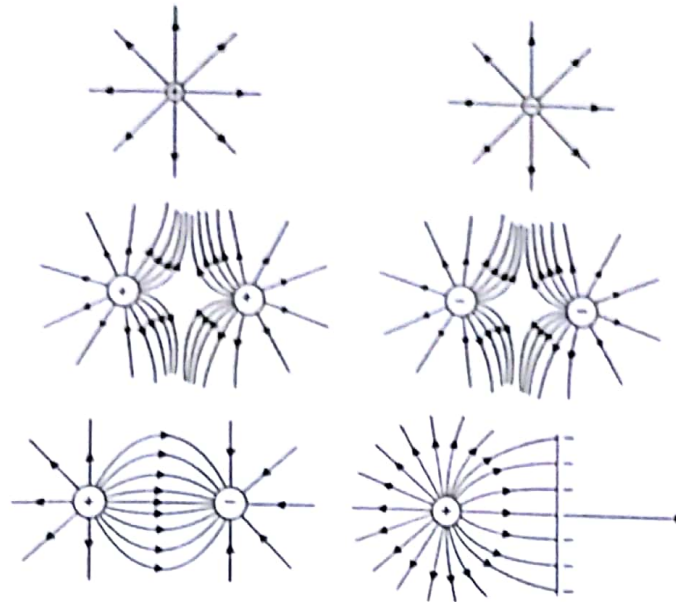

APPLICATIONS OF STATIC ENERGY

- Electrostatic Precipitator
- Electrostatic Spray Painting
- Lightning
- Photocopier

ELECTROSTATIC PRECIPITATOR

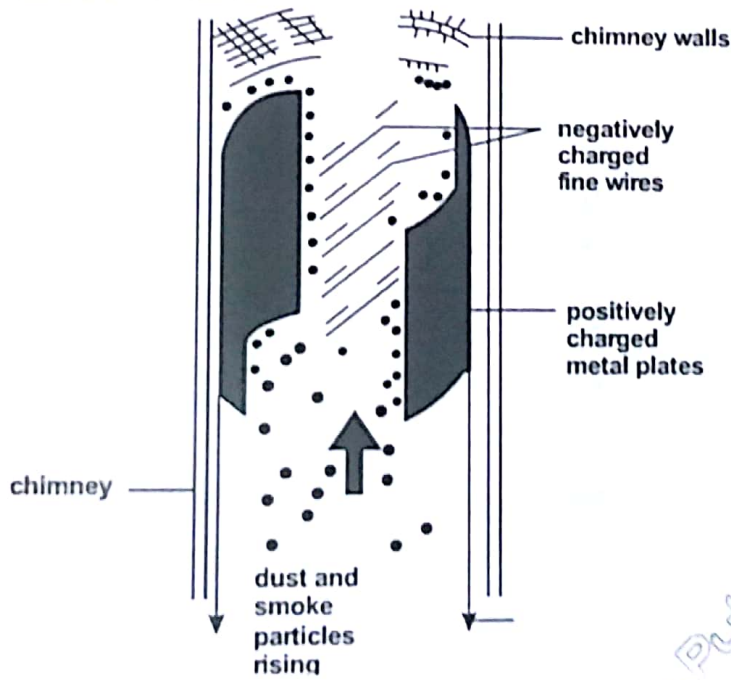

At the bottom of chimney, the temperature is higher. The dust and ash particles rise upwards along with hot gases. The dust and ash particles acquire negative charge, as these are passed through negatively charged wire gauze. The negatively charged particles are thus collected by positive plates due to attraction. The plates are then mechanically shaken to remove the ash which is collected. In this way air pollution into the atmosphere is minimized by using electrostatic precipitator.

Revised Edition Publications
For Example: 0336-531111

Electrostatic Spray Painting

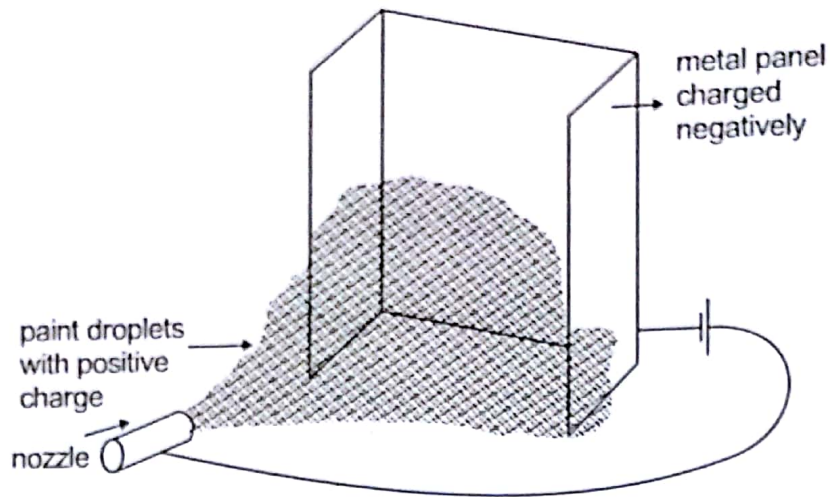

The metal panel is charged negatively and paint droplets are given a positive charge. The droplets spread out as they leave the nozzle, because of repulsion between them. The negatively charged metal panel attracts all the paint droplets towards it, producing a layer of paint.

The advantages of electrostatic spray painting are:

- This method produces uniform layer of paint.
- This method is effective, efficient and economical.

Lightening

Thunderclouds contain charges. The charges are produced due to friction between the water molecules in the thunderclouds and the air molecules.

When the charge on thunderclouds is sufficiently large, then it is discharged towards building or ground.

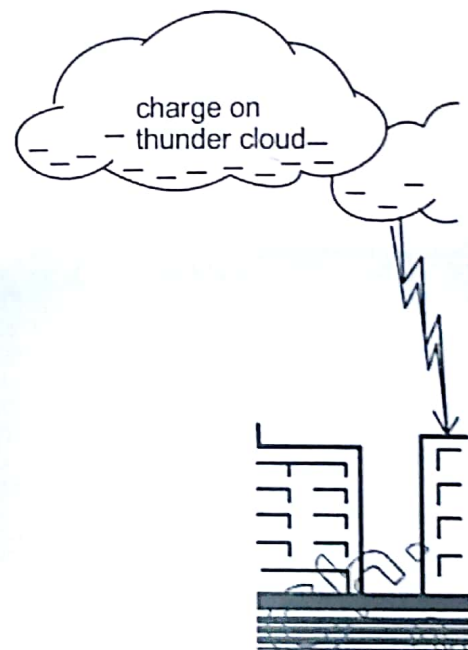

To prevent lightening from damaging tall buildings lightning conductors are used. The lightning conductors provide a discharge path for the huge charges to the earth and any possible damage to the building during thunderstorm is prevented.

M. Arshad
0300-9411

Photocopier

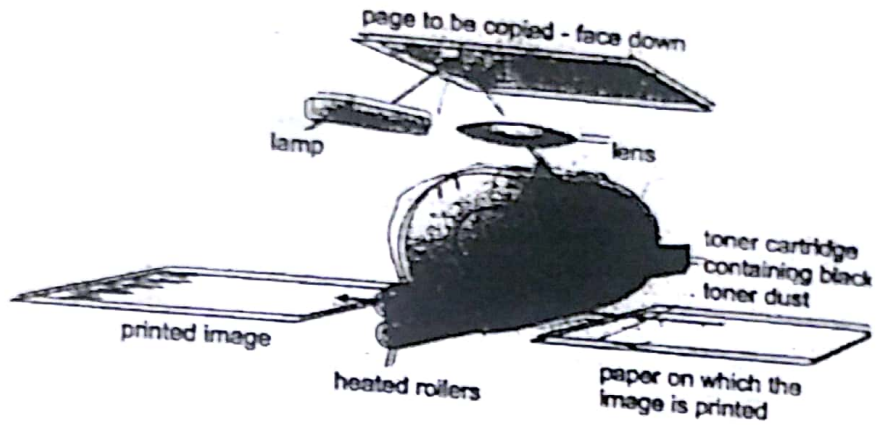

The heart of photocopier machine is a drum which is an Aluminium cylinder coated with the layer of Selenium. Aluminium is an excellent conductor. On the other hand, Selenium is an insulator in the dark and becomes a conductor when exposed to light. As a result, if a positive charge is sprinkled over the Selenium it will remain there as long as it remains in dark.

If a drum is exposed to an image of the document to be copied, the dark and light areas of the document produce corresponding areas on the drum. The dark areas retain their positive charge, but light areas become conducting, lose their positive charge and become neutral.

A special black powder called "Toner" is given a negative charge and spread over the drum, where it sticks to the positive charge areas. The donor from the drum is transferred on to a sheet of paper on which the document is to be copied. Heated pressure rollers then melt the toner into the paper to produce the permanent impression of the document.

Read & Write Publications
For Books Order: 0336-531411

UNIT 17

**Current
Electricity and
D.C. Circuit**

**O Level
Physics Teacher's Notes**

**M. A. Chaudhary
Cell: 0300-9412902**

Syllabus 2017 – 18**Current Electricity and D.C. Circuit**

- Basic Definitions
- Factors on which resistance depends
- Ohmic and Non-Ohmic Substances
- Electrical Symbols
- EMF and P.D
- EMF in series and in Parallel cells
- Combination of Resistors
- Apparatus arrangement
- Use of Ammeter in a circuit
- Use of Voltmeter in a circuit

Unit-17 CURRENT ELECTRICITY AND D.C. CIRCUIT

BASIC DEFINITIONS:

Current:

Rate of flow of charge.

$$I = \frac{Q}{t}$$

Where Q = charge passing, measured in coulomb(C).

t = time, measured in Seconds (s).

I = Current, measured in Amperes (A).

S.I Unit of current is Ampere (A)

Voltage:

Energy supplied per unit charge.

OR

Work done per unit charge.

$$V = \frac{E}{Q} \quad \text{or} \quad \frac{W}{Q}$$

Where E = energy supplied measured in Joule (J).

W = Work done, measured in Joule (J).

Q = Charge, measured in Coulomb (C).

V = Voltage, measured in Volt (V).

S.I Unit of voltage is Volt (V)

Resistance:

When the electrons are passing through a wire, they collide with the vibrating atoms of wire and their flow is disturbed. This effect is called as resistance. The resistance increases with the increase of temperature, because electrons collide more frequently with the vibrating atoms, at high temperature

FACTORS ON WHICH RESISTANCE DEPENDS:

1) Length of Wire:

Larger is the length of wire, higher is the resistance and vice versa.

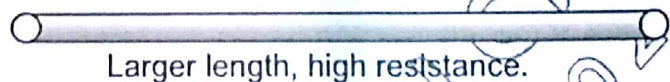
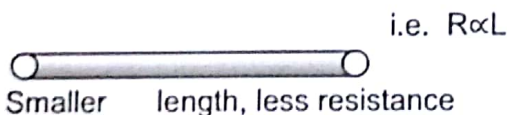

2) Cross-Sectional Area of wire:

Larger the cross-sectional area of wire, smaller is the resistance and vice-versa.

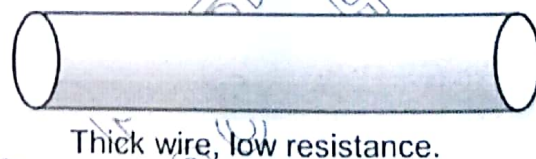
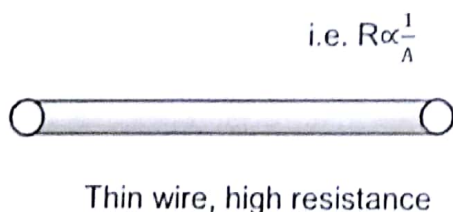

Ohm's Law

"The current passing through a wire is directly proportional to the potential difference across its ends, if temperature is kept constant."

i.e. $V \propto I$ if $T = \text{constant}$.

$$\text{Or } V = IR$$

Where R = resistance of wire.

The Unit of resistance is ohm (Ω).

The graph between I and V is straight line, passing through origin.

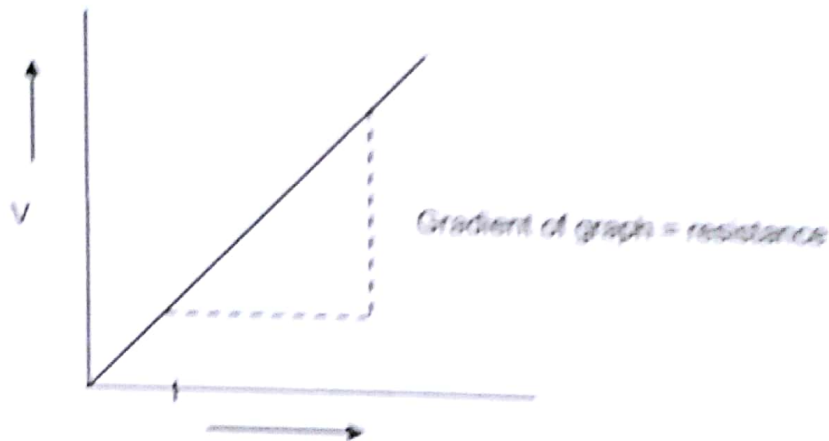
**OHMIC AND NON-OHMIC SUBSTANCES:**

- **Ohmic Substances** are those which obey Ohm's law i.e. I is directly proportional to V . The graph between I and V is straight line. e.g. pure metals are Ohmic substances.
- **Non-Ohmic Substances** are those which do not obey Ohm's law, i.e. I is not proportional to V . The graphs of some non-ohmic substances are given below.

Current - Voltage graph for filament lamp

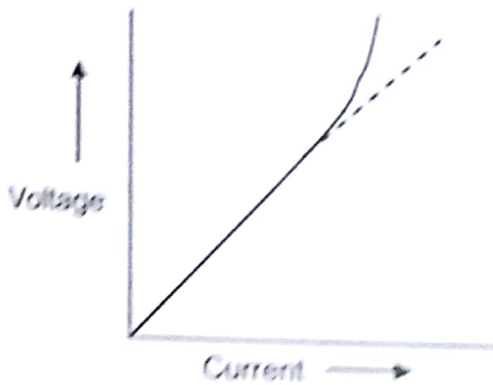

Current - Voltage graph for thermistor

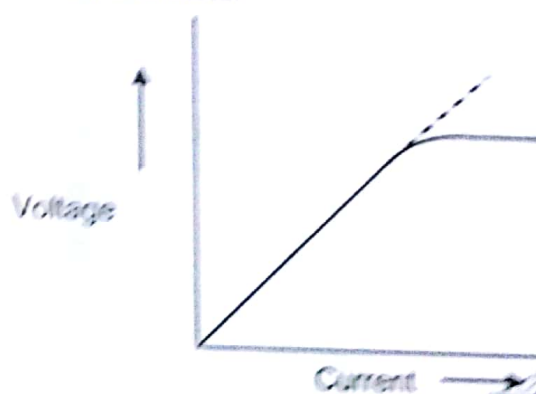

e.g. Filament lamp, Thermistor, Diode, LDR are Non-Ohmic substances.

ELECTRICAL SYMBOLS:

Common devices in electric circuits.

| Symbol | Device | Symbol | Device | Symbol | Device |
|--------|---------------|--------|---------------------------------|--------|-----------------|
| | Switch | | Lamp | | Galvanometer |
| | Cell | | Fixed resistor | | Ammeter |
| | Battery | | Variable resistor (or rheostat) | | Voltmeter |
| | Power supply | | Fuse | | 2 way switch |
| | Wires joined | | Coil of wire | | Earth connector |
| | Wires crossed | | transformer | | Capacitor |

EMF AND P.D:

- Emf-electromotive force:**

"The energy converted by a source in driving the unit charge around a complete circuit."

i.e. $emf = \frac{\text{Energy}}{\text{Charge}}$ or $\frac{\text{Work done}}{\text{Charge}}$ for the complete circuit.

Emf is measured in Volts.

- P.d Potential Difference:**

"The energy required in driving the unit charge through the component".

i.e. $P.d = \frac{\text{Energy}}{\text{Charge}}$ or $\frac{\text{Work done}}{\text{Charge}}$ for the component only.

P.d is also measured in Volts.

EMF IN SERIES AND IN PARALLEL CELLS:

Several cells are connected together to form a battery.

- The cells connected end to end, are in series combination, together they supply more energy than a single cell.



The total emf in series cells is given by

$$E = E_1 + E_2 + E_3$$

- The cells connected in parallel to each other are in parallel combination.

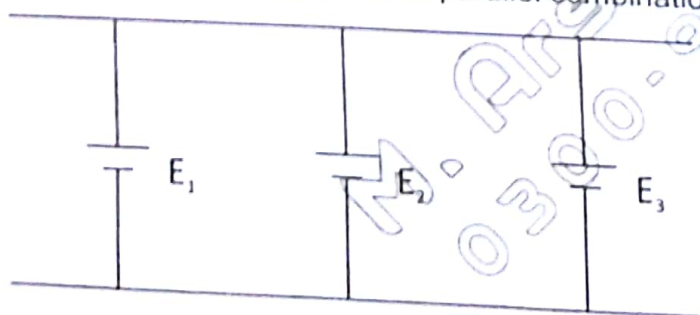

In parallel, the total emf supplied to the circuit by all cells is same, as provided by a single cell.
i.e. $E_1 = E_2 = E_3 = E$ (same)

- The advantages of making a battery from equal voltage cells in parallel are:-
- If one cell fails, the others continue to work.
 - They last longer.
 - They provide less resistance in circuit.
 - Less energy or heat is lost.

COMBINATION OF RESISTORS:

1) Series Combination:

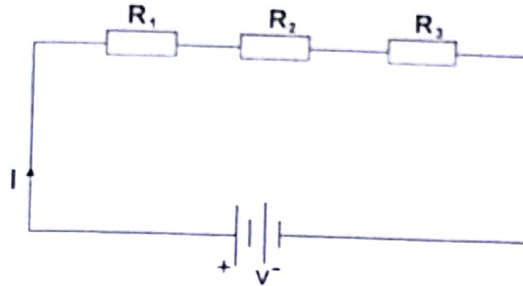

- The resistors are connected end to end, providing single path of current.
- The current in each resistor in series circuit is the same.
i.e. $I_1 = I_2 = I_3 = I$
- The sum of the Potential differences in a series circuit is equal to the Potential difference provided by cell battery.
i.e. $V_1 + V_2 + V_3 = V$
- The combined resistance in series circuit is given by
 $R = R_1 + R_2 + R_3$

2) Parallel Combination:

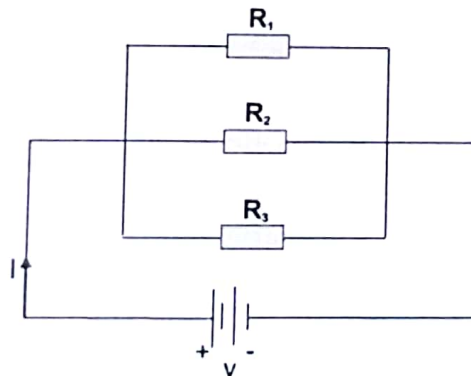

- The resistors are connected parallel to each other, providing different paths of current.
- The sum of currents in parallel circuit, is equal to current provided by cell or battery.
i.e. $I_1 + I_2 + I_3 = I$
- The potential difference across each resistor in Parallel circuit is the same.
i.e. $V_1 = V_2 = V_3 = V$
- The combined resistance in parallel combination is given by

$$\frac{1}{R} = \frac{1}{R_1} + \frac{1}{R_2} + \frac{1}{R_3}$$

Experiment: To measure the resistance of a given resistor.

Read & Write Publications
For Books Order: 0336-551411

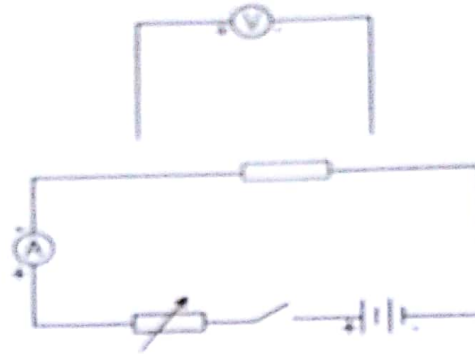
APPARATUS ARRANGEMENT:

- Set up the apparatus by connecting battery, switch, rheostat, ammeter and given resistor in series. The voltmeter is connected parallel to resistor.
- The + terminal of battery must be connected to + terminals of Ammeter and Voltmeter and vice versa.
- Close the switch and note the (A) and (V) readings.
- Use the formula $R = \frac{V}{I}$ to calculate resistance of given resistor.

USE OF AMMETER IN A CIRCUIT:**Key points:**

- Ammeter is used to measure current in a circuit.
- It is connected in series in a circuit.
- The + terminal of Ammeter is connected to + terminal of battery and vice versa.
- The Ammeters have different current ranges i.e. 0 to 1A, 0 to 5A, 0 to 10A etc. The milli-ammeter is also used to measure current in milli-amperes.

USE OF VOLTMETER IN A CIRCUIT:**Key points:**

- Voltmeter is used to measure emf of battery or P.d across a resistor or component.
- It is connected parallel to battery or parallel to given resistor.
- The + terminal of Voltmeter is connected to + terminal of battery and vice versa.
- The voltmeters have different ranges i.e. 0 to 1V, 0 to 5V, 0 to 10V etc.

M. Arshad Ch.
0300-9412902

UNIT 18

Practical Electricity

**O Level
Physics Teacher's Notes**

**M. A. Chaudhary
Cell: 0300-9412902**

Syllabus 2017 – 18

Practical Electricity

- Effects of Electricity
- Electrical energy and electrical power in a circuit
- Main features of house circuit are
- Hazards / Dangers of electricity

Unit-18 PRACTICAL ELECTRICITY

EFFECTS OF ELECTRICITY

1) Electric Heating:

When current is passed, heating effect is produced in the metal elements. The electrical energy is converted into elements, are used in electric heaters, electric kettles, electric irons, electric stoves etc.

2) Electric lighting:

The lighting effect of electric current is produced in two types of lamps:

a) Filament lamps:

When a current flows through the filament, the filament becomes white hot. The hot filament emits out radiations, which are made visible in bulbs, and thus lighting effect is produced.

b) Fluorescent lamps:

Fluorescent lamp has no filament but two electrodes. By passing current between these two electrodes, the mercury vapour in the glass tube emits out UV light and thus lighting effect is produced.

3) Electric motors:

The current produces magnetic effect. The magnetic effect of current is used to interact with other magnetic fields to produce movements in electric motors. The electric motors are used in appliances like fan, washing machine, electric drills, hair dryer etc.

ELECTRICAL ENERGY AND ELECTRICAL POWER IN A CIRCUIT:

Electrical Energy:

The electrical energy in a circuit is supplied by cell or battery. The electrical energy which is lost in the given resistor is called energy dissipation. The expressions for electrical energy are:

Electrical energy supplied by a cell $E = VIt$

Electrical energy dissipated in a resistor $E = I^2Rt$ or $E = \frac{V^2}{R}t$

Electrical Power:

The rate at which electrical energy is transmitted is called electrical power. The expressions for electrical powers are:

Electrical power supplied by a cell $P = VI$

Electrical power dissipated in a resistor $P = I^2R$ or $P = \frac{V^2}{R}$

Fuse:

- The symbol of fuse is 
- It is made up of thin metal wire of low melting point.
- If there is excess current, fuse wire melts due to heating effect, cutting off current to the appliance.
- Fuse is placed in LIVE wire so that appliance will not become live after the fuse has blown.
- The fuse rating is slightly higher than the current drawn by an appliance. Fuses are normally rated at 1A, 2A, 5A, 10A, 13A, 30A.

Live, neutral and earth wires:

1) Live wire:

- The wire through which current enters into an appliance.
- The live wire is at high voltage.
- Colour coding: Brown.

Neutral Wire:

- The wire through which current leaves the electrical appliances.
- The neutral wire is usually at zero volt.
- Colour coding: Blue.

2) Earth Wire:

- The wire which connects the metal casing of an appliance to earth. In case of short circuit the excessive current leaves the appliance for earth through this wire. The excessive current thus melts the fuse, cutting off further supply to the appliance.
- The earth wire is almost at zero volt.
- Colour coding: Green/Yellow.

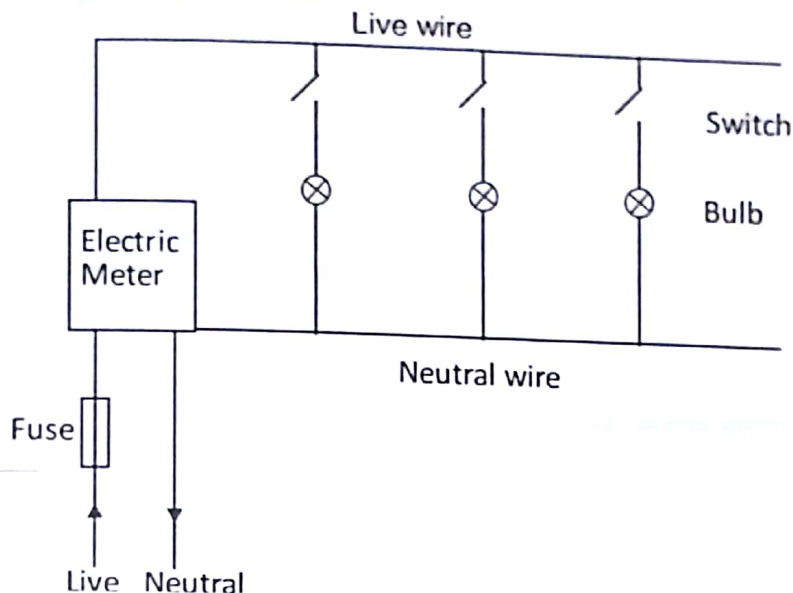
**MAIN FEATURES OF HOUSE CIRCUIT ARE:**

- The switches are placed in the Live wire for completing or breaking a circuit. If the switch is placed in the neutral wire the appliance will be 'Live' even if the switch is 'off'.
- The fuses are also placed in Live wire, to cut off excessive current before it damages the appliances.
- The house circuit is in parallel, due to following reasons:
 - a) Since parallel circuit has different paths for current. If one path to an appliance is damaged, others keep on working.
 - b) Each appliance is at the same voltage.
 - c) In parallel circuit, combined resistance is less, so more current can be drawn from the supply.
- The cost of electricity consumed in house is based on the number of units – KWh of electrical energy used.

$$\text{Cost} = \text{KWh} \times \text{rate}$$

Where KW = electrical power in Kilowatts.

h = time in hours.

Rate = value or amount of one unit – KWh.

HAZARDS / DANGERS OF ELECTRICITY:

The possible causes of dangers of electricity are:

- **Damaged insulation.**
- **Overheating of cables**
- **Damp conditions.**

Damaged insulation:

If plastic or rubber covering of Live wire is damaged then wire is exposed. The exposed wire can cause a severe electric shock to the user.

Overheating of cables:

A short circuit can result when the Live wire makes contact with the neutral wire due to damaged insulation. It produces a large current and thus large amount of heat generated can melt the insulation of wires.

Damp Condition:

The wetness provides conducting path to current. The hands of person should be dry when putting a plug into a socket to avoid an electric shock.

Safety Precautions:

The safety precautions must be observed to avoid hazards of electricity.

1) Double Insulation:

Use double-insulated wires wherever possible. If the outer insulation becomes damaged, the inner insulation can still prevent the live wire from being exposed.

2) Earthing metal cases:

Earth all electrical appliances. The earth wire will channel all excessive leakage current into the ground during a short circuit. The excessive current thus melts the fuse, cutting off further supply to the appliance.

3) Selection of fuse rating:

A fuse of a wrong value can allow more current to flow into an appliance, causing damage to the wires and appliance. So never replace a fuse with higher rating.

4) Good Connections:

All electrical connections should have good and tight contacts. Loose and poor contacts give high resistance at contact points, producing excess heat, which in turn will melt the insulation.

5) Wire a main plug safely:

To wire a main plug with the live (L), neutral (N) and earth (E) wires, the procedure is as follows:

M. Arshad Ch.
0300-9412902

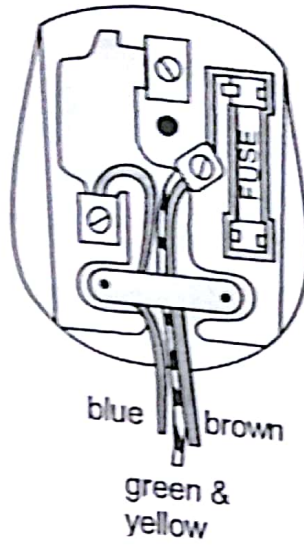

- By means of a cutter, remove the sufficient amount of insulation from each wire.
- Secure the three wires to the correct terminals according to their colour codes.
- Tighten the wires strongly with their respective terminals for producing good contacts.
- Place a fuse of correct rating with the terminal of Live wire.

Reed & Write Publications
For Books Order: 0336-531441

UNIT 19

Magnetism

**O Level
Physics Teacher's Notes**

**M. A. Chaudhary
Cell: 0300-9412902**

Syllabus 2017 – 18**Magnetism**

- Magnetic, Non-magnetic and Magnetized materials
- Properties of magnets
- To compare magnetic properties of iron and steel
- These observations can be explained in the table below
- Plotting of magnetic field lines with a compass

Unit-19 MAGNETISM

MAGNETIC, NON-MAGNETIC AND MAGNETIZED MATERIALS:

- The materials which are attracted towards a magnet are called as **Magnetic materials** e.g. Iron, Steel, Nickel, Cobalt etc.
- The materials which are not attracted towards a magnet are called as **Nonmagnetic material** e.g. Brass, Copper, Wood, Glass etc.
- The materials which are able to keep magnetism for a long time are called as **Magnetized materials** e.g. permanent magnets.

PROPERTIES OF MAGNETS:

- They always attract the magnetic materials like iron, steel etc.
- A magnet suspended freely always align itself in the North-South direction. The end of magnet seeking the north direction is called N-pole and the other end is the S-pole.
- Like poles repel and unlike poles attract each other.
- The region around a magnet, within which it can attract magnetic materials, is called its magnetic field.

Induced Magnetism:

"It is the process of inducing magnetism in a magnetic material, without any contact with the magnet."

For example, when a magnet is placed above the iron nails, then a chain of nails is attracted towards magnet. It means the magnetism of magnet is induced in the iron nails.

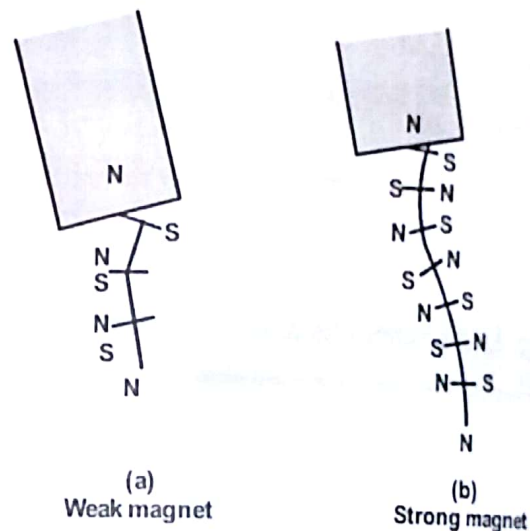

(a) Weak magnet

(b) Strong magnet

Electrical method of Magnetization:

A solenoid consists of copper coil, which is wound around a soft iron or steel core. When Direct Current (D.C) is passed through the Solenoid then soft iron or steel core is strongly magnetized. The D.C is passed for seconds i.e. just switch on and then switch off the current.

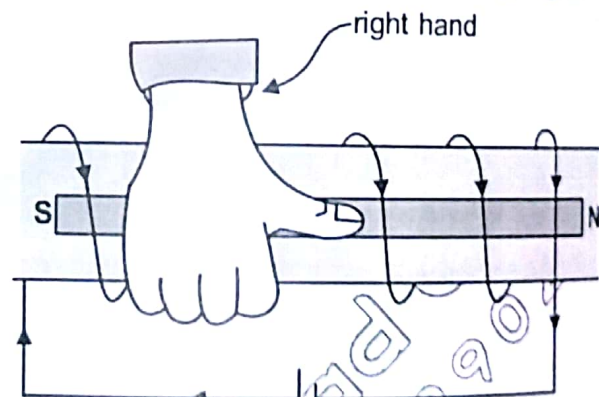

Detection of Poles:

The nature of poles produced on an electromagnet are determined by Right-Hand Grip Rule: "Grip the solenoid with the right hand such that the fingers are in the direction of the current and thumb points towards N-pole."

Strength of magnet:

The magnet produced by passing D.C is called **electromagnetic**. The strength of magnetism in an electromagnetic can be increased:

- By passing more current through the Solenoid.
- By increasing number of turns on the coil.

Electrical method of Diamagnetism:

Place a magnet inside a solenoid and pass alternating current (A.C). Slowly pull out the magnet from solenoid before switching off. The magnet would be demagnetized.

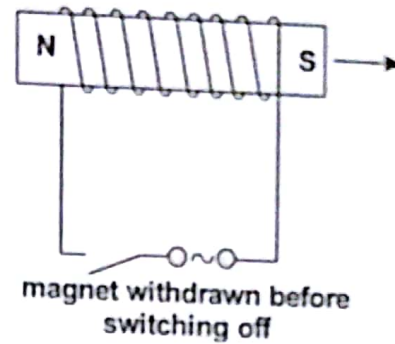
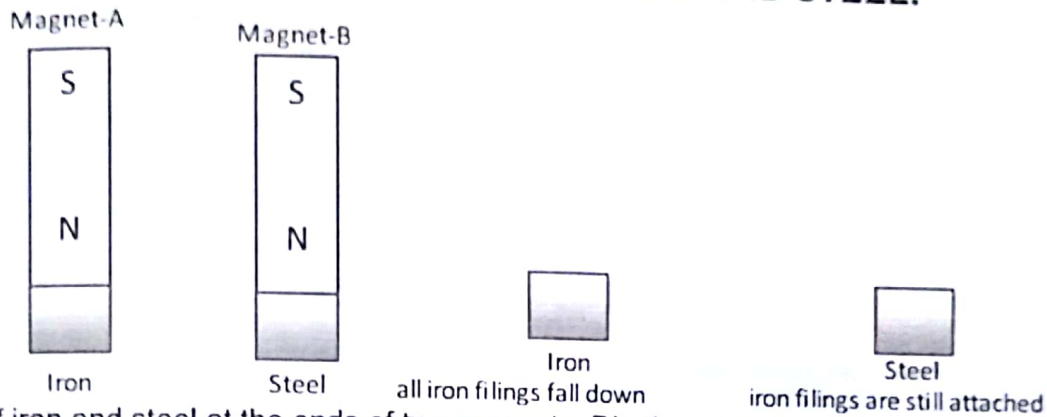
**TO COMPARE MAGNETIC PROPERTIES OF IRON AND STEEL:**

Fix pieces of iron and steel at the ends of two magnets. Dip them into iron filings. Magnet-A picks up large number of iron filings as compared to magnet-B. Now separate the pieces of iron and steel from their respective magnets. All iron-filing fall down from piece of iron and hardly any iron-filing falls from piece of steel.

THESE OBSERVATIONS CAN BE EXPLAINED IN THE TABLE BELOW:

| Magnetic Properties of iron | Magnetic properties of steel |
|---|---|
| 1) Iron can easily be magnetized and demagnetized. | 1) Steel is hardly magnetized and can retain magnetism for longer time. |
| 2) Iron can be magnetized by a weak magnetic field. | 2) Steel requires a strong magnetic field to magnetise |
| 3) Iron is used for making temporary magnets. | 3) Steel is used for making permanent magnets. |
| 4) Iron magnets are very stronger | 4) Steel magnets have less strength as compared to iron magnets. |

Uses of Permanent Magnets:

The hard magnetic materials such as steel are used in the making of permanent magnets.

The permanent magnets are used:

- In making bar magnets.
- In making needles of plotting compass.
- In making magnetic door catchers.
- In devices like loudspeakers, motors, generators etc

Uses of Temporary Electromagnets:

The soft magnetic materials such as iron are used in the temporary electromagnets. The temporary electromagnets are used.

- In magnetic shielding.
- In cranes to lift heavy pieces of iron/steel.
- In devices like electric bell, transformer, magnetic relay, read switch etc.

Use of magnetic materials in audio/video tapes:

Audio and Video Cassettes consist of a tape of magnetic material on which sound saved in a particular form of magnetic field. For this purpose sound waves are changed into electric pulses which are made by amplifier. Magnetic tape of the cassette is moved through the head of audio cassette recorder which is in fact an electromagnet. Change of current in the wire wrapped on the electromagnet causes a change in linked magnetic field. Thus magnetic tape is magnetized in particular form according to rise and fall of current. In this way sound is stored in a specific magnetic pattern in this tape.

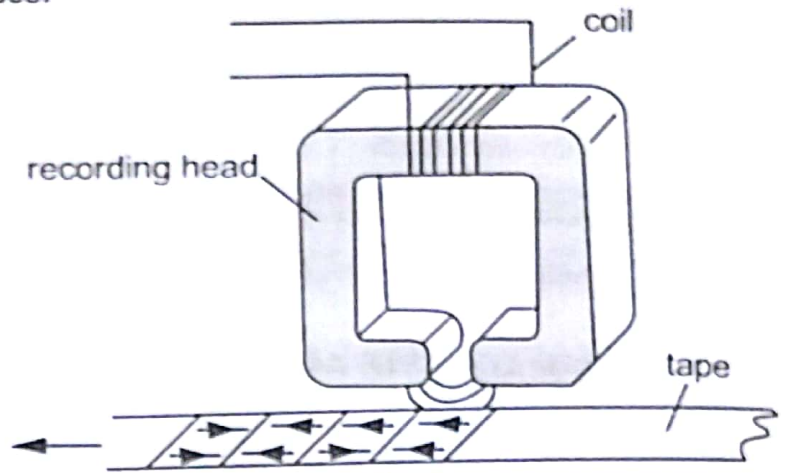

Fig.5.1

Magnetic Field:

"The space around a magnet within which it can exert force on magnetic objects".

The direction of magnetic field is represented by magnetic field lines. The magnetic field lines have following properties:

- Magnetic field lines start from N-pole and end on S-pole.
- Lines do not intersect each other.
- If lines at a point are closer, the magnetic field is stronger there and vice versa.
- The magnetic field lines between two like poles produce neutral point. At this point resultant field is zero.

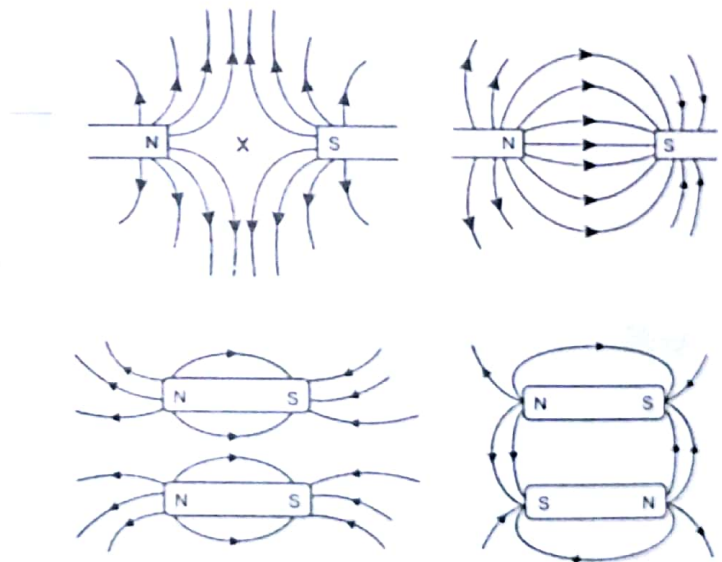

PLOTTING OF MAGNETIC FIELD LINES WITH A COMPASS:

Keep the plotting compass near the N-pole of magnet. Mark a dot where compass needle points. Shift the S-position of needle on dot and mark a new dot where the compass now points. Similarly mark a series of dots from North to South pole of magnet. Join these dots to plot magnetic field lines around a bar magnet.

M. Arshad
 0300-9412902

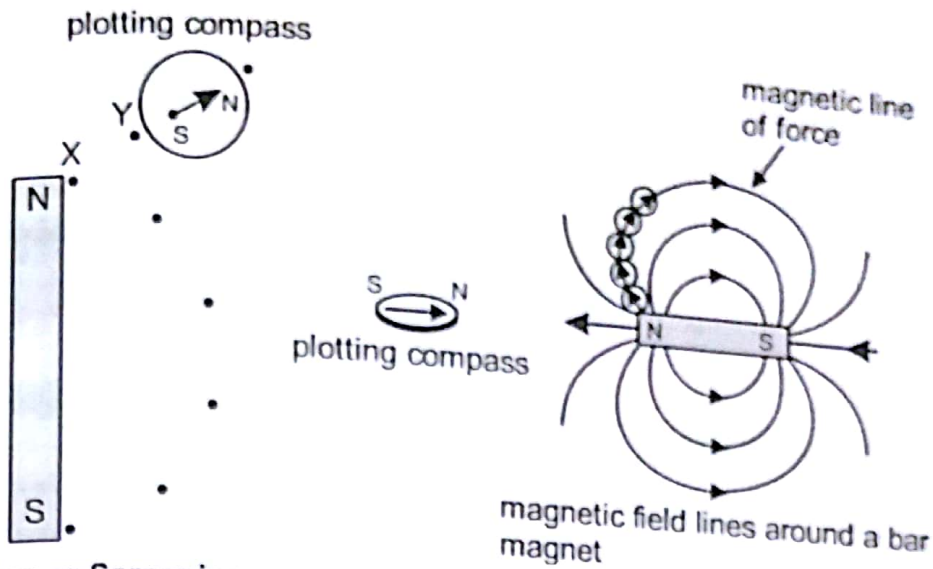

Magnetic Shielding or Screening:

"The process in which certain equipments or instruments are protected from influence of magnetism."

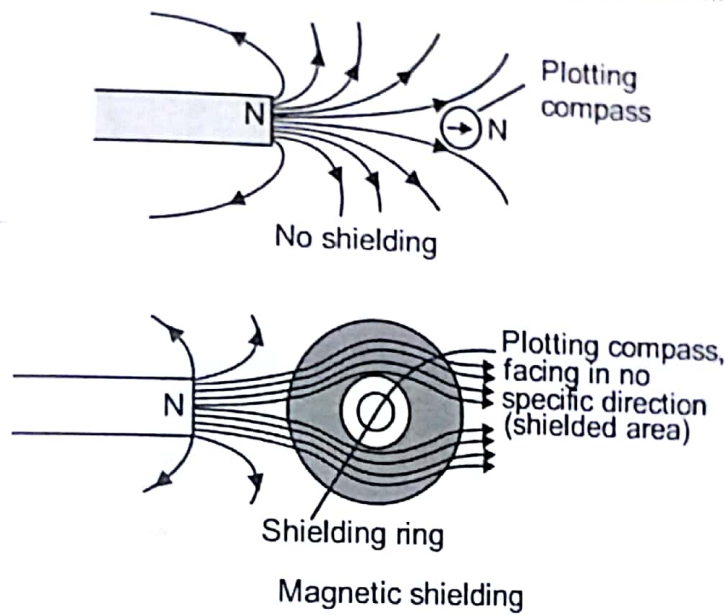

Explanation:

Some equipments or instruments need a magnetism-free surrounding for proper operation. For this purpose, the given equipment is kept in soft iron ring. Since soft iron is easily magnetized, it can draw some neighboring magnetic field lines into itself. Thus the area within the soft iron has no magnetic field line. Hence the area within the ring is said to be "shielded" from magnetic influence.

Read & Write Publications
For Books Order: 0336-5314141

UNIT 20

**Electromagn-
etism**

**O Level
Physics Teacher's Notes**

**M. A. Chaudhary
Cell: 0300-9412902**

Syllabus 2017 – 18**Electromagnetism**

- Magnetic field pattern due to current in straight wire
- Right – Hand Grip Rule
- Factors on which magnetic field depends
- Magnetic field pattern due to current in Solenoid
- The strength of Magnetic Field due to current in solenoid can be increased
- Application of Magnetic Effect of current
- Electric Bell

Unit-20 ELECTROMAGNETISM

MAGNETIC FIELD PATTERN DUE TO CURRENT IN STRAIGHT WIRE:

When current is passed through a wire, then magnetic field is produced around the current carrying wire. The pattern of the magnetic field is in the form of concentric circles.

The presence of magnetic field around the current carrying wire can be detected by the deflection of needle of plotting compass.

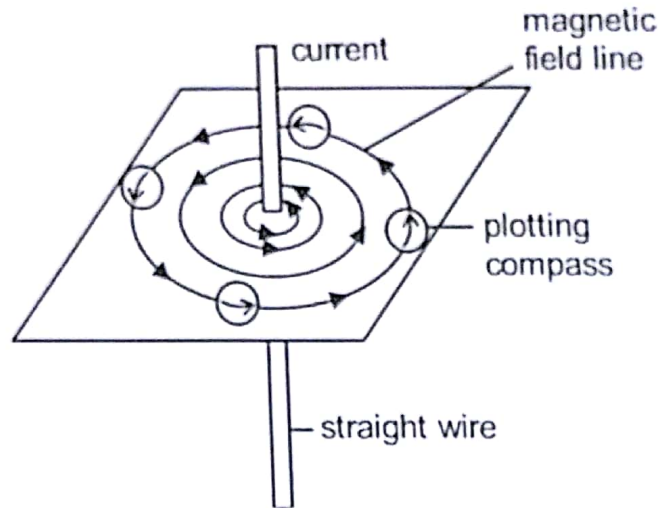

Right – Hand Grip Rule:

The direction of magnetic field around the current carrying wire is determined by right hand grip rule. "Grip the wire with right hand such that thumb points the direction of current and curl of fingers in the direction of magnetic field."

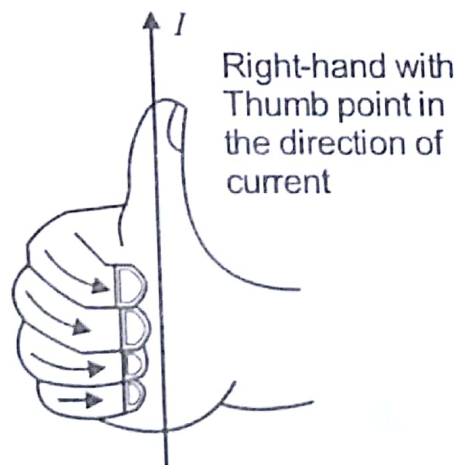

Factors on which magnetic field depends:

The factors influencing the magnetic field around a straight wire are:

1. Increasing the current, increases the strength of magnetic field.
2. Reversing the current, reverses the direction of magnetic field.
3. Increasing the distance from wire decreases the strength of magnetic field. That's why concentric circles are closer near the wire and wider away the wire.

Magnetic field pattern due to current in Solenoid:

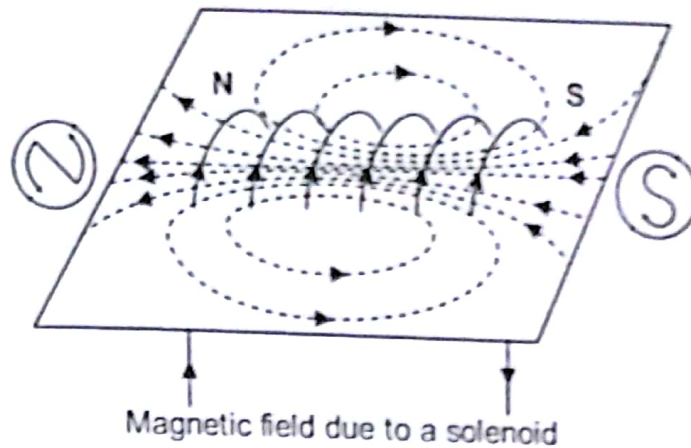

Magnetic field due to a solenoid

The magnetic field pattern of a solenoid is similar to that of a bar magnet. The magnetic field emerges from N – end of the solenoid and goes into S- end. The magnetic field is stronger inside the Solenoid because concentration of magnetic field lines is larger there.

The strength of Magnetic Field due to current in solenoid can be increased:

- By increasing the current.
- By increasing number of turns on solenoid.
- By using soft iron core inside the solenoid.

Application of Magnetic Effect of current:

The magnetic effect of current is used in the following electrical devices:

- Electrical bell
- Magnetic relay
- Reed relay
- Circuit breaker

The diagram and working of each device is described below:

Electric Bell:

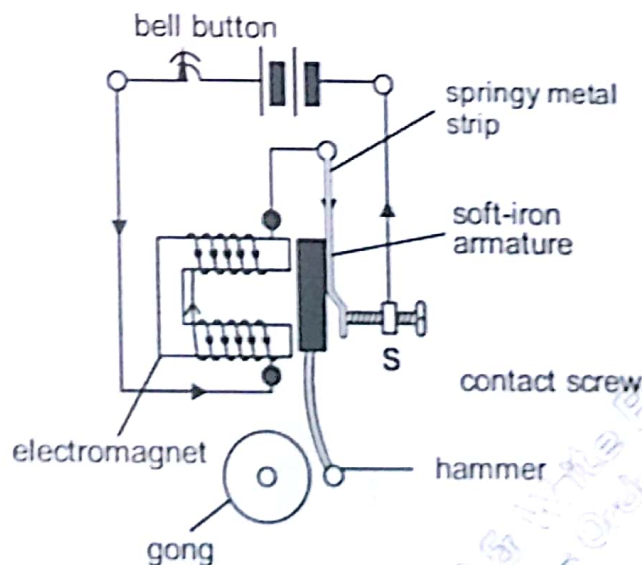

Working:

When current is passed, the soft iron core or electromagnet is strongly magnetized. It attracts the armature and hammer strikes the gong, producing sound. The circuit breaks from the contact screw, current is cut off and electromagnet loses its magnetism immediately. So armature gets back to its original position completing the circuit again and same process is repeated continuously.

Magnetic Relay:

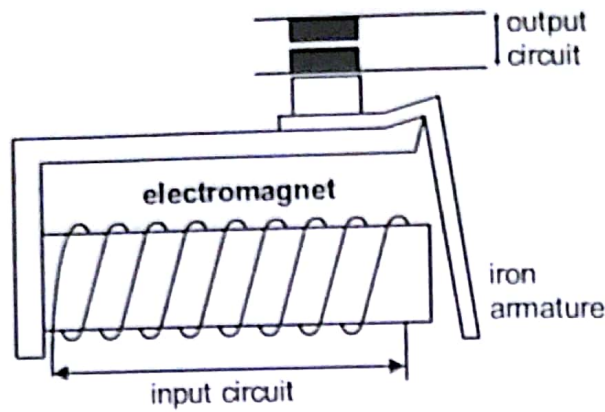

A simple magnetic relay

Working:

The magnetic relay consists of two circuits i.e. input circuit and output circuit. The input circuit, which works at low current, can be used to control output circuit, which works at a high current.

When small current is passed, soft iron core or electromagnet is strongly magnetized. It attracts the free end of armature and the other end is pivoted upwards, joining the contacts of external circuit.

Reed Relay:

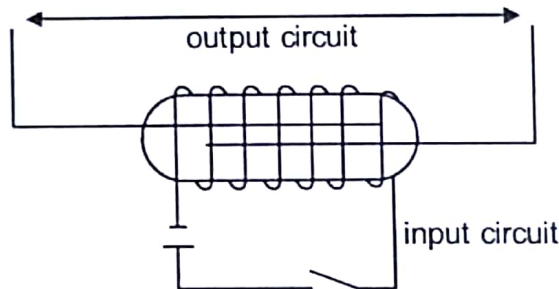

A reed relay

Working:

The reed relay consists of a pair of soft iron strips having a small gap between them. The pair of soft iron strips called as reeds, is kept inside the solenoid.

When current is passed through the solenoid by input circuit, the reeds are magnetized and attract each other, closing the contacts of output circuit.

When current in the solenoid is switched off, the reeds lose their magnetism, separating the contacts of output circuit again.

Circuit Breaker:

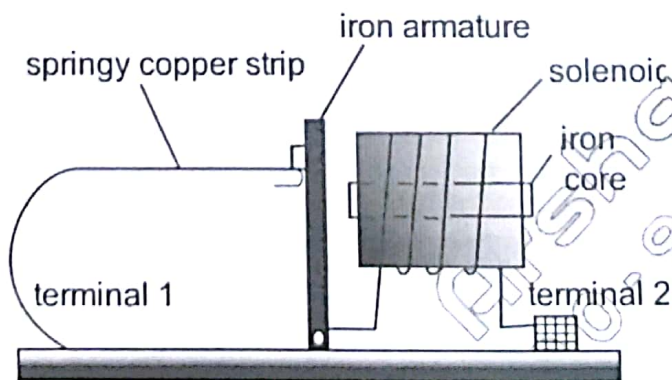

A circuit breaker

Working:

A circuit breaker is used to switch off the current if it exceeds beyond certain limit in a circuit. The current, flows from Terminal 1 → Springy copper strip → Iron armature → Solenoid → Terminal 2. When current becomes excessive, the iron core inside Solenoid is strongly magnetized and attracts the iron armature. As the armature moves towards solenoid circuit breaks from contact, cutting off the large current.

Read & Write Publications
For Books Order: 0336-5314141

UNIT 21

Magnetic Force

**O Level
Physics Teacher's Notes**

**M. A. Chaudhary
Cell: 0300-9412902**

Syllabus 2017 – 18

Magnetic Force

- Experiment to demonstrate the force on a current carrying conductor
- Application of magnetic Force
- D.C. Motor
- Moving coil-loudspeaker

Unit-21 MAGNETIC FORCE

EXPERIMENT TO DEMONSTRATE THE FORCE ON A CURRENT CARRYING CONDUCTOR:

When a current carrying wire is placed in a magnetic field then a magnetic force is produced on the wire. Suppose a stiff copper wire is placed at right angles to the field, provided by U-shaped magnet. When switch is closed, a current flows through the wire. The wire moves upwards, indicating that an upward force acts on wire.

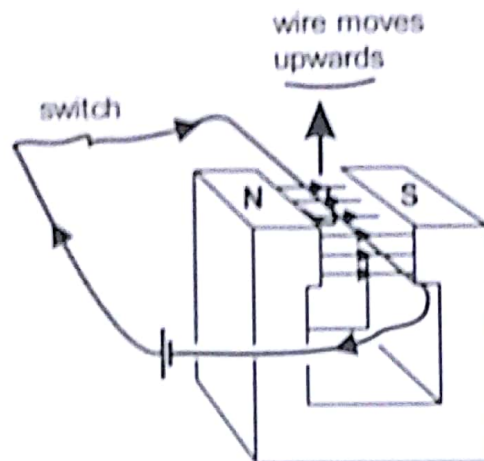

Observations:

The magnitude of magnetic force on the current carrying conductor is increased:

- By increasing strength of a magnetic field.
- By increasing amount of current passing.

The direction of magnetic force on the current carrying conductor is reversed:

- By reversing the direction of current.
- By reversing the direction of magnetic field.

Fleming's left-hand rule:

The direction of magnetic force is determined by Fleming's left-hand rule.

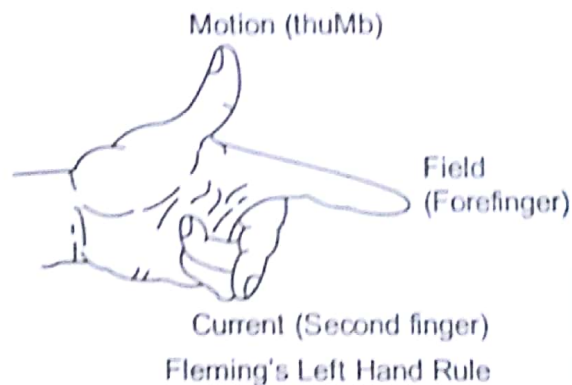

Stretch the second finger, forefinger and thumb of left hand mutually perpendicular to each other such that:

- Second finger indicates direction of current (I).
- Forefinger indicates direction of magnetic field (M).
- Thumb indicates direction of force (F).

In applying Fleming's left hand rule, the following must be observed:

- The direction of magnetic field is always from N-pole to S-pole of a magnet.
- The rule applies only, where the current and field directions are perpendicular to each other.

- > The direction of current is taken OPPOSITE to flow of electrons i.e. conventional current direction is considered.

Application of Fleming's left-hand rule:

1) Force on Current carrying coil in a magnetic field:

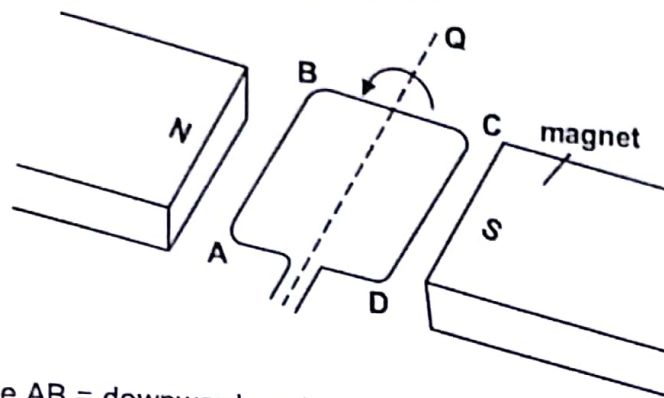

Force acting on side AB = downwards or into page \otimes

Force acting on side CD = upwards or out of page \odot

No forces act on sides BC or AD, since current and field directions are not perpendicular in this case.

2) Force on current carrying conductor in a magnetic field:

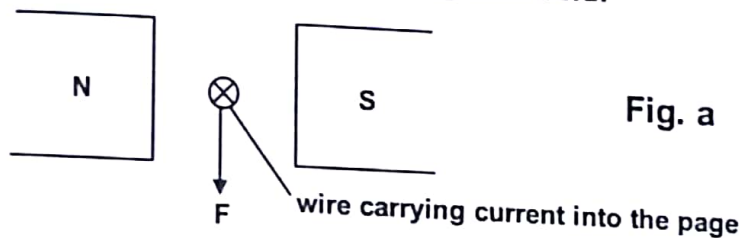

Fig. a

wire carrying current into the page

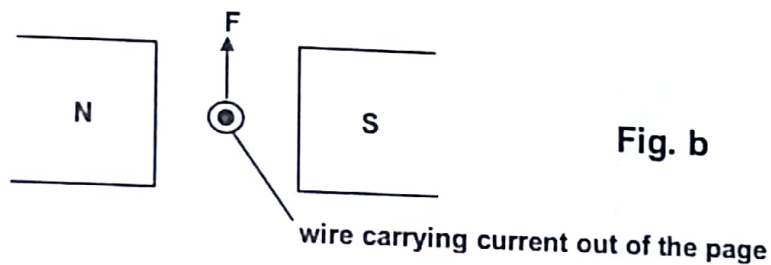

Fig. b

wire carrying current out of the page

Fig (a): The direction of the force on the wire carrying current into the page is downwards.

Fig (b): The direction of the force on the wire carrying current out of the page is upwards.

3) Force on moving charges in a magnetic field:

- If the Fleming's left-hand rule is applied to a beam of electrons, the direction of CURRENT is OPPOSITE to the flow of electrons.
- If Fleming's left-hand rule is applied to a beam of protons, the direction of CURRENT is SAME as that of flow of protons.

Read & Write Publications
For Books Order: 0336737111

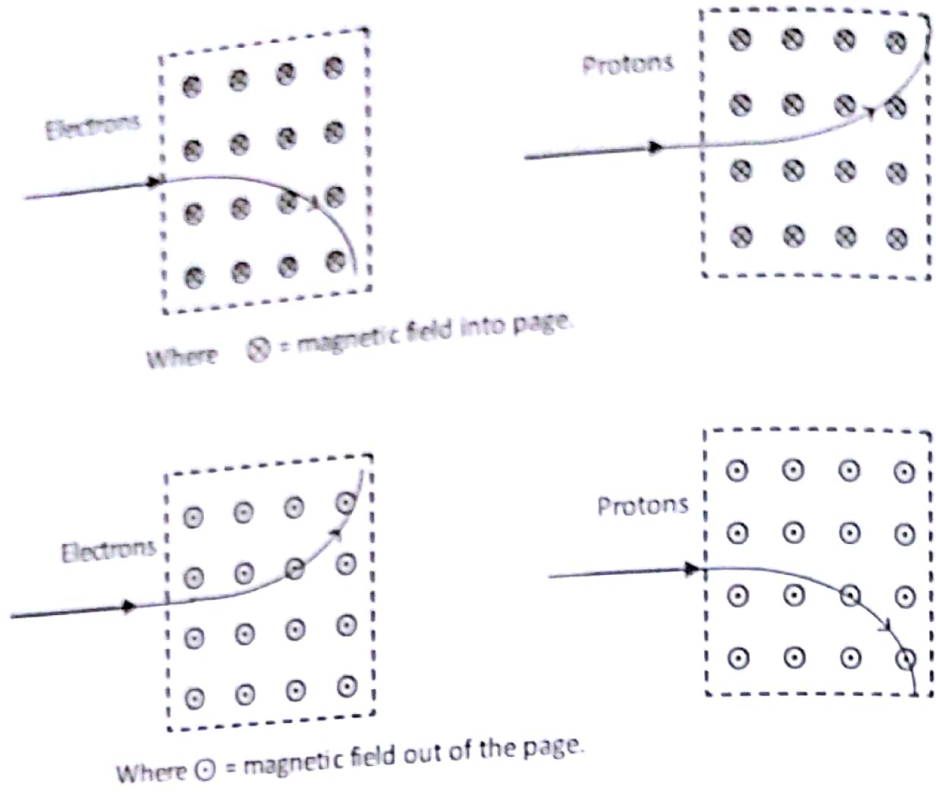

APPLICATION OF MAGNETIC FORCE

- D. C Motor
- Moving Coil – loudspeaker

D.C. MOTOR:

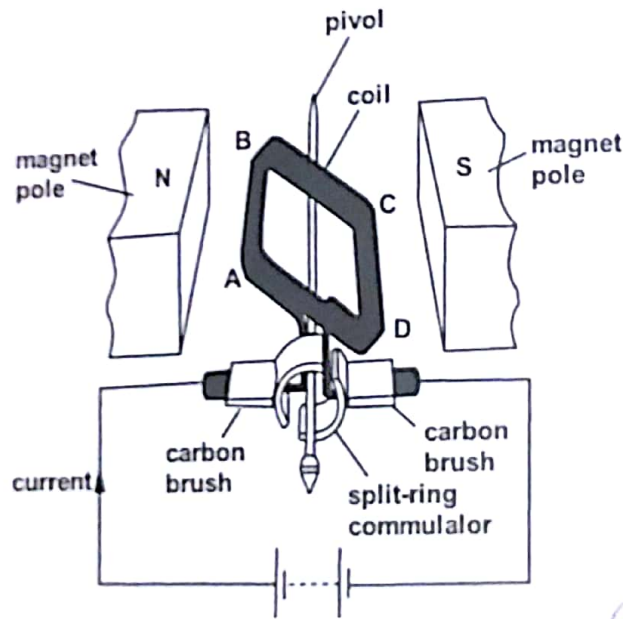

Working:

When current is passed, the rectangular coil ABCD rotates between poles of magnet, due to magnetic force. According to Fleming's left-hand rule, on side AB force acts downwards and on side CD force acts upwards. These forces being equal in magnitude, but opposite in direction rotate the rectangular coil in an anticlockwise direction.

Function of Split-ring Commutator:

It reverses the direction of current in the coil. With the result the direction of forces is also reversed and the coil continues to rotate in the same direction.

Functions of carbon brushes:

They avoid the friction between the split-ring commutator and the circuit wires. Moreover the circuit wires do not tangle over with the split ring commutator in the presence of carbon brushes.

Factors increasing speed of Coil:

The turning effect of rectangular coil can be increased:

- By increasing number of turns on coil.
- By increasing a current.
- By using stronger magnet.
- By using soft-iron core inside the coil.

MOVING COIL-LOUDSPEAKER

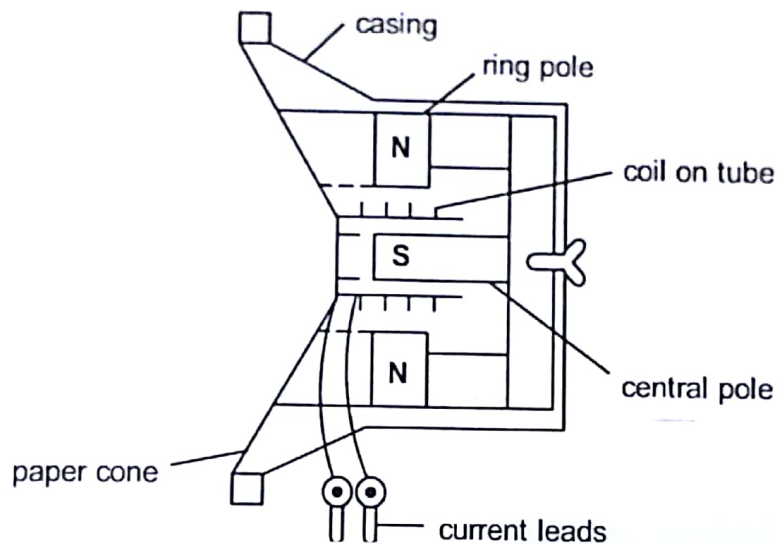

Working:

When an alternating current is passed to the coils, through current leads, then a magnetic force is produced on the coils. As the current is alternating, so magnetic force on the coils varies rapidly in magnitude as well as in direction. This causes the coils to oscillate with very high frequency.

Since the paper cone is attached to the coils so oscillations are set up in the cone as well as in the layer of air next to the cone. In this way alternate series of compressions and rarefactions in the air are set up producing sound waves in the air.

Force between two parallel current carrying wires:

Two current-carrying wires placed parallel to each other experience a magnetic force, due to the interaction of their magnetic fields:



(a) Unlike currents repel

(b) Like currents attract

- Parallel wires with currents in the same direction, attract each other.
 - Parallel wires with current in opposite direction, repel each other.
- "Like currents attract, unlike currents repel."

The interaction of magnetic fields of like and unlike currents is described in the diagrams below:

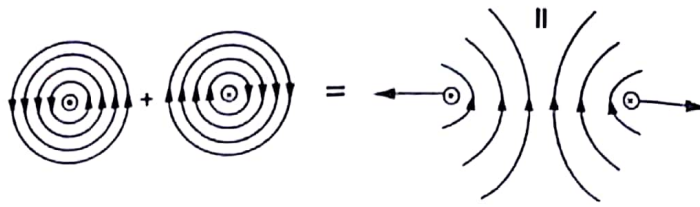

(a) Combining magnetic fields due to currents in opposite directions

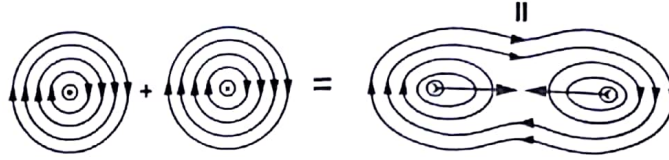

(b) Combining magnetic fields due to currents in the same direction

M. Arshad Ch.
0300-9412902

UNIT 22

**Electromagne-
tic Induction**

**O Level
Physics Teacher's Notes**

**M. A. Chaudhary
Cell: 0300-9412902**

Syllabus 2017 – 18**Electromagnetic Induction**

- The Phenomenon of Electromagnetic Induction
- Laws of Electromagnetic Induction
- Direction of induced current in the conductor
- A.C Generator
- Transformer
- Energy losses in transformer

Unit-22 ELECTROMAGNETIC INDUCTION

THE PHENOMENON OF ELECTROMAGNETIC INDUCTION:

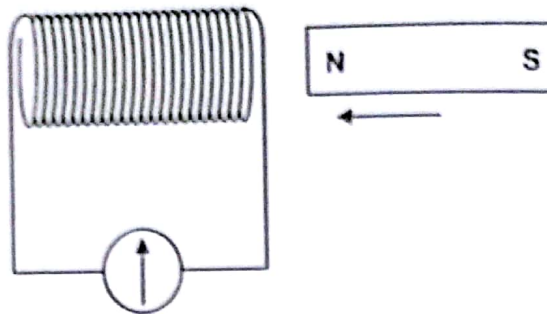

When a magnet is moved towards coil, galvanometer deflects, showing presence of current in the coil. If magnet is moved away from the coil, galvanometer deflects in opposite direction showing current in the coil in reverse direction. However if magnet is stationary near the coil, galvanometer does not deflect i.e. no current is observed.

These observations can be explained with following basic terms.

- 1) **Magnetic Flux:**
The magnetic field lines cutting the coil is called magnetic flux.
- 2) **Induced emf:**
The driving force of electrons in the coil produced due to cut of magnetic flux.
- 3) **Induced Current:**
The rate of flow of electrons in the coil, hence which is produced due to cut of magnetic flux.
- 4) **Electromagnetic Induction:**
It is the process in which an emf and hence a current is induced in the coil, due to cut of magnetic flux.

LAWS OF ELECTROMAGNETIC INDUCTION:

1. **Farady's Law:**
"The induced e.m.f (current) is directly proportional to the rate of cut of magnetic flux."
The induced emf in the coil can be increased:
 - By using a stronger magnet
 - By increasing number of turns in the coil
 - By using soft iron core inside the coil.
 - By moving the magnet faster.
2. **Lenz's Law:**
"The induced current is produced in such a direction that it opposes the cause producing it."

M. Arshad Ch.
0300-9412902

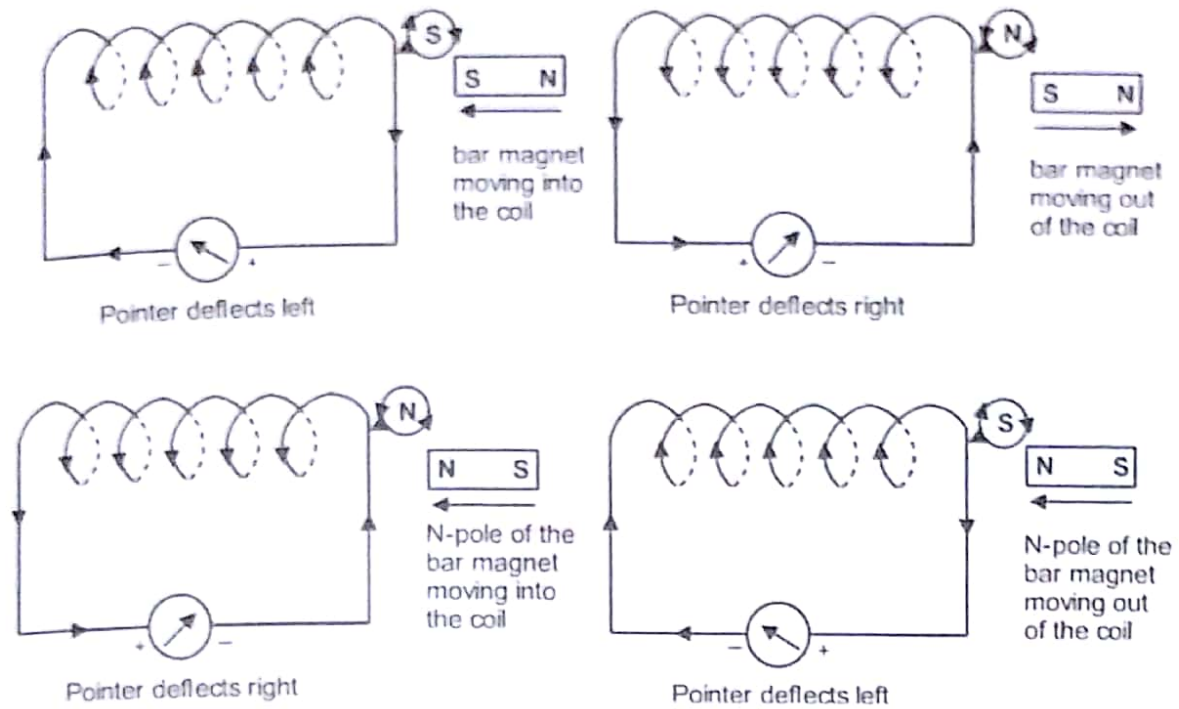

The above diagrams show that the induced current in the coil is produced in such a direction that it opposes the motion of the magnet.

DIRECTION OF INDUCED CURRENT IN THE CONDUCTOR:

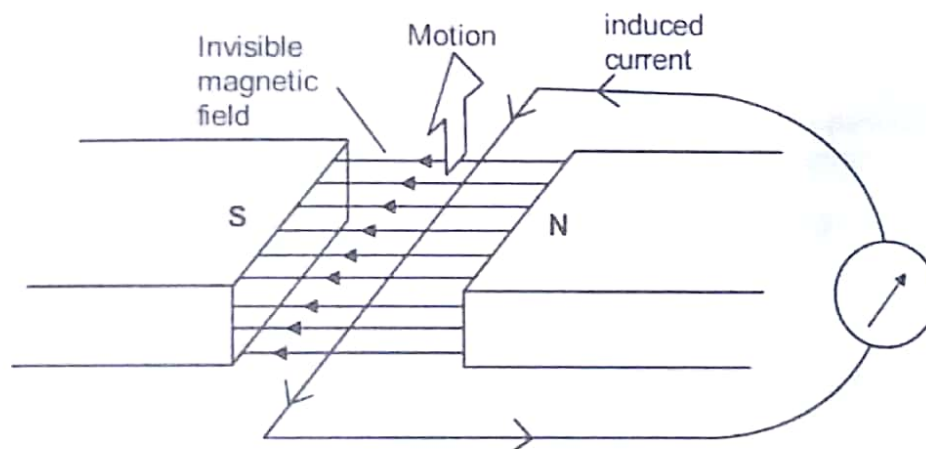
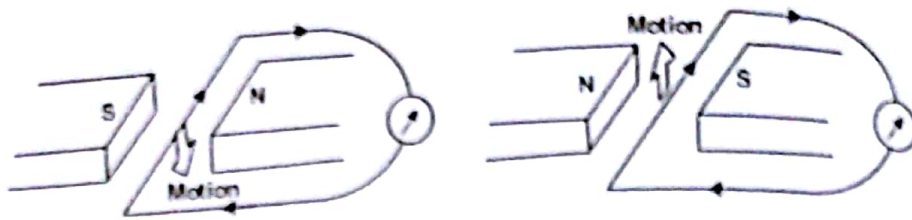

Fig. shows a wire cutting the magnetic field between poles of a magnet. The current is induced in the wire due to cut of magnetic flux. The direction of the induced current in the wire can be determined by using Fleming's Right-Hand Rule:

"If the Thumb points in the direction of motion of wire and Forefinger points in the direction of magnetic field, then Second finger will indicate direction of induced current in the wire."



Fleming's Right Hand Rule can be applied to the following examples



A.C GENERATOR:

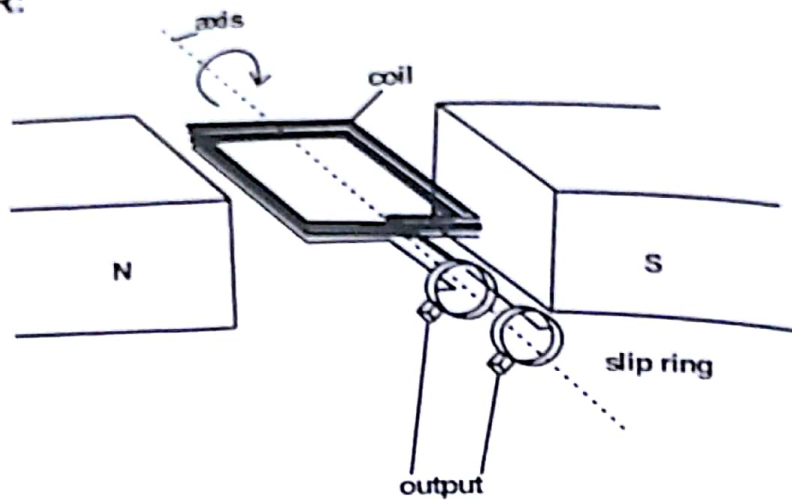

Working:

When the coil is rotated between poles of magnet then due to cut of magnetic flux an emf is induced in the coil.

- 1) When the coil is in vertical position, cut of magnetic flux is zero and no emf is induced in the coil.
- 2) When coil is in horizontal position, cut of magnetic flux is maximum so maximum e.m.f is induced in the coil.

Therefore e.m.f induced in the coil varies in magnitude as well as in direction. Such an e.m.f is called alternating e.m.f or alternating current (A.C).

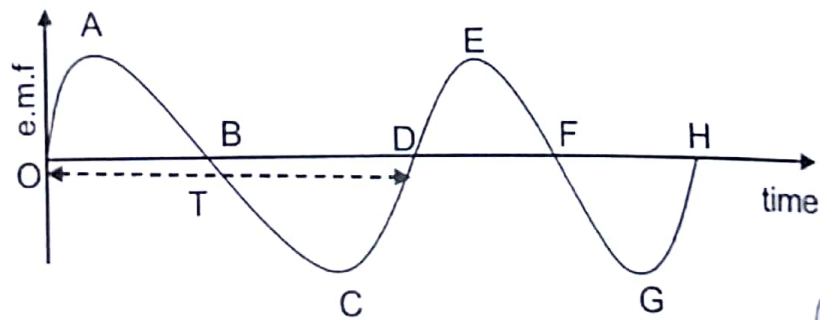

- At points O, B, D, F and H coil is in vertical position, because e.m.f induced is zero.
- At points A, C, E and G coil is in horizontal position, because e.m.f induced is maximum.

The induced e.m.f and therefore the induced current can be increased:

- By rotating the coil at high speed.
- By using a coil with more turns.
- By using a stronger magnet.
- By using soft iron core in the coil.

Function of Slip rings:

The current induced in the coil is passed to the output circuit through the slip rings. So slip rings act as a bridge between the current induced in the coil and the output circuit.

Graphical Changes on Induced Current produced by a.c. generator:

1. If number of turns in the coil one doubled, the induced e.m.f is also doubled.

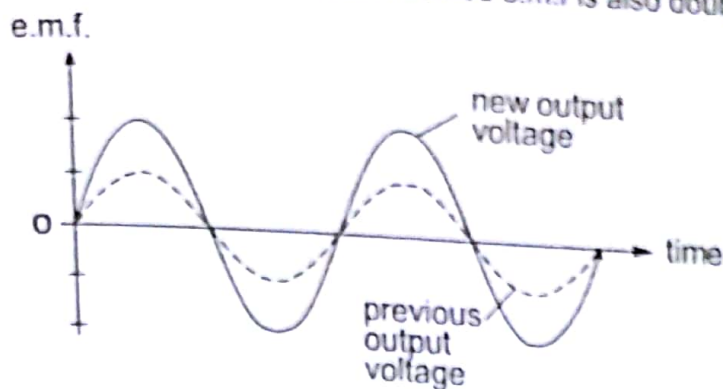

Doubling the turns doubles the maximum output voltage

2. If magnet of double strength is used, the induced e.m.f also becomes double.

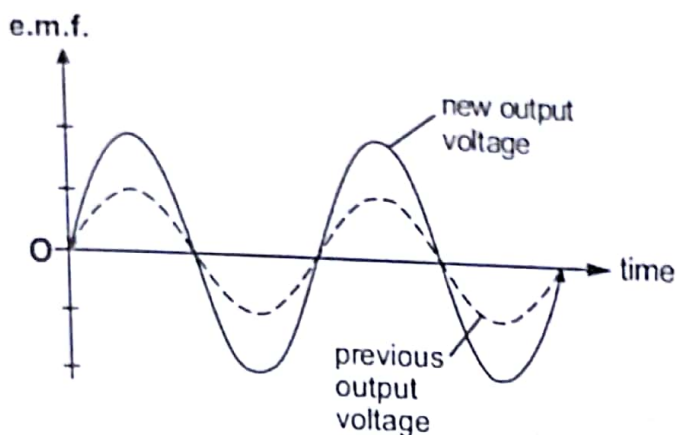

Doubling the turns doubles the maximum output voltage

3. If speed of coil is doubled, the induced e.m.f as well as frequency of coil becomes double.

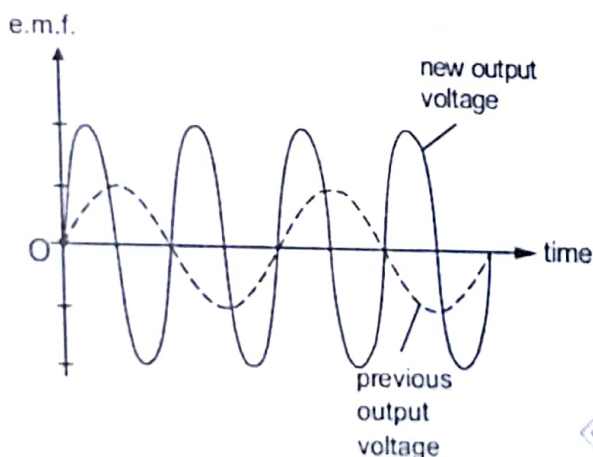

Doubling the speed doubles the maximum output voltage

4. If speed of coil is reduced to half of its original value, then e.m.f. induced as well as frequency of coil becomes half.

The e.m.f vs time graph will be the reverse graph of the above diagram.

Re-White Publications
For Bulk Order: 0336-5314141

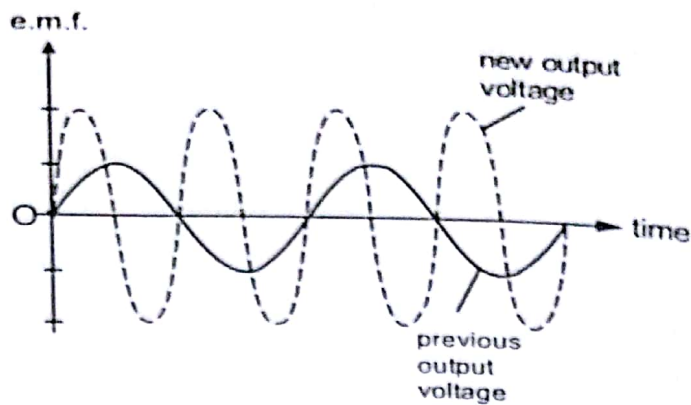

Reducing the speed reduces the output voltage as well as frequency.

TRANSFORMER:

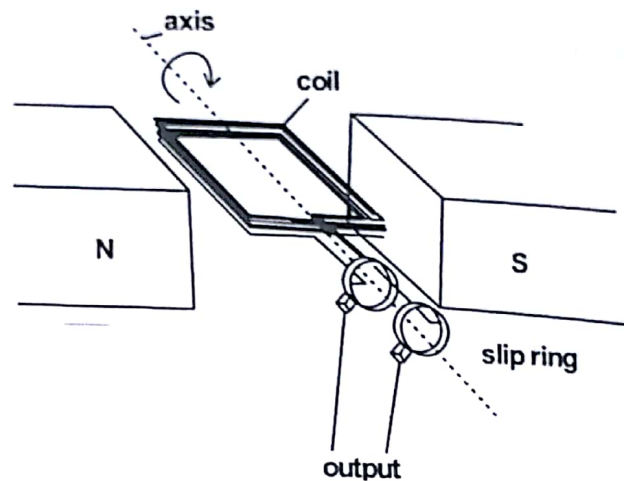

Use: it is used to step up or step down the voltage.

Construction:

A transformer consists of:

Primary coil – connected to a.c supply.

Laminated soft iron core—consists of different iron sheets separated by insulating material.

Secondary coil – connected to output circuit.

Working:

When a.c is passed in primary coil, then a changing magnetic field is produced. The magnetic field lines travel through the soft iron core and cut the secondary coil. Due to cut of magnetic flux, an e.m.f is induced in the secondary coil. The transformer works under the equation:

$$\frac{N_s}{N_p} = \frac{V_s}{V_p}$$

Where N_s = Number of turns on secondary coil.

N_p = Number of turns on primary coil.

V_s = voltage across secondary coil.

V_p = voltage across primary coil.

(a) If $N_s > N_p$, then $V_s > V_p$ i.e. Step Up Transformer.

(b) If $N_s < N_p$, then $V_s < V_p$ i.e. Step Down Transformer.

For an ideal transformer, which is 100% efficient:

Power Input = Power Output.

$$V_p I_p = V_s I_s$$

ENERGY LOSSES IN TRANSFORMER:

1. Copper losses:

The energy is lost in the form of heat due to resistance in the copper coils. Using the thick wires in the coils the energy losses can be reduced.

2. Eddy Current losses:

Some current is induced in the soft iron core of transformer. Eddy current causes heating effect in the core.

To minimize this energy loss soft iron core is laminated.

3. Flux leakage:

Some of magnetic field lines may escape to the surroundings as they travel through the soft iron core. This loss is called as flux leakage. The soft iron casing around the structure of transformer reduced the flux leakage.

Advantages of high voltage transmission:

One of the problems in the transmission of electrical energy is the power loss. This loss should be minimized for more efficiency and economy.

One solution is to use the thick cables so that resistance R is low. Then the power lost as heat in the cables will be a minimum.

Other solution is to reduce current I by using step up transformer. At higher voltage, current is kept low. So the electrical power loss $P=I^2R$ is reduced. Hence electrical power can be transmitted more economically at high voltage and at low current.

Advantage of A.C. for Power Transmission:

A.C., rather than D.C., is normally used for long distance power transmission because transformers make it possible to change the voltage. D.C voltages can be changed, but the process is relatively difficult and expensive. Transformers of course will not work with D.C.

Read & Write Publications
For Books Order: 0336-531411

UNIT 23

Electrons

**O Level
Physics Teacher's Notes**

**M. A. Chaudhary
Cell: 0300-9412902**

Syllabus 2017 – 18

Electrons

- Thermionic Emission
- Cathode Ray Oscilloscope C.R.O
- Calculations from C.R.O Trace

Unit-23 ELECTRONS

THERMIONIC EMISSION:

It is emission of electrons from metal filament, as heated by passing current. Since there are large number of free electrons in metals, when current is passed through the metal filament then due to resistance, heating effect is produced. The free electrons gain energy and emit out from filament. This effect is called thermionic emission or Edison effect.

Demonstration of Thermionic Emission:

When the metal filament is heated by passing low a.c. then due to heating effect electrons are emitted out from the filament. The electrons are accelerated due to positively charged anode.

Deflection by electric field:

When an electron beam passes between two charged plates, it can be observed that the electrons are deflected towards the positive plate. The electrons are attracted by the positive charges on the positive plate and repelled by the negative charges on the negative plate.

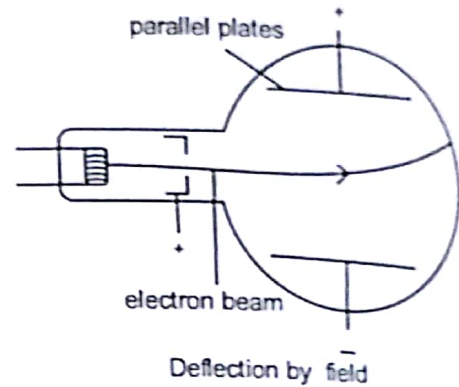

Deflection by magnetic field:

When an electron beam passes between two poles of the magnet, it can be observed that electron beam is deflected by the magnetic field. By applying Fleming's Left-hand Rule, it is observed that electron beam deflects downwards.

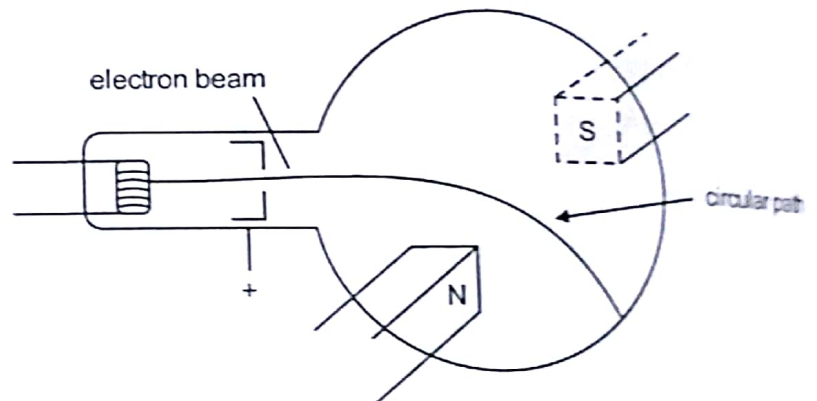

CATHODE RAY OSCILLOSCOPE C.R.O:

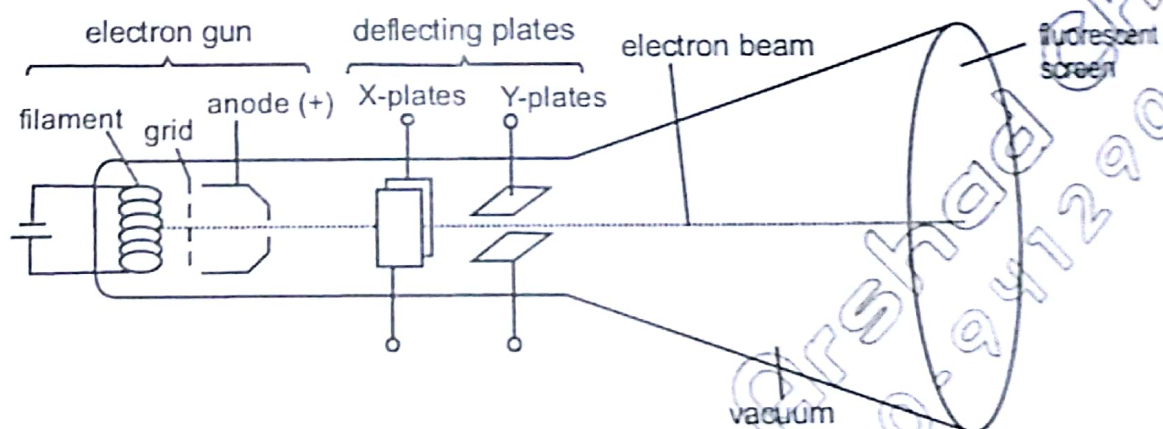





Basic Components of C.R.O

The Cathode Ray Oscilloscope consists of the following components:

- The electron gun
- The deflecting plates
- A fluorescent screen

The detail of each part of C.R.O is described below.

- 1) **Filament:**
It is heated by passing low a.c. The electrons are emitted out from the filament by thermionic emission.
- 2) **Grid:**
The negatively charged grid makes the emitted electrons into a beam. Moreover, it controls the number of electrons reaching on the screen.
- 3) **Anode:**
The positively charged anode is used to accelerate the electrons.
- 4) **Function of X and Y plates:** The function of X and Y Plates can be described in the form of table

| X-Plates | Y-Plates | Trace on Screen |
|----------|----------|---|
| OFF | OFF | dot  |
| ON | OFF | horizontal line  |
| OFF | ON | vertical line  |
| ON | ON | Wave  |

X-Plates:

They deflect the electron beam horizontally.

Y-Plates:

They deflect the electron beam vertically. If X and Y plates are functioning together then electron beam oscillates in the form of wave.

- 5) **Fluorescent Screen:** It is coated with some fluorescent material like Zinc Sulphide (ZnS). The electron beam glows on reaching the screen.

Uses of C.R.O:

The C.R.O can be used for:

- Measuring a.c. voltage
- Displaying voltage waveforms
- Measuring short intervals of time.

CALCULATIONS FROM C.R.O TRACE:

Voltage sensitivity or Y-gain:

It is voltage used by C.R.O trace per division. e.g. 5V/div.

Time-base value (X-gain):

It is time used by C.R.O trace per division e.g. 3 ms/div.

By using the values of voltage sensitivity and time base, the following calculations can be made:

- 1) **Peak Voltage:**
(Number of divisions in an amplitude) × (voltage sensitivity)
- 2) **Time Period:**
(Number of divisions in one cycle) × (time base value)
- 3) **Frequency:**

$$f = \frac{1}{T} \quad \text{where } T \rightarrow \text{time period in seconds.}$$

Electronic Components:

1. Potential divider
2. LDR
3. Thermistor
4. Diode
5. Capacitor
6. Resistor and their Colours

1) Potential divider:

It is the device used to vary the potential, according to the requirement in the circuit. e.g. rheostat, LDR, thermistor are the potential dividers.

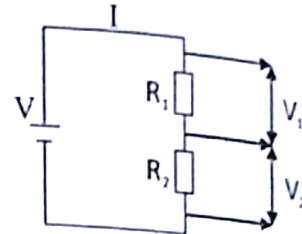

The voltage or potential difference across the given resistance can be calculated by the formulae:

$$V_1 = \left(\frac{R_1}{R_1 + R_2}\right)V, \text{ where } V_1 \text{ is the potential across the resistance } R_1$$

$$V_2 = \left(\frac{R_2}{R_1 + R_2}\right)V, \text{ where } V_2 \text{ is the potential across the resistance } R_2$$

A potentiometer regulates the potential difference across a device. It allows the P.d to be varied from its max. value to zero. Any required fraction of the total P.d can be tapped off by adjusting the sliding contacts.

2) LDR:

LDR stands for light dependent resistor. Its symbol is 

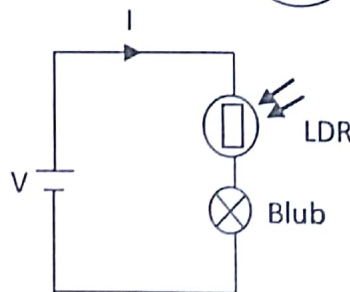

- In darkness resistance of LDR is very high so maximum voltage of battery is used across the LDR. The voltage left for bulb is very low and in brightness it happens reverse.
- In darkness, resistance of LDR is very high so it would not allow the current for bulb. In brightness, its resistance falls and it allows current for bulb.

| Light Intensity | Resistance of LDR | Current in LDR | Current in bulb |
|-----------------|-------------------|----------------|-----------------|
| Darkness | High | Low | Off |
| Brightness | Low | High | On |

3) Thermistor:

It is temperature dependent resistor. Its symbol is  It is used in fire alarms.

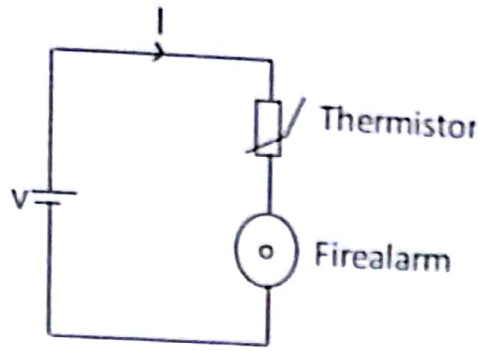

| Temperature | Resistance of Thermistor | Current in Thermistor | Current in Fire alarm |
|-------------|--------------------------|-----------------------|-----------------------|
| Low | High | Low | Off |
| High | Low | High | On |

- If temperature is low, the resistance of thermistor is high so maximum voltage of battery is used across the thermistor. The voltage left for fire alarm is very low and in brightness it happens reverse.
- If temperature is high, resistance of thermistor is low and it does not allow current for fire alarm. If temperature is high, its resistance falls and it allows current for fire alarm.

4) Diode: Its symbol is

It is used to convert a.c. → d.c. The conversion of a.c → d.c is called as rectification.

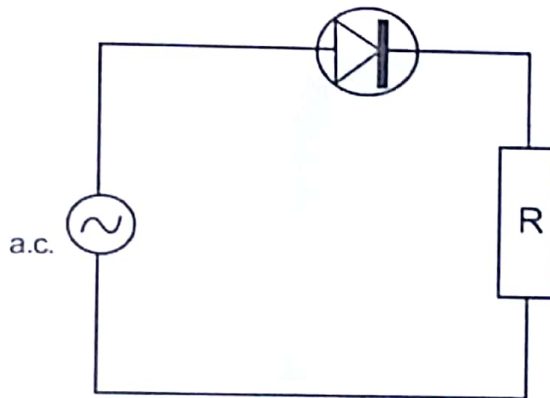

The diode conducts only positive cycles of A.C. It does not allow the negative cycles to pass through it. So a single diode produces half wave rectification, as shown in figures below.

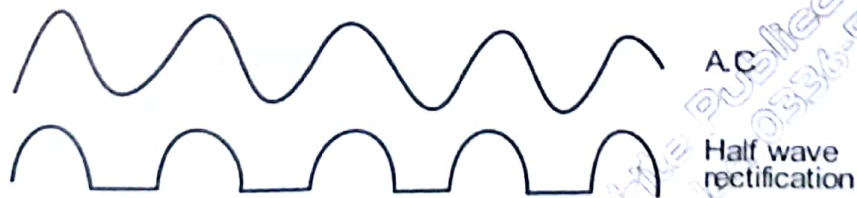

1) Capacitor:

It is used to store charge. Its symbol is

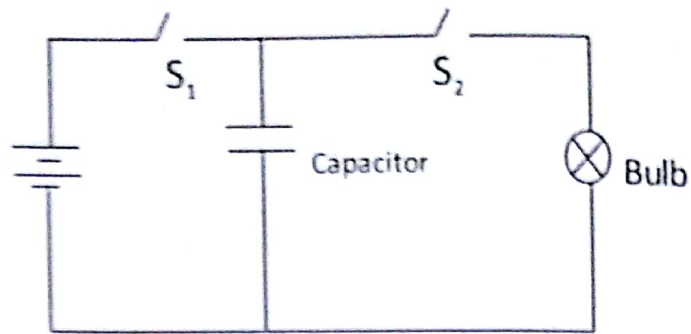

When switch S_1 is closed the capacitor takes some time for charging. When the capacitor is fully charged then switch S_1 is opened and switch S_2 is closed. The charge stored in the capacitor is released for the bulb.

5) Resistors and their colours:

The resistors are electronic components which are used to control current in a circuit. Another important consideration for the use of resistors is the power rating. The power rating of a resistor is the maximum rate of dissipation of electrical energy as heat before it is damaged. A power rating of 0.25W to 1W is normally suitable for use in most circuits.

Resistors have multicolour bands.

| Colour band | Colour code value |
|-------------|-------------------|
| Black | 0 |
| Brown | 1 |
| Red | 2 |
| Orange | 3 |
| Yellow | 4 |
| Green | 5 |
| Blue | 6 |
| Violet | 7 |
| Grey | 8 |
| White | 9 |

First Colour → write down colour code value.

Second Colour → write down colour code value.

Third Colour → write number of zeroes of colour code value.



i.e Resistance = 5700Ω

UNIT 24

Radioactivity

**O Level
Physics Teacher's Notes**

**M. A. Chaudhary
Cell: 0300-9412902**

Syllabus 2017 – 18**Radioactivity**

- Structure of an atom
- Basic terms of an atom
- Geiger Marsden experiment for discovery of nucleus
- Changes on nucleus by emission of α , β and γ
- Geiger Muller-Tube
- Star Formation

Unit-24 RADIOACTIVITY

STRUCTURE OF AN ATOM:

Key points:

- The smallest part of an element is called an atom.
- The central part of an atom is called nucleus.
- The nucleus consists of protons and neutrons. The proton is a positively charge particle. So a nucleus carries a positive charge.
- The electrons revolve around the nucleus in nearly circular orbits.
- Since an atom is neutral, so the number of electrons in an atom is equal to the number of protons.

BASIC TERMS OF AN ATOM

- Atomic number (Z).
- Mass number (A).
- Isotopes.

Atomic Number (Z):

It is the number of protons or number of electrons in an atom.

Mass Number or Nucleon Number (A):

It is the sum of protons and neutrons in an atom.

The symbol of an atom with its atomic number and mass number is:

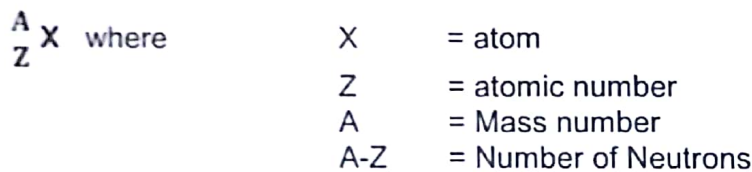

e.g. ${}_{92}^{238}\text{U}$

| | |
|-------------------------------|-------|
| Number of Protons | = 92 |
| Number of Electrons | = 92 |
| Total number of all particles | = 330 |
| Total number of neutrons | = 146 |

Isotopes:

They are atoms of the same element with the same atomic number but different mass number. Isotopes differ in the number of neutrons in their nuclei, although they have the same number of protons, with equal number of orbiting electrons.

Examples of Isotopes:

- 1) Hydrogen: ${}^1_1\text{H}, {}^2_1\text{H}, {}^3_1\text{H}$
- 2) Carbon: ${}^{12}_6\text{C}, {}^{14}_6\text{C}$
- 3) Chlorine: ${}^{35}_{17}\text{Cl}, {}^{37}_{17}\text{Cl}$

GEIGER MARS DEN EXPERIMENT FOR DISCOVERY OF NUCLEUS:

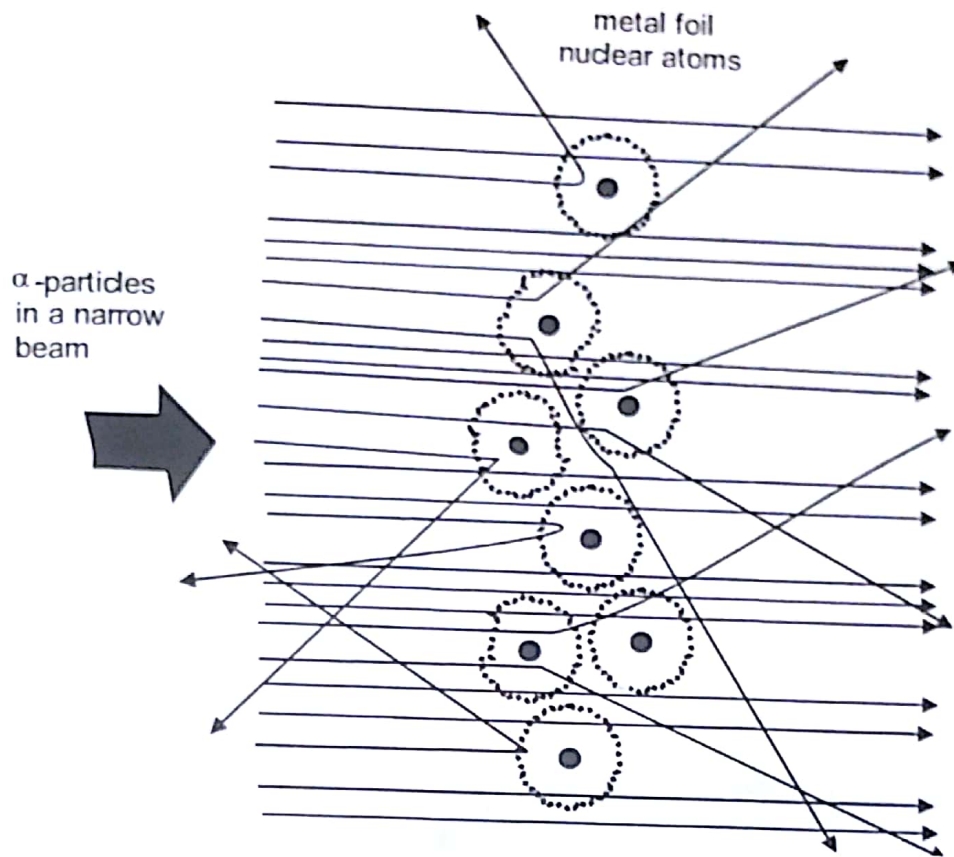

When Alpha particles are bombarded on a thin gold foil, then most of them pass straight through the foil. Few Alpha particles are deflected at certain angles. The results of experiment are:

- i) Major part of an atom is empty.
- ii) Central portion of an atom (called as nucleus) carries positive charge.
- iii) The size of nucleus is negligible as compared to size of an atom.

Radioactivity:

Radioactivity is the spontaneous and random emission of radiations from unstable nuclei. The radiations emitted are α , β and γ . The characteristics of α , β and γ are described in the table below.

Need & Write Publications
For Books Order: 0336-5314141

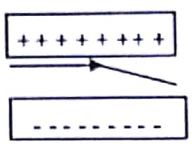
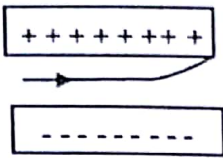
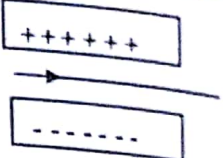
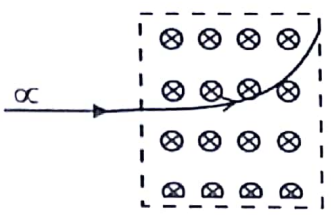
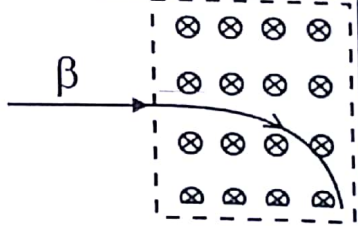
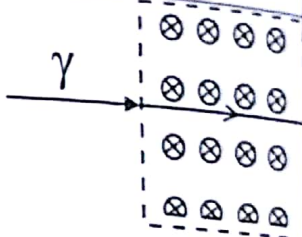
| Characteristics | Alpha - α | Beta - β | Gamma - γ |
|--------------------------|--|--|---|
| Nature | ${}^4_2\text{He}$ nucleus | Electrons | Electromagnetic radiation |
| Charge | +2 | -1 | 0 |
| Mass | 4 a.m.u | $\frac{1}{1840}$ a.m.u | 0 |
| Atomic Number | 2 | -1 | 0 |
| Mass Number | 4 | 0 | 0 |
| Penetration | Least penetration. It can pass through air up to 5cm. It can be stopped by paper. | Medium penetration. It can be stopped by Aluminium sheet of thickness of 5mm. | Maximum penetration. It can be stopped by thick lead sheet. |
| Ionizing Effect | Maximum ionization due to its large charge and mass. | Medium ionization due to its small charge and mass. | Negligible ionization, because it has neither mass nor charge. |
| Effect of electric field |  <p>α deflects less because it is a massive particle.</p> |  <p>β deflects more because it is a lighter particle.</p> |  <p>Undeflected, because it does not carry any charge.</p> |
| Effect of magnetic field |  |  |  |

CHANGES ON NUCLEUS BY EMISSION OF A, B AND γ

1. α -emission:

When α -emits from radioactive nucleus, the atomic number of daughter nucleus decreases by 2 and mass number by 4. i.e.

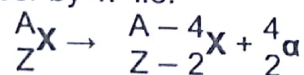

e.g.

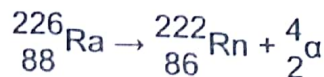

2. β -emission:

When β -emits from radioactive nucleus, the atomic number is increased by 1 and there is no change in mass number.

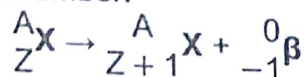

e.g.

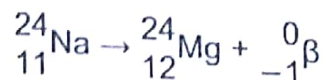

3. γ -emission:

When γ -emits from radioactive nucleus, then neither atomic number nor mass number changes. i.e.



e.g.

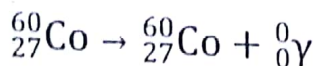

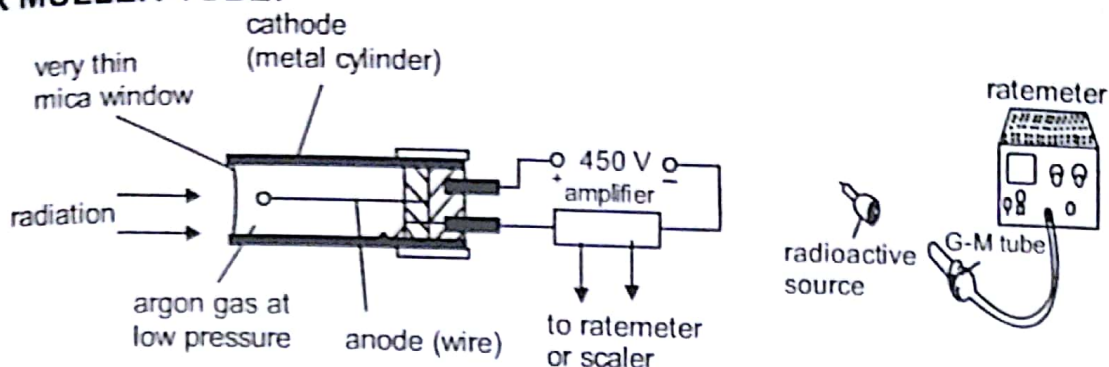
GEIGER MULLER-TUBE:

When radiations enter into GM tube, they cause ionization in the gas contained by the tube. The number of ions produced per unit time is measured by rate-meter in the form of count rate.

- (i) The presence of α -radiations is detected by placing a paper sheet between radioactive source and the tube. If the count rate falls, then α -radiations are emitted from the source which have been stopped by the paper. If count rate remains same, then source may be emitting β and γ radiations.
- (ii) Similarly, the emission of β and γ radiations can be detected by placing Al and Pb sheets respectively.

Background radiations:

The count rate of a GM tube never comes to zero due to the presence of background radiations. The sources of background radiations are:

- i) Cosmic rays; coming from outer space.
- ii) Polluted air and polluted water.
- iii) Nuclear reactor in the surrounding.
- iv) Earth's crust may contain radioactive source.

The presence of background radiations is noted before measuring the count rate with GM tube and then subtracted from the final measurements. The value of background radiations varies between 20 to 50 per minute.

Define:

- Radioactive decay.
- Spontaneous decay.
- Random decay.

➤ Radioactive decay:

The spontaneous and random emission of radiations from unstable nuclei is called radioactive decay.

➤ Spontaneous decay:

The radiations emit by their own, from the unstable nuclei. The emission of radiations is not affected by any external changes like temperature, pressure, electric and magnetic fields etc. Such emission of radiations, which is not dependent on external factors, is called spontaneous decay.

➤ Random Decay:

Radioactive emission occurs randomly over space and time. In other words, it is impossible to state exactly which nucleus and exactly when a particular nucleus will decay. The fluctuating count rate of GM tube determines the random decay.

Half-Life ($T_{1/2}$):

"The half life of a sample of radioactive substance is defined as the time taken for half of the unstable nuclei to decay."

For example if N is the number of original radioactive nuclei, and $\frac{N}{2}$ is half the number of original radioactive nuclei remaining, hence the time taken for N Nuclei to decay until $\frac{N}{2}$ nuclei are left behind is

called the half-life $T_{1/2}$. Therefore the time taken to decay to $\frac{N}{4}$ will be two half-lives i.e. $2T_{1/2}$ and so on, i.e.

$$N \xrightarrow{T_{1/2}} \frac{N}{2} \xrightarrow{2T_{1/2}} \frac{N}{4} \xrightarrow{3T_{1/2}} \frac{N}{8} \text{ and so on}$$

Half-life from decay curves:

The number of radioactive nuclei decrease exponentially with time. The exponent decrease of nuclei is given in decay curve.

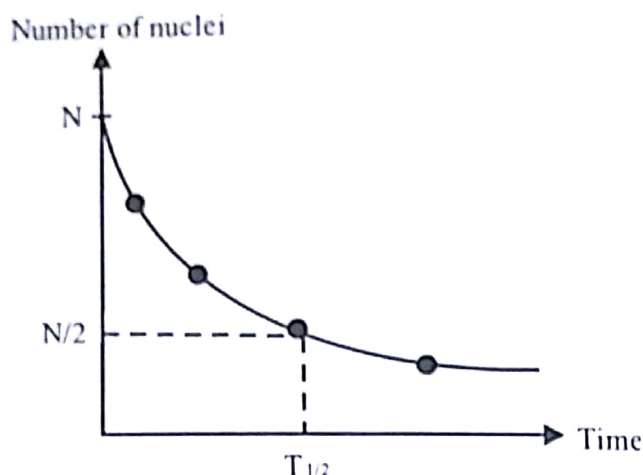

Read the time from graph, during which radioactive nuclei decay to half the original value ($N/2$). This time gives the value of half-life ($T_{1/2}$)

Precautions of handling radioactive sources/radiations:

To prevent exposure to radiations, the following precautions need to be taken:

- 1) Store the radioactive material in a lead box
- 2) Wear the lead lined gloves and suits in the radioactive lab.
- 3) Shift the radioactive material with tongs and forceps.
- 4) Avoid drinking and eating during the lab experiment with radioactive nuclei.
- 5) Hang the radioactive precautionary symbols in the region where radiations are present.



Radiation symbol

Uses of radioactivity:

1. For sterilizing medical instruments, as the bacteria and viruses are killed on exposure to γ - radiations.
2. The radiations are used as a tracer in medical as well as in industry. For example tracer elements are used to check thyroid glands and brain tumor, wear and tear of moving parts of machinery, leakage of water from underground water pipes etc.
3. Deep penetration of γ -rays is used to detect faults in welding, inside cracks of machines or engines etc. The γ -rays are also used to check the thickness of rolled sheets of metal, paper or plastic.
4. Due to the fission process of Uranium, electrical energy is produced in the nuclear reactors.
5. Cobalt decays with the emission of β and γ -rays. These radiations are used to kill the cancerous cells.

6. Radioactive Carbon-14 is present in small amounts in the atmosphere. Living plants absorb Carbon-14 and therefore become slightly radioactive. When a tree decays, the radioactive carbon present inside it will begin to decay. By measuring the activity of Carbon-14, the age of archeological findings can be determined. The procedure is called carbon dating.

Einstein's mass energy equation:

The mass can be changed into energy and energy can be changed into mass, i.e. mass and energy are interchangeable by the equation.

$$E = mc^2$$

Where

m = decrease in mass.

C = speed of light = 3×10^8 m/s.

E = energy produced.

Nuclear Fission:

'The splitting up of a heavy nucleus into two lighter nuclei, with the release of energy is called fission.'
The fission reaction is described by the equation:

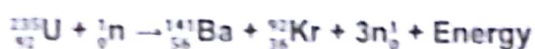

- The total mass of product particles on the right hand side of equation is less than the mass of particles on the left hand side of equation. According to Einstein mass-energy equation $E=mc^2$, the decrease in the mass is converted into energy.
- When neutron is bombarded with heavy nucleus of U, then U splits into lighter nuclei Ba & Kr and huge amount of energy is released.

Nuclear Fusion:

'The fusing up of two lighter nuclei to produce a heavy nucleus with the release of energy'
The fusion reaction is described by the equation:

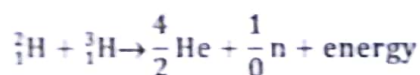

- In sunlight nuclei of hydrogen fuse together to produce heavy Helium nucleus and huge amount of energy is released.
- Fusion occurs only in the sun and stars because a temperature of approximately 100 million°C is required to overcome strong forces of repulsion between the nuclei.

Fission Reactor for use in a Power station

Key points:

- In nuclear reactors, by the fission of Uranium nuclei huge amount of nuclear energy is obtained in the form of heat
- The heat produced in the nuclear reactor, is used to produce steam in the boilers.
- The steam is then used to drive turbine.
- The turbine rotates the generator, which produces electricity.

The block diagram of electricity generation is described:

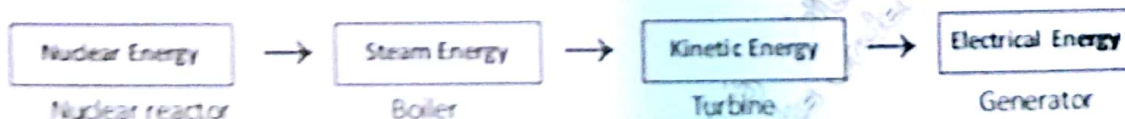

STAR FORMATION:



A star is formed out of cloud of cool, dense molecular gas. In order for it to become a potential star, the cloud needs to collapse and increase in density.

There are two common ways this can happen: it can either collide with another dense molecular cloud or it can be near enough to encounter the pressure caused by a giant supernova. Several stars can be born at once with the collision of two galaxies. In both cases, heat is needed to fuel this reaction, which comes from the mutual gravity pulling all the material inward.

What happens next is dependent upon the size of the newborn star; called a protostar. Small protostars will never have enough energy to become anything but a brown dwarf (think of a really massive Jupiter). A brown dwarf is sub-stellar object that cannot maintain high enough temperatures to perpetuate hydrogen fusion to helium. Some brown dwarfs can technically be called stars depending upon their chemical composition, but the end result is the same; it will cool slowly over billions of years to become the background temperature of the universe.

Medium to large pro stars can take one of two paths depending upon their size: if they are smaller than the sun, they undergo a proton-proton chain reaction to covert hydrogen to helium. If they are larger than the sun, they undergo a carbon-nitrogen-oxygen cycle to convert hydrogen to helium. The difference is the amount of heat involved. The **CNO** cycle happens at a much higher temperature than the p-p chain cycle.

Whatever the route – a new star has formed.

The life cycle of a star is dependent upon how quickly it consumes hydrogen. For example, small, red dwarf stars can last hundreds of billions of years, while large super giants can consume most of their hydrogen with comparably short few million years. Once the star has consumed most its hydrogen, it has reached its mature state. This is how a star forms.

M. Arshad Ch.
0300-9412902