



# LIFEGROUP LEADER TRAINING

A blue-tinted background image showing a group of people sitting around a table, engaged in a meeting or training session. A woman with glasses is on the left, and a man is on the right holding a tablet. Other people are partially visible in the background.

NEW LEADER ORIENTATION

AUTHENTIC COMMUNITY –  
**WE BELIEVE THAT  
GOD WANTS US  
TO BE CONNECTED TO  
EACH OTHER...  
NOT ISOLATED FROM  
EACH OTHER**

## **LIFEGROUP PURPOSE**

The Purpose of Lifegroups is to get people connected and to help them take a next step in their spiritual journey.

What does it mean to get connected? Who are we connecting to?

What does a next step in someone's spiritual journey look like?  
Give examples.

## **LIFEGROUP STRUCTURE**

Our model is designed or structured in a way that fosters an environment of discipleship. Consistency in a Lifegroup helps nurture discipleship relationships. As Lifegroup Leaders, we ask that you encourage people to seek and pursue Christ.

What does discipleship mean?

Who has the responsibility of discipleship within the group?

If we are leading others to learn from and live like Jesus, then what should naturally happen in your group?

Never \_\_\_\_\_.  
Delegate the Core Values.

**Lifegroup naturally encourages connectivity and consistency through Lifegroup Strategies:**

- Term Breaks
- Lifegroup Launch
- Study Selection
- 6 Components of a Lifegroup

How many terms are in a year?

Why do we do term breaks?

What does a Lifegroup Launch look like?

How do you select a study for the upcoming term?

What does it mean to update your roster and update your catalog information?

What is the Lifegroup Leader eNews and Leadercast?

## TERM SCHEDULE EXAMPLE

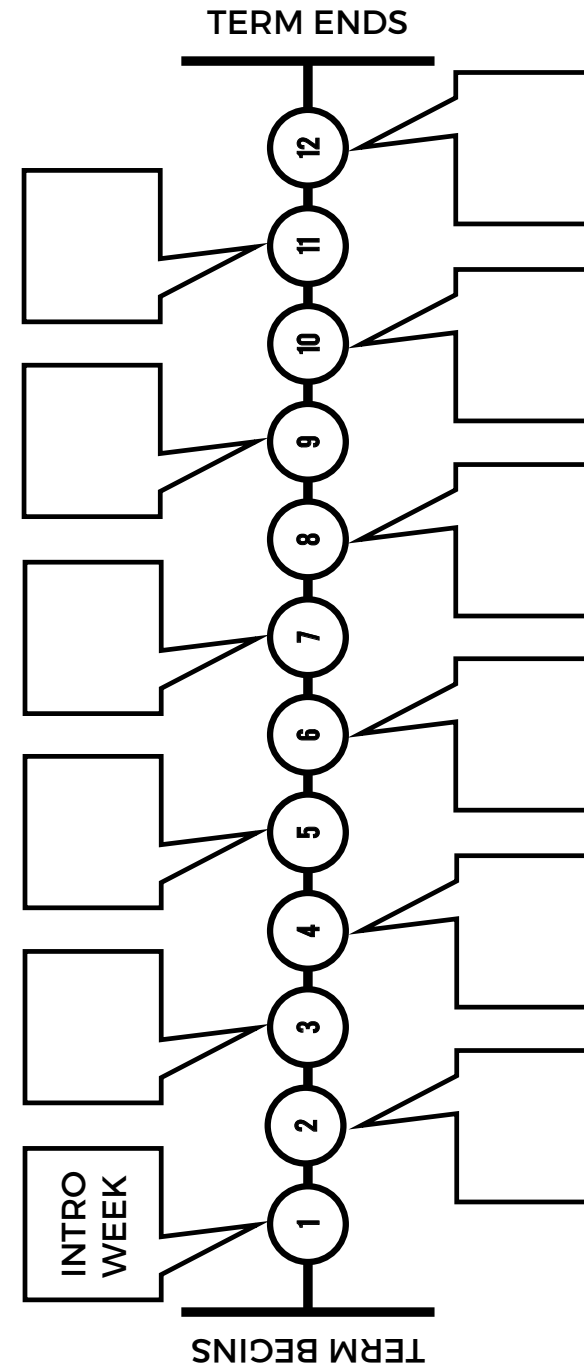

## WHAT ARE THE SIX COMPONENTS OF LIFEGROUP?

**F**\_\_\_\_\_

Creating an environment of open dialogue helps your members be more comfortable speaking to and with the other members of group.

**W**\_\_\_\_\_

Recognizing the power and majesty of God and declaring who He is. Whenever we encounter God, worship is the response.

**F**\_\_\_\_\_

Focusing on the application of what God is teaching you leads to Lifechange. An open discussion is important, as everyone should have the opportunity to share what God is teaching them through God's Word. What is the difference between facilitation and teaching? How do you ensure that all members of the group are actively participating in the discussion?

**P**\_\_\_\_\_

Used as a ministry and not necessarily just the opening and closing times of the group. Focusing on God and his priorities.

**W**\_\_\_\_\_

We have a biblical responsibility to invest in the next generation through a safe, social, and learning environment for our kids.

**S**\_\_\_\_\_ **T**\_\_\_\_\_ **C**\_\_\_\_\_

Lifepoint's core value of Reaching Priority is accomplished locally through our Lifegroups. Each group forms a partnership with a local mission, so we can be the hands and feet of Christ and share the Gospel within our local community.

## LEADERSHIP STRUCTURE

Our Span of Care model helps us to make sure that everyone is cared for.

We have a Lead Pastor, a Campus Life Pastor, a system of Coaches, our Lifegroup Leaders, and then our Lifegroups. Each person in our leadership structure will minister two levels down. We ask for them to know the details in the lives of those one level down and to loosely know the details two levels down.

We ask that significant life events are communicated to the Coach and Campus Life Pastor so that we can celebrate, support, and pray with you. Each of our leaders look out for one another, so letting the other Lifegroup Leaders know how they can serve in practical ways in important.

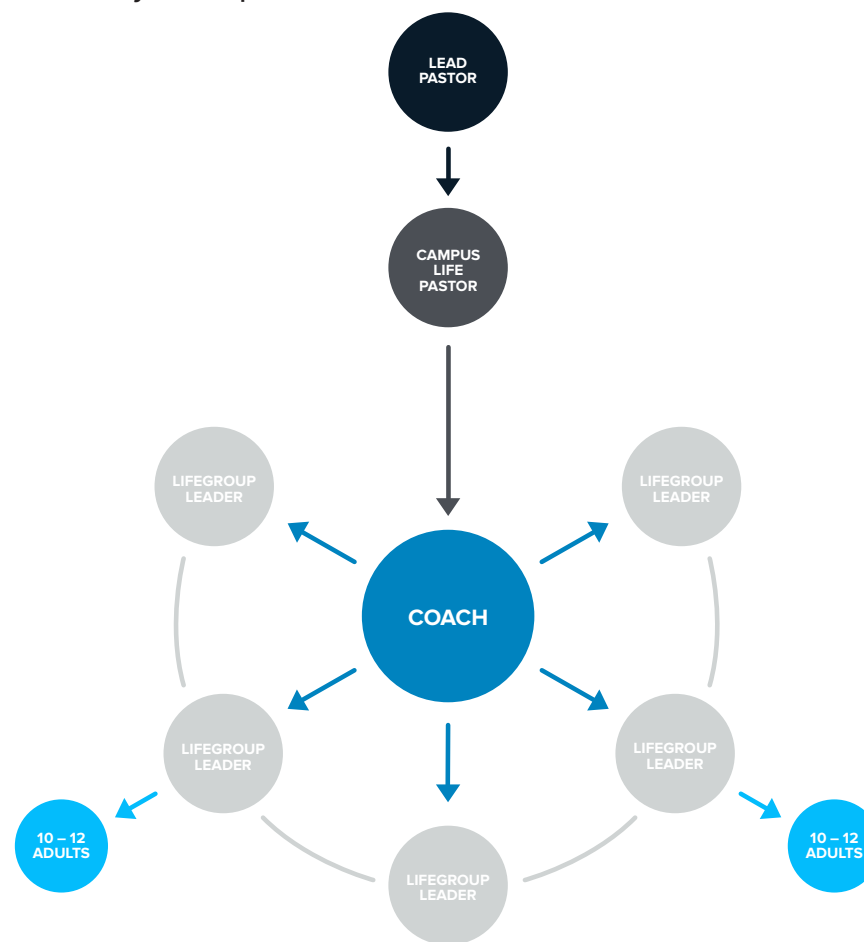

## COACHING STRUCTURE

Each lifegroup leader will work with a Campus Life Pastor and Coach who will help equip and assist them with their lifegroup.

- Paired with a Lifegroup Coach as your first point of contact
- Coach will connect with you through Coaching Huddle two times per term, typically 4th and 10th week of term
- Meet with Coach and other lifegroup leaders at least twice per year
- Help you navigate difficult situations within the group
- Coaches are there to celebrate and pray with you
- Coaches will partner with you around ongoing development

## LIFEGROUP LEADER EXPECTATIONS

To ensure the health of our groups there are certain expectations of a lifegroup leader at Lifepoint.

- Have a personal growing relationship with Christ
- Be a member of Lifepoint Church by completing the membership process and actively live out Lifepoint's Core Values and Beliefs
- Faithfully attend Lifepoint worship gatherings
- Be willing to follow the vision and leadership team of Lifepoint Church
- If married, have your spouse's support for your role as lifegroup leader
- Guard personal integrity. Use your platform wisely.
- Empower those within your Lifegroup by never leading alone

*Additional New Leader Video Resources can be found at [www.lifepointohio.com/ministries/lifegroups/leaders](http://www.lifepointohio.com/ministries/lifegroups/leaders). Please take the time to watch these videos after orientation, to understand the full scope of our Lifegroup Structure.*

Notes:

---

---

---

---

---

---

---

---

---

---

---

---

---

---

---

---

---

---

---

---

---

---

---

**Notes:**

---

---

---

---

---

---

---

---

---

---

---

---

---

---

---

---

---

---

---

---

---

---

---



**ONE CHURCH – MANY LOCATIONS**

