



# A Level Physics Knowledge Organiser

Physics (Walsall Academy)

# AS Physics

## Unit 2

1 Scalars and Vectors

2 Resolving Vectors

## Unit 3

### Mechanics and Materials

4 Velocity and Acceleration

5 Motion Graphs

6 Equations of Motion

7 Terminal Velocity and Projectiles

3 Moments

9 Work, Energy and Power

10 Conservation of Energy

11 Hooke's Law

12 Stress and Strain

13 Bulk Properties of Solids

14 Young's Modulus

1 Momentum and Collisions

8 Newton's Laws

2 Force and Impulse

## Unit 4

### Particles, Quantum Phenomena Electricity

#### and Waves

13 QVIRt

14 Ohm's Law and I-V Graphs

15 Resistivity and Superconductivity

16 Series and Parallel Circuits

17 Energy and Power

18 EMF and Internal Resistance

19 Kirchhoff and Potential Dividers

20 Alternating Current

21 The Oscilloscope

15 Progressive Waves

16 Longitudinal and Transverse Waves

17 Superposition and Standing Waves

18 Refraction

19 Total Internal Reflection

20 Interference

21 Diffraction

10 The Photoelectric Effect

11 Excitation, Ionisation and Energy Levels

12 Wave Particle Duality

Unit 2	Mr Shepherd <b>Scalars and Vectors</b>	
Learning Outcomes	To know the difference between scalars and vectors and be able to list some examples of each	
	To be able to add vectors by scale drawing	
	To be able to add negative vectors by scale drawing	

### What is a Vector?

A vector is a physical quantity that has both magnitude (size) and direction.

**Examples of Vectors:** Displacement, velocity, force, acceleration and momentum.

### What is a Scalar?

A scalar is a physical quantity that has magnitude only (it doesn't act in a certain direction).

**Examples of Scalars:** Distance, speed, energy, power, pressure, temperature and mass.

### Vector Diagrams

A vector can be represented by a vector diagram as well as numerically:

The length of the line represents the magnitude of the vector.

The direction of the line represents the direction of the vector.

We can see that vector **a** has a greater magnitude than vector **b** but acts in a different direction.

A negative vector means a vector of equal magnitude but opposite direction.

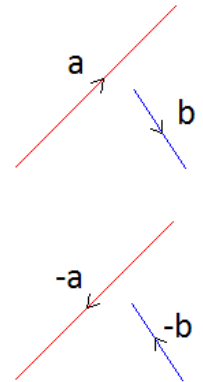

### Adding Vectors

We can add vectors together to find the affect that two or more would have if acting at the same time. This is called the resultant vector. We can find the resultant vector in four ways: Scale drawing, Pythagoras, the Sine and Cosine rules and Resolving vectors (next lesson).

### Scale Drawing

To find the resultant vector of **a + b** we draw vector **a** then draw vector **b** from the end of **a**. The resultant is the line that connects the start and finish points.

The resultants of **a + b**, **b - a**, **a - b**, **-a - b** and would look like this:

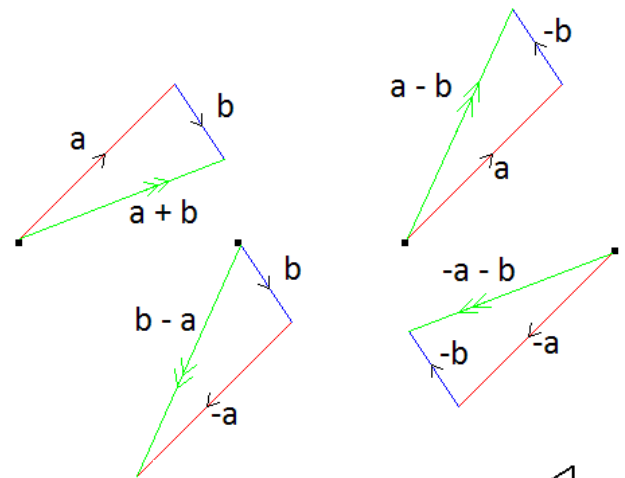

If the vectors were drawn to scale we can find the resultant by measuring the length of the line and the angle.

### Pythagoras

If two vectors are perpendicular to each other the resultant can be found using Pythagoras:

Vector **z** is the resultant of vectors **x** and **y**.

Since **x** and **y** are perpendicular  $z^2 = x^2 + y^2 \rightarrow z = \sqrt{x^2 + y^2}$

We can also use this in reverse to find **x** or **y**:

$$z^2 = x^2 + y^2 \rightarrow z^2 - y^2 = x^2 \rightarrow \sqrt{z^2 - y^2} = x$$

$$z^2 = x^2 + y^2 \rightarrow z^2 - x^2 = y^2 \rightarrow \sqrt{z^2 - x^2} = y$$

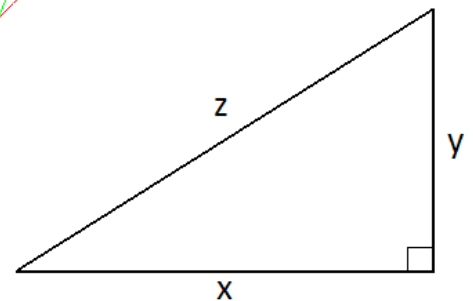

### Sine and Cosine Rules

The sine rule relates the angles and lengths using this equation:

$$\frac{\sin A}{a} = \frac{\sin B}{b} = \frac{\sin C}{c}$$

The Cosine rule relates them using these equations:

$$a^2 = b^2 + c^2 - 2bc \cos A$$

$$b^2 = a^2 + c^2 - 2ac \cos B$$

$$c^2 = a^2 + b^2 - 2abc \cos C$$

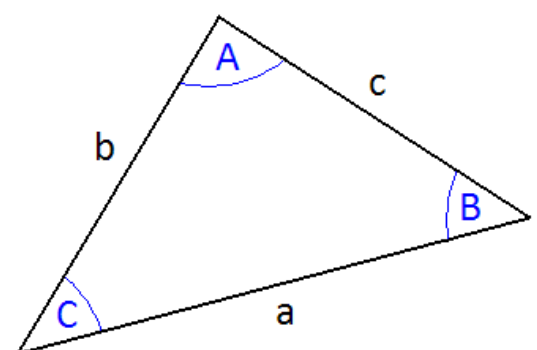

Unit 2	Mr Shepherd <b>Resolving Vectors</b>	
Learning Outcomes	To be able to resolve vectors into their vertical and horizontal components	
	To be able to add vectors and find the resultant by resolving them	
	To know what equilibrium is and how it is achieved	

In the last lesson we looked at how we could add vectors together and find the resultant. In this lesson we will first look at 'breaking down' the vectors and then finding the equilibrium.

### Resolving Vectors

A vector can be 'broken down' or *resolved* into its vertical and horizontal components.

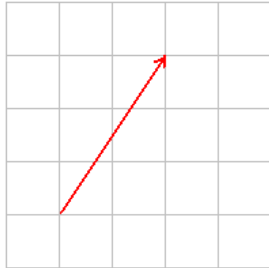

We can see that this vector can be resolved into two perpendicular components, in this case two to the right and three up. This is obvious when it is drawn on graph paper but becomes trickier when there isn't a grid and still requires an element of scale drawing.

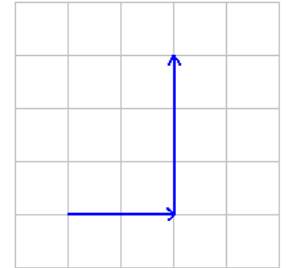

We can calculate the vertical and horizontal components if we know the magnitude and direction of the vector. In other words; we can work out the across and upwards bits of the vector if we know the length of the line and the angle between it and the horizontal or vertical axis.

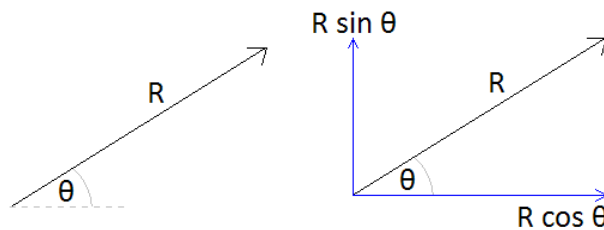

### Adding Resolved Vectors

Now that we can resolve vectors into the vertical and horizontal components it is made from we can add them together. Look at this example of multiple vectors acting (A).

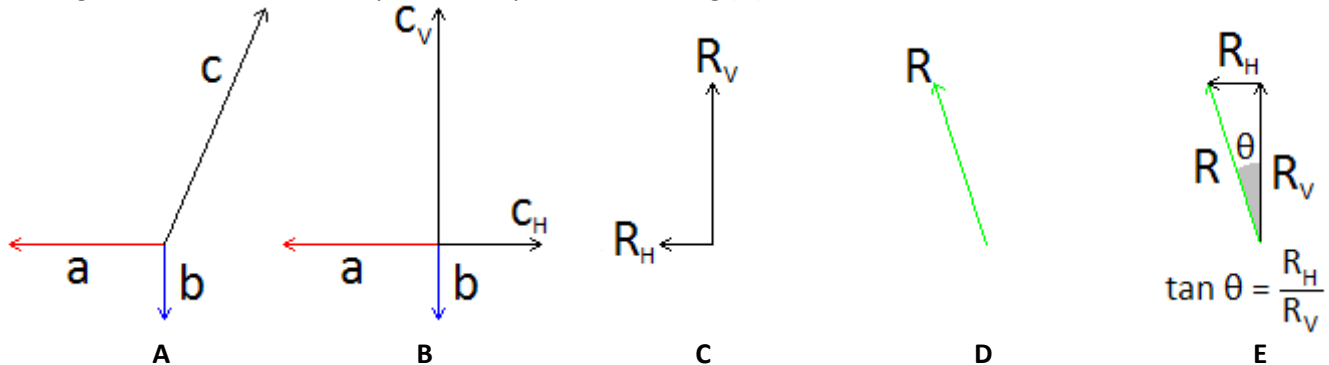

If we resolve the vector **c** we get (B). We can now find the resultant of the horizontal components and the resultant of the vertical components (C). We can then add these together to find the resultant vector (D) and the angle can be found using trigonometry (E)

### Equilibrium

When all the forces acting on a body cancel out equilibrium is reached and the object does not move. As you sit and read this the downwards forces acting on you are equally balanced by the upwards forces, the resultant it that you do not move.

With scale drawing we can draw the vectors, one after the other. If we end up in the same position we started at then equilibrium is achieved.

With resolving vectors we can resolve all vectors into their vertical and horizontal components. If the components up and down are equal and the components left and right are equal equilibrium has been reached.

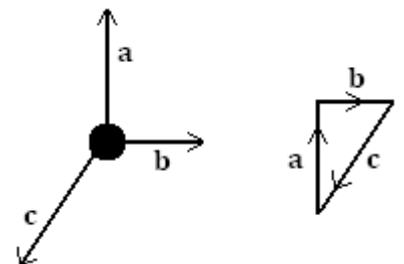

Unit 4	Mr Shepherd	
	<b>QVIRt</b>	
Learning Outcomes	To be able to explain what current, charge, voltage/potential difference and resistance are	
	To know the equations that link these	
	To know the correct units to be use in each	

## Definitions (Also seen in GCSE Physics 2)

### Current, $I$

Electrical current is the rate of flow of charge in a circuit. Electrons are charged particles that move around the circuit. So we can think of the electrical current is the rate of the flow of electrons, not so much the speed but the number of electrons moving in the circuit. If we imagine that electrons are Year 7 students and a wire of a circuit is a corridor, the current is how many students passing in a set time.

**Current is measured in Amperes (or Amps), A**

### Charge, $Q$

The amount of electrical charge is a fundamental unit, similar to mass and length and time. From the data sheet we can see that the charge on one electron is actually  $-1.60 \times 10^{-19}$  C. This means that it takes  $6.25 \times 10^{18}$  electrons to transfer 1C of charge.

**Charge is measured in Coulombs, C**

### Voltage/Potential Difference, $V$

Voltage, or potential difference, is the work done per unit charge.

1 unit of charge is  $6.25 \times 10^{18}$  electrons, so we can think of potential difference as the energy given to each of the electrons, or the pushing force on the electrons. It is the p.d. that causes a current to flow and we can think of it like water flowing in a pipe. If we make one end higher than the other end, water will flow down in, if we increase the height (increase the p.d.) we get more flowing. If we think of current as Year 7s walking down a corridor, the harder we push them down the corridor the more we get flowing.

**Voltage and p.d. are measured in Volts, V**

### Resistance, $R$

The resistance of a material tells us how easy or difficult it is to make a current flow through it. If we think of current as Year 7s walking down a corridor, it would be harder to make the Year 7s flow if we added some Year 11 rugby players into the corridor. Increasing resistance lowers the current.

**Resistance is measured in Ohms,  $\Omega$**

### Time, $t$

You know, time! How long stuff takes and that.

**Time is measured in seconds, s**

## Equations

There are three equations that we need to be able to explain and substitute numbers into.

1

$$I = \frac{\Delta Q}{\Delta t}$$

This says that the current is the rate of change of charge per second and backs up or idea of current as the rate at which electrons (and charge) flow.

This can be rearranged into

$$\Delta Q = I\Delta t$$

which means that the charge is equal to how much is flowing multiplied by how long it flows for.

2

$$V = \frac{E}{Q}$$

This says that the voltage/p.d. is equal to the energy per charge. *The 'push' of the electrons is equal to the energy given to each charge (electron).*

3

$$V = IR$$

This says that increasing the p.d. increases the current. *Increasing the 'push' of the electrons makes more flow.* It also shows us that for constant V, if R increases I gets smaller. *Pushing the same strength, if there is more blocking force less current will flow.*

Unit 4	Mr Shepherd	
	<h1>Ohm's Laws and I-V Graphs</h1>	
Learning Outcomes	To be able to sketch and explain the I-V graphs of a diode, filament lamp and resistor	
	To be able to describe the experimental set up and measurements required to obtain these graphs	
	To know how the resistance of an LDR and Thermistor varies	

### Ohm's Law *(Also seen in GCSE Physics 2)*

After the last lesson we knew that a voltage (or potential difference) causes a current to flow and that the size of the current depends on the size of the p.d.

For something to obey Ohm's law the current flowing is proportional to the p.d. pushing it.  $V=IR$  so this means the resistance is constant. On a graph of current against p.d. this appears as a straight line.

### Taking Measurements

To find how the current through a component varies with the potential difference across it we must take readings.

To measure the potential difference we use a voltmeter connected in parallel and to measure the current we use an ammeter connected in series.

If we connect the component to a battery we would now have one reading for the p.d. and one for the current. But what we require is a *range* of readings. One way around this would be to use a range of batteries to give different p.d.s. A better way is to add a variable resistor to the circuit, this allows us to use one battery and get a range of readings for current and p.d. To obtain values for current in the negative direction we can reverse either the battery or the component.

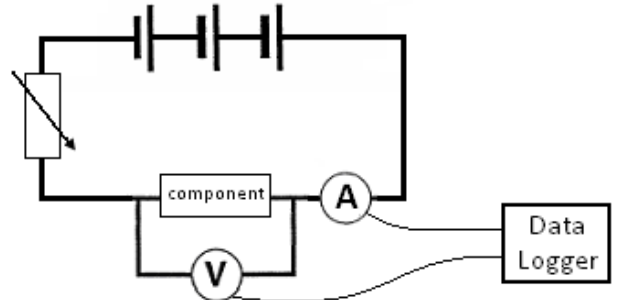

### I-V Graphs *(Also seen in GCSE Physics 2)*

#### Resistor

This shows that when p.d. is zero so is the current. When we increase the p.d. in one direction the current increases in that direction. If we apply a p.d. in the reverse direction a current flows in the reverse direction. The straight line shows that current is proportional to p.d. and it obeys Ohm's law. Graph **a** has a lower resistance than graph **b** because for the same p.d. less current flows through **b**.

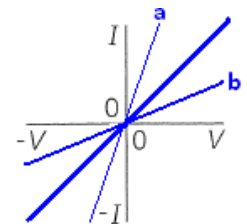

Ohmic Resistor

#### Filament Lamp

At low values the current is proportional to p.d. and so, obeys Ohm's law. As the potential difference and current increase so does the temperature. This increases the resistance and the graph curves, since resistance changes it no longer obeys Ohm's law.

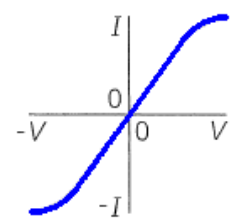

Filament Lamp

#### Diode

This shows us that in one direction increasing the p.d. increases the current but in the reverse direction the p.d. does not make a current flow. We say that it is forward biased. Since resistance changes it does not obey Ohm's law.

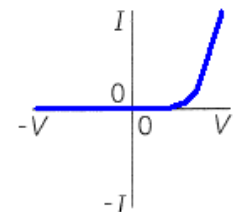

Semiconducting Diode

### Three Special Resistors *(Also seen in GCSE Physics 2)*

#### Variable Resistor

A variable resistor is a resistor whose value can be changed.

#### Thermistor

The resistance of a thermistor varied with temperature. At low temperatures the resistance is high, at high temperatures the resistance is low.

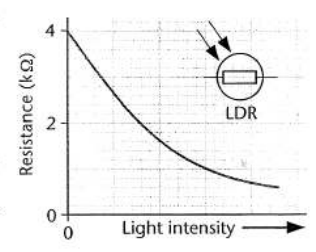
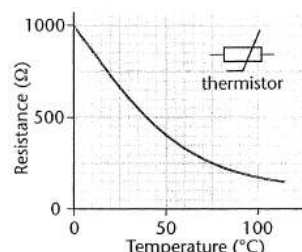

#### Light Dependant Resistor (L.D.R)

The resistance of a thermistor varied with light intensity. In dim light the resistance is high and in bright light the resistance is low.

Unit 4	Mr Shepherd	
	<h1>Resistivity and Superconductivity</h1>	
Learning Outcomes	To be able to state what affects resistance of a wire and explain how they affect it	
	To be able to describe the experimental set up required to calculate resistivity and define it	
	To be able to explain superconductivity and state its uses	

## Resistance

The resistance of a wire is caused by free electrons colliding with the positive ions that make up the structure of the metal. The resistance depends upon several factors:

### Length, $l$

The longer the piece of wire the more collisions the electrons will have.

**Length increases – resistance increases**

### Area, $A$

The wider the piece of wire the more gaps there are between the ions.

**Area increases – resistance decreases**

### Temperature

As temperature increases the ions are given more energy and vibrate more, the electrons are more likely to collide with the ions.

**Temperature increases – resistance increases**

### Material

The structure of any two metals is similar but not the same, some metal ions are closer together, others have bigger ions.

## Resistivity, $\rho$

The resistance of a material can be calculate using  $R = \rho \frac{l}{A}$  where  $\rho$  is the resistivity of the material.

Resistivity is a factor that accounts for the structure of the metal and the temperature. Each metal has its own value of resistivity for each temperature. For example, the resistivity of copper is  $1.7 \times 10^{-8} \Omega\text{m}$  and carbon is  $3 \times 10^{-5} \Omega\text{m}$  at room temperature. When both are heated to  $100^\circ\text{C}$  their resistivities increase.

**Resistivity is measured in Ohm metres,  $\Omega\text{m}$**

## Measuring Resistivity

In order to measure resistivity of a wire we need to measure the length, cross-sectional area (using  $\text{Area} = \pi r^2$ ) and resistance. Remember, to measure the resistance we need to measure values of current and potential difference using the set up shown on the right

We then rearrange the equation to  $\rho = \frac{RA}{l}$  and substitute values in

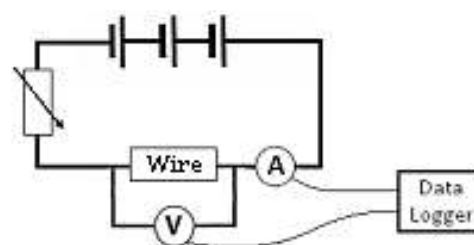

## Superconductivity

The resistivity (and so resistance) of metals increases with the temperature. The reverse is also true that, lowering the temperature lowers the resistivity.

When certain metals are cooled below a *critical temperature* their resistivity drops to zero. The metal now has zero resistance and allows massive currents to flow without losing any energy as heat. These metals are called superconductors. When a superconductor is heated above it's critical temperature it loses its superconductivity and behaves like other metals.

The highest recorded temperature to date is  $-196^\circ\text{C}$ , large amounts of energy are required to cool the metal to below this temperature.

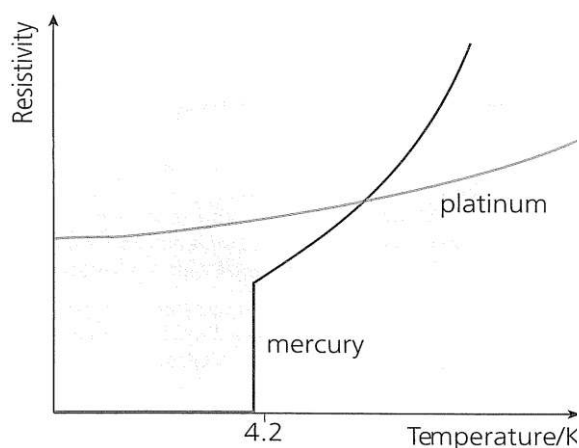

## Uses of Superconductors

- High-power electromagnets
- Power cables
- Magnetic Resonance Imaging (MRI) scanners

Unit 4	Mr Shepherd	
	<h1>Series and Parallel Circuits</h1>	
Learning Outcomes	To be able to calculate total current in series and parallel circuits	
	To be able to calculate total potential difference in series and parallel circuits	
	To be able to calculate total resistance in series and parallel circuits	

### Series Circuits (Also seen in GCSE Physics 2)

In a series circuit all the components are in one circuit or loop. If resistor 1 in the diagram was removed this would break the whole circuit.

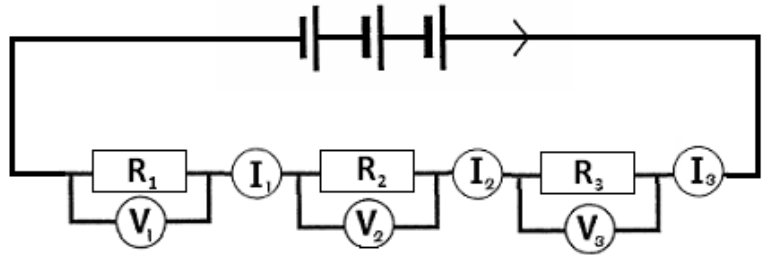

The total current of the circuit is the same at each point in the circuit.

The total voltage of the circuit is equal to the sum of the p.d.s across each resistor.

The total resistance of the circuit is equal to the sum of the resistance of each resistor.

$$I_{TOTAL} = I_1 = I_2 = I_3$$

$$V_{TOTAL} = V_1 + V_2 + V_3$$

$$R_{TOTAL} = R_1 + R_2 + R_3$$

### Parallel Circuits (Also seen in GCSE Physics 2)

Components in parallel have their own separate circuit or loop. If resistor 1 in the diagram was removed this would only break that circuit, a current would still flow through resistors 2 and 3.

The total current is equal to the sum of the currents through each resistor.

$$I_{TOTAL} = I_1 + I_2 + I_3$$

The total potential difference is equal to the p.d.s across each resistor.

$$V_{TOTAL} = V_1 = V_2 = V_3$$

The total resistance can be calculated using the equation:

$$\frac{1}{R_{TOTAL}} = \frac{1}{R_1} + \frac{1}{R_2} + \frac{1}{R_3}$$

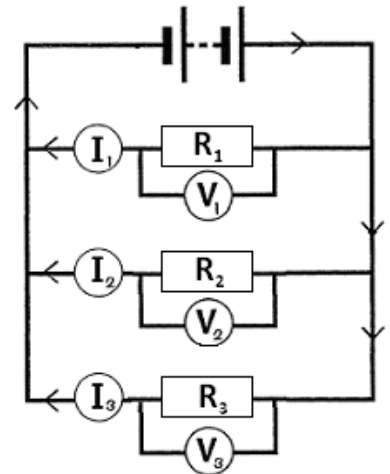

### Water Slide Analogy

Imagine instead of getting a potential difference we get a height difference by reaching the top of a slide. This series circuit has three connected slides and the parallel circuit below has three separate slides that reach the bottom.

#### Voltages/P.D.s

In series we can see that the total height loss is equal to how much you fall on slide 1, slide 2 and slide 3 added together. This means that the total p.d. lost must be the p.d. given by the battery. If the resistors have equal values this drop in potential difference will be equal.

In parallel we see each slide will drop by the same height meaning the potential difference is equal to the total potential difference of the battery.

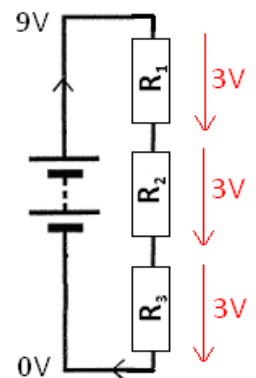

#### Currents

If we imagine 100 people on the water slide, in series we can see that 100 people get to the top. All 100 must go down slide 1 then slide 2 and final slide 3, there is no other option. So the current in a series circuit is the same everywhere.

In parallel we see there is a choice in the slide we take. 100 people get to the top of the slide but some may go down slide 1, some down slide 2 and some down slide 3. The total number of people is equal to the number of people going down each slide added together, and the total current is equal to the currents in each circuit/loop.

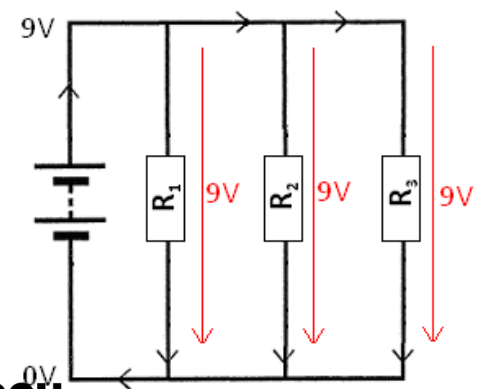



Unit 4	Mr Shepherd	
	<h1>Energy and Power</h1>	
Learning Outcomes	To know what power is and how to calculate the power of an electrical circuit	
	To know how to calculate the energy transferred in an electrical circuit	
	To be able to derive further equations or use a series of equations to find the answer	

### Power (Also seen in GCSE Physics 1)

Power is a measure of how quickly something can transfer energy. Power is linked to energy by the equation:

$$\boxed{Power = \frac{Energy}{time}}$$

**Power is measured in Watts, W**

**Energy is measured in Joules, J**

**Time is measured in seconds, s**

### New Equations

If we look at the equations from the QVIRt lesson we can derive some new equations for energy and power.

#### Energy

$V = \frac{E}{Q}$  can be rearranged into  $E = VQ$  and we know that  $Q = It$  so combining these equations we get a new

one to calculate the energy in an electric circuit:

$$E = VQ \leftarrow \dots \dots \dots Q = It \quad \text{so} \quad \boxed{E = VIt} \quad (1)$$

#### Power

If we look at the top equation, to work out power we divide energy by time:

$$\frac{E}{t} = \frac{VIt}{t} \quad \text{which cancels out to become} \quad \boxed{P = VI} \quad (2)$$

If we substitute  $V = IR$  into the last equation we get another equation for power:

$$P = IV \leftarrow \dots \dots \dots V = IR \quad \text{so} \quad \boxed{P = I^2R} \quad (3)$$

We can also rearrange  $V = IR$  into  $I = \frac{V}{R}$  and substitute this into  $P = VI$  to get our last equation for power:

$$P = VI \leftarrow \dots \dots \dots I = \frac{V}{R} \quad \text{so} \quad \boxed{P = \frac{V^2}{R}} \quad (4)$$

#### Energy again

Two more equations for energy can be derived from the equation at the top and equations 3 and 4

Energy = Power x time

$$Pt = I^2Rt \quad \text{Equation 3 becomes} \quad \boxed{E = I^2Rt} \quad (5)$$

$$Pt = \frac{V^2}{R}t \quad \text{Equation 4 becomes} \quad \boxed{E = \frac{V^2}{R}t} \quad (6)$$

### Fuses (Also seen in GCSE Physics 2)

Electrical devices connected to the Mains supply by a three-pin plug have a fuse as part of their circuit. This is a thin piece of wire that melts if the current through it exceeds its maximum tolerance. The common fuses used are 3A, 5A and 13A. A 100W light bulb connected to the UK Mains would have a 240V potential difference across it. Using  $P = IV$  we can see that the current would be 0.42A so a 2A fuse would be the best to use.

### Applications

The starter motor of a motor car needs to transfer a lot of energy very quickly, meaning it needs a high power. Millions of Joules are required in seconds; since the voltage of the battery is unchanging we need current in the region of 160A which is enormous.

The power lines that are held by pylons and form part of the National Grid are very thick and carry electricity that has a very high voltage. Increasing the voltage lowers the current so if we look at the equation

$E = I^2Rt$  we can see that this lowers the energy transferred to the surroundings.



Unit 4	Mr Shepherd	
	<h1>Kirchhoff and Potential Dividers</h1>	
Learning Outcomes	To know Kirchhoff's laws and be able to apply them to questions	
	To know what a potential divider is and be able to calculate the output voltage	
	To be able to explain an application of a potential divider	

### Kirchhoff's Laws

Kirchhoff came up with two (some may say rather obvious) laws concerning conservation in electrical circuits.

#### Captain Obvious' First Law

Electric charge is conserved in all circuits, all the charge that arrives at a point must leave it.

Current going in = current going out.

In the diagram we can say that:

$$I_1 = I_2 + I_3 + I_4$$

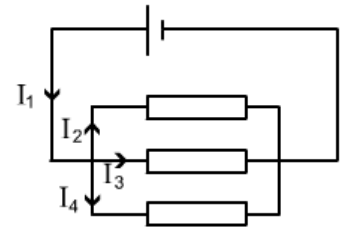

#### Captain Obvious' Second Law

Energy is conserved in all circuits, for any complete circuit the sum of the emfs is equal to the sum of the potential differences.

Energy givers = energy takers.

In the diagram we can say that:

$$\varepsilon = pd_1 + pd_2 + pd_3 + pd_4$$

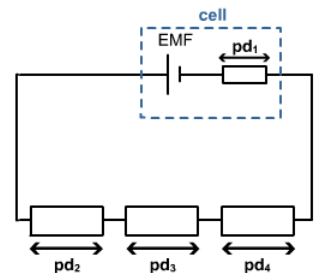

### Potential Dividers

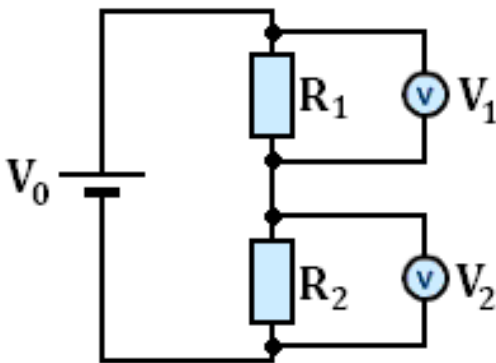

A potential divider is used to produce a desired potential difference, it can be thought of as a potential selector.

A typical potential divider consists of two or more resistors that share the emf from the battery/cell.

The p.d.s across  $R_1$  and  $R_2$  can be calculated using the following equations:

$$V_1 = V_0 \frac{R_1}{R_1 + R_2}$$

$$V_2 = V_0 \frac{R_2}{R_1 + R_2}$$

This actually shows us that the size of the potential difference is equal to the input potential multiplied by what proportion of  $R_1$  is of the total resistance.

If  $R_1$  is  $10 \Omega$  and  $R_2$  is  $90 \Omega$ ,  $R_1$  contributes a tenth of the total resistance so  $R_1$  has a tenth of the available potential. This can be represented using:

$$\frac{R_1}{R_2} = \frac{V_1}{V_2}$$

The ratio of the resistances is equal to the ratio of the output voltages.

### Uses

In this potential divider the second resistor is a thermistor. When the temperature is low the resistance ( $R_2$ ) is high, this makes the output voltage high. When the temperature is high the resistance ( $R_2$ ) is low, this makes the output voltage low. A use of this would be a cooling fan that works harder when it is warm.

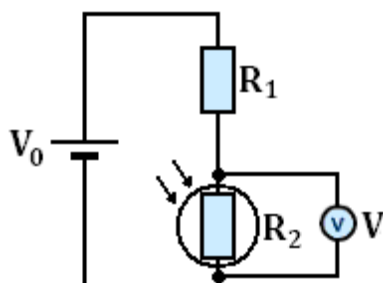
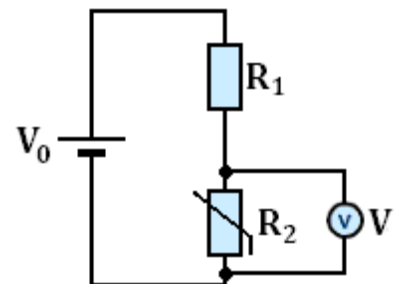

In the second potential divider the second resistor is a Light Dependant Resistor. When the light levels are low the resistance ( $R_2$ ) is high, making the output voltage high. When the light levels increase the resistance ( $R_2$ ) decreases, this makes the output voltage decrease. A use of this could be a street light sensor that lights up when the surrounding are dark.

Unit 4	Mr Shepherd	
	<h1>Alternating Current</h1>	
Learning Outcomes	To know what peak current/voltage is and to be able to identify it	
	To know what peak-to-peak current/voltage is and to be able to identify it	
	To know what r.m.s. values are and to be able to calculate them	

### ACDC Definitions (Also seen in GCSE Physics 2)

#### Direct Current

Cells and batteries are suppliers of direct current; they supply an emf in one direction.

In the graph below we can see that the current and voltage are constant. The bottom line shows that when the battery or cell is reversed the voltage and current are constants in the other direction

#### Alternating Current

The Mains electricity supplies an alternating current; it supplies an emf that alternates from maximum in one direction to maximum in the other direction.

In the graph below we see the voltage and current start at zero, increase to a maximum in the positive direction, then fall to zero, reach a maximum in the negative direction and return to zero. This is one cycle.

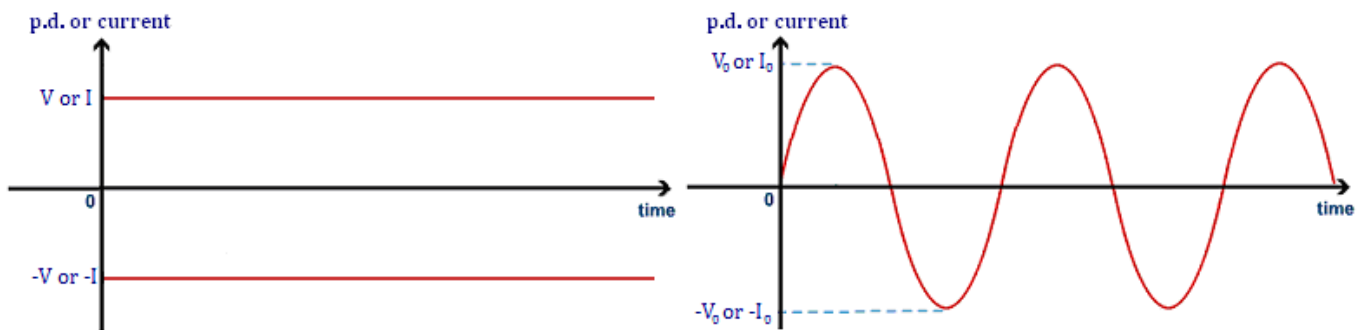

### Alternating Current Definitions

#### Peak Value

The peak value of either the current or the potential difference is the maximum in either direction. It can be measured from the wave as the amplitude, the distance from 0 to the top (or bottom) of the wave. We denote peak current with  $I_0$  and peak p.d. with  $V_0$ .

#### Peak-to-Peak Value

The peak-to-peak value of either the current or potential difference is the range of the values. This is literally the distance from the peak above the zero line to the peak below the line.

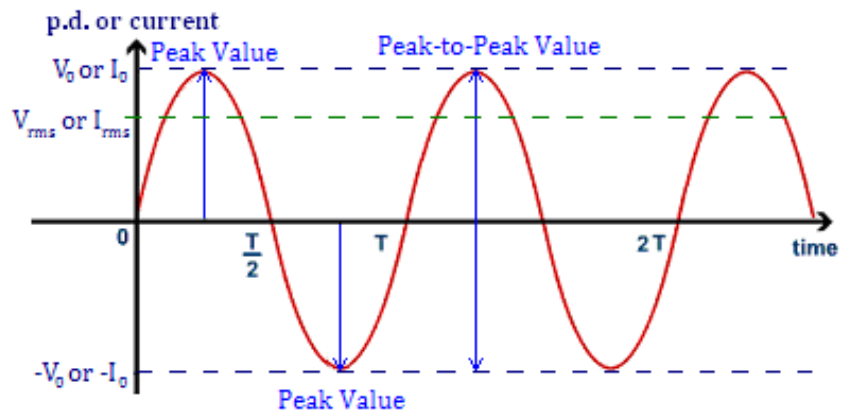

#### Time Period

In an a.c. current or p.d. this is the time taken for one complete cycle (or wave).

#### Frequency

As with its use at GCSE, frequency is a measure of how many complete cycles that occur per second.

**Frequency is measured in Hertz, Hz.**

#### Root Mean Squared, r.m.s.

Since the current and p.d. is constantly changing it is impossible to assign them a fixed value over a period of time, the average would be zero. The r.m.s. current produces the same heating effect in a resistor as the equivalent d.c. for example 12V dc = 12Vrms ac

$$I_{rms} = \frac{I_0}{\sqrt{2}}$$

which can be rearranged to give

$$I_0 = I_{rms} \sqrt{2}$$

$$V_{rms} = \frac{V_0}{\sqrt{2}}$$

which can also be rearranged to give

$$V_0 = V_{rms} \sqrt{2}$$

Unit 4	Mr Shepherd <b>The Oscilloscope</b>	
Learning Outcomes	To know what are the main controls of the oscilloscope	
	To be able to determine the voltage and current using an oscilloscope	
	To be able to determine the time period and frequency using an oscilloscope	

### The Oscilloscope

An oscilloscope can be used to show the sizes of voltages and currents in both d.c. and a.c. circuits. This is what a typical oscilloscope looks like. A trace would be seen on the grid display.

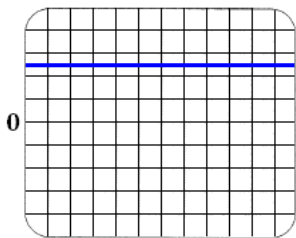
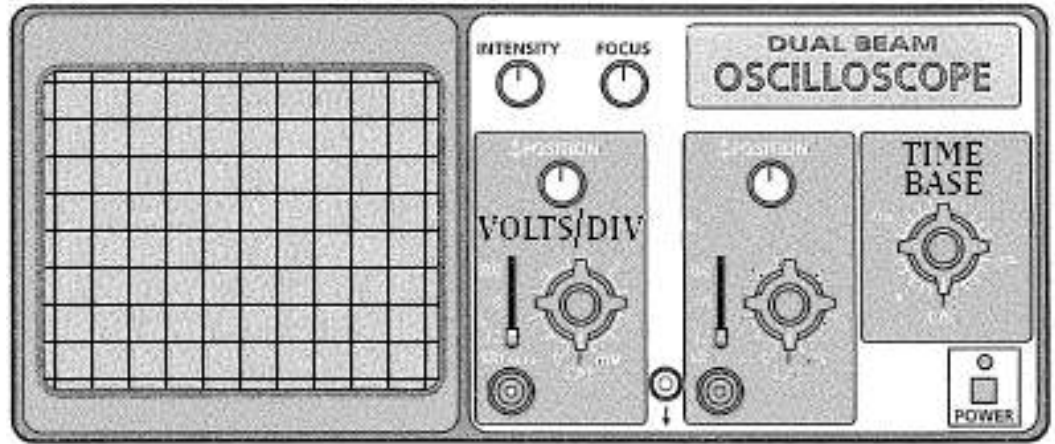

#### D.C. Traces *(Also seen in GCSE Physics 2)*

If we connected a battery or cell to an oscilloscope, we would see a trace similar to the one shown here. The current of a d.c. supply is constant, this means the voltage is constant.

We see a straight line.

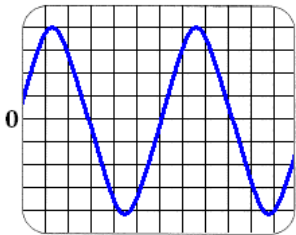

#### A.C. Traces *(Also seen in GCSE Physics 2)*

If we connect anything that draws power from the Mains to an oscilloscope we will see a similar trace to the one shown here. The current is constantly changing from maximum flow in one direction to maximum flow in the other direction; this means the voltage is doing the same.

We see a wave.

### Controls

There are two main controls that we use are the volts/div and time base dials:

The volts/div (volts per division) dial allows you to change how much each vertical square is worth.

The time base dial allows you to change how much each horizontal square is worth.

### Voltage

We can measure the voltage of a d.c. supply by counting the number of vertical squares from the origin to the line and then multiplying it by the volts/div. In the trace the line is 2.5 squares above 0, if each square is worth 5 volts the voltage is (2.5 x 5) 12.5 volts.

We can measure the peak voltage of an a.c. supply by counting how many vertical squares from the centre of the wave to the top and then multiplying it by the volts/div (how much voltage each square is worth). In the trace the peak voltage is 4 squares high, if each square is worth 5 volts the voltage is (4 x 5) 20 volts.

### Time and Frequency

We can measure the time for one period (wave) by counting how many horizontal squares one wavelength is and then multiplying it by the time base (how much time each square is worth).

In the trace above one wave is 6 squares long, if each square is worth 0.02 seconds the time for one wave is 0.12 seconds.

We can calculate the frequency (how many waves or many times this happens per second) using the equation:

$$f = \frac{1}{T} \quad \text{and} \quad T = \frac{1}{f}$$

If the time period is 0.12 seconds, the frequency is 8.33Hz

**Frequency is measured in Hertz, Hz**

Unit 3	Mr Shepherd <b>Motion Graphs</b>	
Learning Outcomes	To be able to interpret displacement-time and velocity-time graphs	
	To be able to represent motion with displacement-time and velocity-time graphs	
	To know the significance of the gradient of a line and the area under it	

Before we look at the two types of graphs we use to represent motion, we must make sure we know how to calculate the gradient of a line and the area under it.

### Gradient

We calculate the gradient by choosing two points on the line and calculating the change in the y axis (up/down) and the change in the x axis (across).

$$\text{gradient} = \frac{\Delta y}{\Delta x}$$

### Area Under Graph

At this level we will not be asked to calculate the area under curves, only straight lines.

We do this by breaking the area into rectangles (base x height) and triangles ( $\frac{1}{2}$  base x height).

### Displacement-Time Graphs (Also seen in GCSE Physics 2)

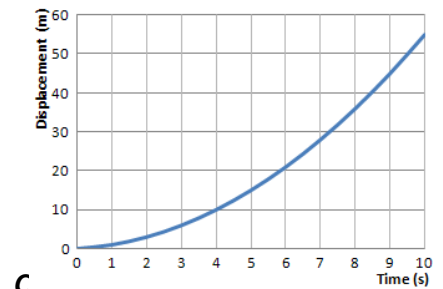
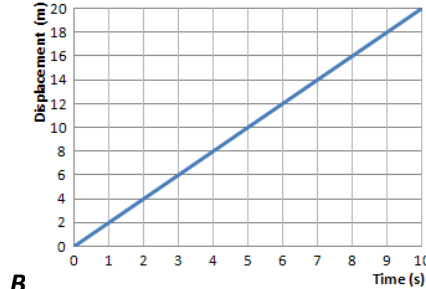
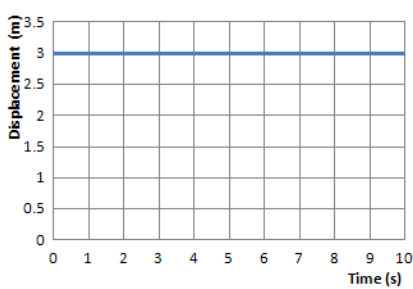

Graph A shows that the displacement stays at 3m, it is stationary.

Graph B shows that the displacement increases by the same amount each second, it is travelling with constant velocity.

Graph C shows that the displacement covered each second increases each second, it is accelerating.

Since  $\text{gradient} = \frac{\Delta y}{\Delta x}$  and  $y = \text{displacement}$  and  $x = \text{time} \rightarrow \text{gradient} = \frac{\Delta s}{\Delta t} \rightarrow \boxed{\text{gradient} = \text{velocity}}$

### Velocity-Time Graphs (Also seen in GCSE Physics 2)

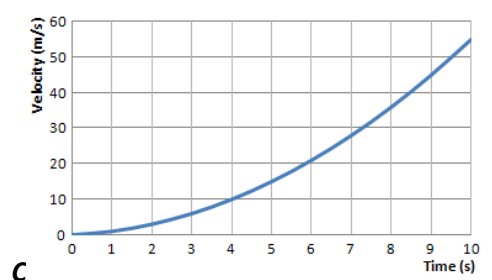
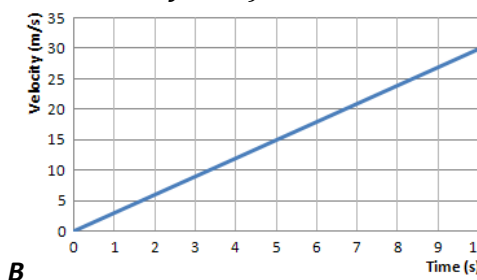
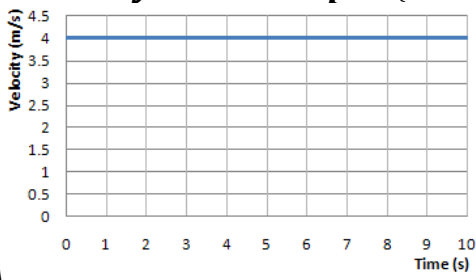

Graph A shows that the velocity stays at 4m/s, it is moving with constant velocity.

Graph B shows that the velocity increases by the same amount each second, it is accelerating by the same amount each second (uniform acceleration).

Graph C shows that the velocity increases by a larger amount each second, the acceleration is increasing (non-uniform acceleration).

Since  $\text{gradient} = \frac{\Delta y}{\Delta x}$  and  $y = \text{velocity}$  and  $x = \text{time} \rightarrow \text{gradient} = \frac{\Delta v}{\Delta t} \rightarrow \boxed{\text{gradient} = \text{acceleration}}$

area = base x height  $\rightarrow$  area = time x velocity  $\rightarrow \boxed{\text{area} = \text{displacement}}$

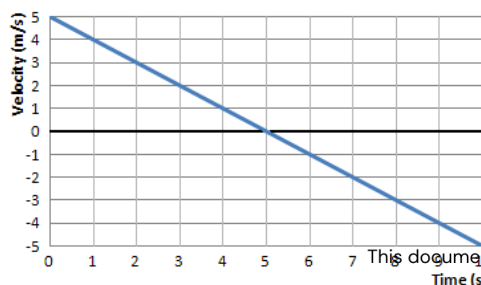

This graph shows the velocity decreasing in one direction and increasing in the opposite direction.

If we decide that  $\leftarrow$  is negative and  $\rightarrow$  is positive then the graph tells us:

The object initially travels at 5 m/s  $\rightarrow$

It slows down by 1m/s every second

After 5 seconds the object has stopped

It then begins to move

It gains 1m/s every second until it is travelling at 5m/s  $\leftarrow$

Unit 3	Mr Shepherd	
	<h1>Velocity and Acceleration</h1>	
Learning Outcomes	To be able to calculate distance and displacement and explain what they are	
	To be able to calculate speed and velocity and explain what they are	
	To be able to calculate acceleration and explain uniform and non-uniform cases	

### Distance *(Also seen in Physics 2)*

Distance is a scalar quantity. It is a measure of the total length you have moved.

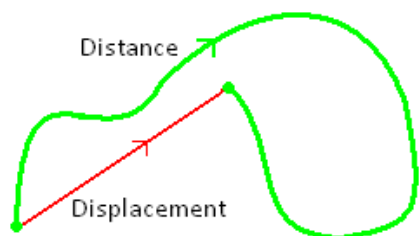

If you complete a lap of an athletics track: distance travelled = 400m  
displacement = 0

### Displacement *(Also seen in Physics 2)*

Displacement is a vector quantity. It is a measure of how far you are from the starting position.

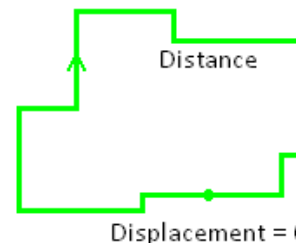
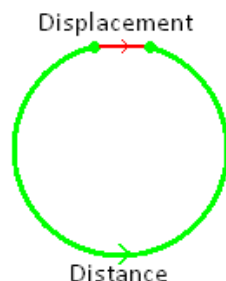

**Distance and Displacement are measured in metres, m**

### Speed *(Also seen in Physics 2)*

Speed is a measure of how the distance changes with time. Since it is dependent on speed it too is a scalar.

$$\text{speed} = \frac{\Delta d}{\Delta t}$$

### Velocity *(Also seen in Physics 2)*

Velocity is measure of how the displacement changes with time. Since it depends on displacement it is a vector too.

$$v = \frac{\Delta s}{\Delta t}$$

**Speed and Velocity are is measured in metres per second, m/s  
Time is measured in seconds, s**

### Acceleration *(Also seen in Physics 2)*

Acceleration is the rate at which the velocity changes. Since velocity is a vector quantity, so is acceleration. With all vectors, the direction is important. In questions we decide which direction is positive (e.g.  $\rightarrow$  +ve)

If a moving object has a positive velocity:

- \* a positive acceleration means an increase in the velocity
- \* a negative acceleration means a decrease in the velocity (it begins the 'speed up' in the other direction)

If a moving object has a negative velocity:

- \* a positive acceleration means an increase in the velocity (it begins the 'speed up' in the other direction)
- \* a negative acceleration means a increase in the velocity

If an object accelerates from a velocity of  $u$  to a velocity of  $v$ , and it takes  $t$  seconds to do it then we can write

the equations as  $a = \frac{(v-u)}{t}$  it may also look like this  $a = \frac{\Delta v}{\Delta t}$  where  $\Delta$  means the 'change in'

**Acceleration is measured in metres per second squared, m/s<sup>2</sup>**

#### Uniform Acceleration

In this situation the acceleration is constant – the velocity changes by the same amount each unit of time. For example: If acceleration is 2m/s<sup>2</sup>, this means the velocity increases by 2m/s every second.

Time (s)	0	1	2	3	4	5	6	7
Velocity (m/s)	0	2	4	6	8	10	12	14
Acceleration (m/s <sup>2</sup> )		2	2	2	2	2	2	2

#### Non-Uniform Acceleration

In this situation the acceleration is changing – the velocity changes by a different amount each unit of time. For example:

Time (s)	0	1	2	3	4	5	6	7
Velocity (m/s)	0	2	6	10	18	28	30	44
Acceleration (m/s <sup>2</sup> )		2	4	6	8	10	12	14

Unit 3	Mr Shepherd	
	<h1>Equations of Motion</h1>	
Learning Outcomes	To be able to use the four equations of motion	
	To know the correct units to be used	
	To be able to find the missing variable: s, u, v, a or t	

## Defining Symbols

Before we look at the equations we need to assign letters to represent each variable

Displacement	= $s$	m	metres
Initial Velocity	= $u$	m/s	metres per second
Final Velocity	= $v$	m/s	metres per second
Acceleration	= $a$	m/s <sup>2</sup>	metres per second per second
Time	= $t$	s	seconds

## Equations of Motion

### Equation 1

If we start with the equation for acceleration  $a = \frac{(v-u)}{t}$  we can rearrange this to give us an equation 1

$$at = (v-u) \rightarrow at + u = v$$

$$\boxed{v = u + at}$$

### Equation 2

We start with the definition of velocity and rearrange for displacement  
velocity = displacement / time  $\rightarrow$  displacement = velocity x time

In situations like the graph to the right the velocity is constantly changing, we need to use the average velocity.

$$\text{displacement} = \text{average velocity} \times \text{time}$$

The average velocity is given by: average velocity =  $\frac{(u+v)}{2}$

We now substitute this into the equation above for displacement

$$\text{displacement} = \frac{(u+v)}{2} \times \text{time} \rightarrow s = \frac{(u+v)}{2}t$$

$$\boxed{s = \frac{1}{2}(u+v)t}$$

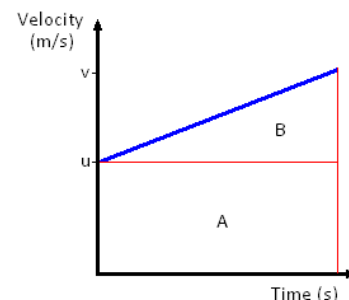

### Equation 3

With Equations 1 and 2 we can derive an equation which eliminated  $v$ . To do this we simply substitute  $v = u + at$  into  $s = \frac{1}{2}(u+v)t$

$$s = \frac{1}{2}(u + (u + at))t \rightarrow s = \frac{1}{2}(2u + at)t \rightarrow s = \frac{1}{2}(2ut + at^2)$$

$$\boxed{s = ut + \frac{1}{2}at^2}$$

This can also be found if we remember that the area under a velocity-time graph represents the distance travelled/displacement. The area under the line equals the area of rectangle A + the area of triangle B.

Area = Displacement =  $s = ut + \frac{1}{2}(v-u)t$  since  $a = \frac{(v-u)}{t}$  then  $at = (v-u)$  so the equation becomes

$$s = ut + \frac{1}{2}(at)t \text{ which then becomes equation 3}$$

### Equation 4

If we rearrange equation 1 into  $t = \frac{(v-u)}{a}$  which we will then substitute into equation 2:

$$s = \frac{1}{2}(u+v)t \rightarrow s = \frac{1}{2}(u+v) \frac{(v-u)}{a} \rightarrow as = \frac{1}{2}(u+v)(v-u) \rightarrow$$

$$2as = (v^2 + uv - uv - u^2) \rightarrow 2as = v^2 - u^2$$

$$\boxed{v^2 = u^2 + 2as}$$

Any question can be solved as long as three of the variables are given in the question.

Write down all the variables you have and the one you are asked to find, then see which equation you can use.

These equations can only be used for motion with UNIFORM ACCELERATION.



Unit 3	Mr Shepherd	
	<h1>Terminal Velocity and Projectiles</h1>	
Learning Outcomes	To know what terminal velocity is and how it occurs	
	To be know how vertical and horizontal motion are connected	
	To be able to calculate the horizontal and vertical distance travelled by a projectile	

### Acceleration Due To Gravity *(Also seen in GCSE Physics 2)*

An object that falls freely will accelerate towards the Earth because of the force of gravity acting on it. The size of this acceleration does not depend mass, so a feather and a bowling ball accelerate at the same rate. On the Moon they hit the ground at the same time, on Earth the resistance of the air slows the feather more than the bowling ball.

The size of the gravitational field affects the magnitude of the acceleration. Near the surface of the Earth the gravitational field strength is 9.81 N/kg. This is also the acceleration a free falling object would have on Earth. In the equations of motion  $a = g = 9.81 \text{ m/s}^2$ .

**Mass** is a property that tells us how much matter it is made of.

**Mass is measured in kilograms, kg**

**Weight** is a force caused by gravity acting on a mass:

weight = mass x gravitational field strength

$$w = mg$$

**Weight is measured in Newtons, N**

### Terminal Velocity *(Also seen in GCSE Physics 2)*

If an object is pushed out of a plane it will accelerate towards the ground because of its weight (due to the Earth's gravity). Its velocity will increase as it falls but as it does, so does the drag forces acting on the object (air resistance). Eventually the air resistance will balance the weight of the object. This means there will be no overall force which means there will be no acceleration. The object stops accelerating and has reached its terminal velocity.

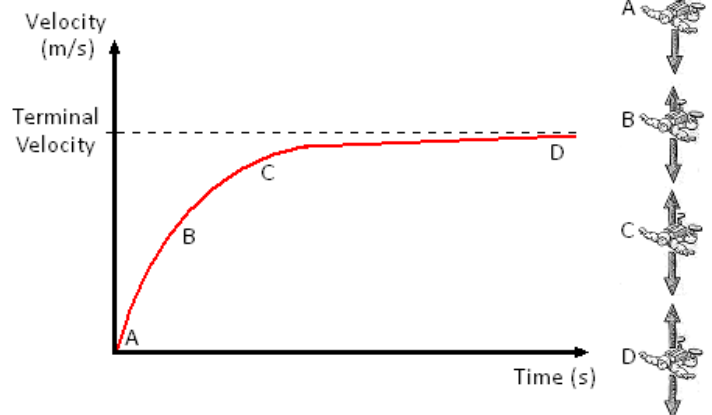

### Projectiles

An object kicked or thrown into the air will follow a parabolic path like that shown to the right.

If the object had an initial velocity of  $u$ , this can be resolved into its horizontal and vertical velocity (as we have seen in Lesson 2)

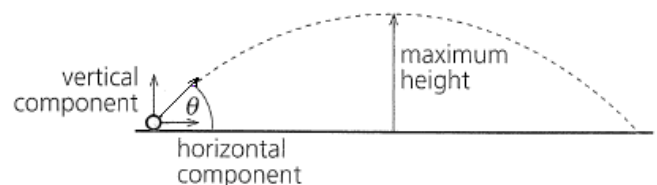

The horizontal velocity will be  $u \cos \theta$  and the vertical velocity will be  $u \sin \theta$ . With these we can solve projectile questions using the equations of motion we already know.

### Horizontal and Vertical Motion

The diagram shows two balls that are released at the same time, one is released and the other has a horizontal velocity. We see that the ball shot from the cannon falls at the same rate at the ball that was released. This is because the horizontal and vertical components of motion are independent of each other.

**Horizontal:** The horizontal velocity is constant; we see that the fired ball covers the same horizontal (across) distance with each second.

**Vertical:** The vertical velocity accelerates at a rate of  $g$  ( $9.81 \text{ m/s}^2$ ). We can see this more clearly in the released ball; it covers more distance each second.

The horizontal velocity has no affect on the vertical velocity. If a ball were fired from the cannon at a high horizontal velocity it would travel further but still take the same time to reach the ground.

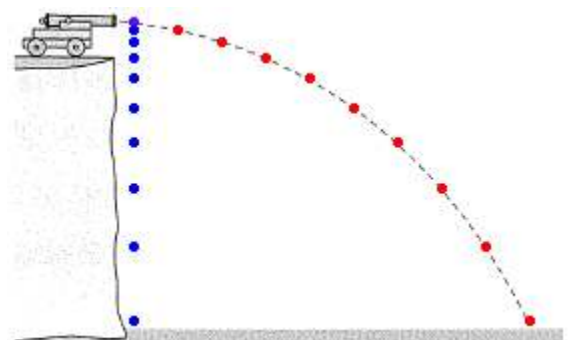

Unit 3	Mr Shepherd	
	<h1>Moments</h1>	
Learning Outcomes	To be able to calculate the moment of a single and a pair of forces	
	To be able to explain what the centre of mass and gravity are	
	To be able to explain how something balances and becomes stable	

### Moments (Also seen in GCSE Physics 3)

The moment of a force is its turning effect about a fixed point (pivot).

The magnitude of the moment is given by:

moment = force x perpendicular distance from force to the pivot

$$\text{moment} = Fs$$

In this diagram we can see that the force is not acting perpendicularly to the pivot.

We must find the perpendicular or closest distance, this is  $s \cos \theta$ .

The moment in this case is given as:

$$\text{moment} = Fs \cos \theta$$

We could have also used the value of  $s$  but multiplied it by the vertical component of the force. This would give us the same equation.

$$\text{moment} = F \cos \theta \cdot s$$

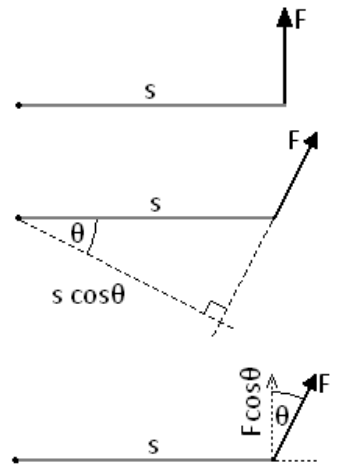

Moments are measured in Newton metres, Nm

### Couples

A couple is a pair of equal forces acting in opposite directions. If a couple acts on an object it rotates in position. The moment of a couple is called the torque.

The torque is calculated as: torque = force x perpendicular distance between forces

$$\text{torque} = Fs$$

In the diagram to the right we need to calculate the perpendicular distance,  $s \cos \theta$ .

So in this case:

$$\text{torque} = Fs \cos \theta$$

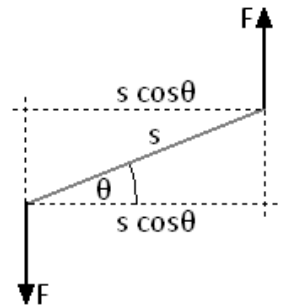

Torque is measured in Newton metres, Nm

### Centre of Mass (Also seen in GCSE Physics 3)

If we look at the ruler to the right, every part of it has a mass. To make tackling questions easier we can assume that all the mass is concentrated in a single point.

### Centre of Gravity

The centre of gravity of an object is the point where all the weight of the object appears to act. It is in the same position as the centre of mass.

We can represent the weight of an object as a downward arrow acting from the centre of mass or gravity. This can also be called the line of action of the weight.

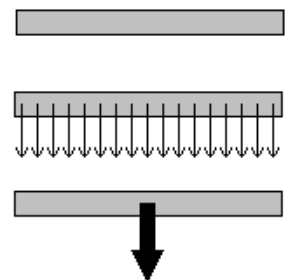

### Balancing (Also seen in GCSE Physics 3)

When an object is balanced:

$$\text{the total moments acting clockwise} = \text{the total moments acting anticlockwise}$$

An object suspended from a point (e.g. a pin) will come to rest with the centre of mass directly below the point of suspension.

If the seesaw to the left is balanced then the clockwise moments must be equal to the anticlockwise moments.

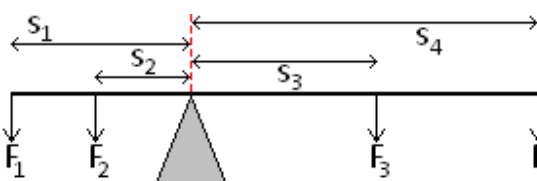

Clockwise moment due to 3 and 4

$$\text{moment} = F_3 s_3 + F_4 s_4$$

Anticlockwise moments due to 1 and 2

$$\text{moment} = F_1 s_1 + F_2 s_2$$

$$\text{So } F_3 s_3 + F_4 s_4 = F_1 s_1 + F_2 s_2$$

### Stability (Also seen in GCSE Physics 3)

The stability of an object can be increased by lowering the centre of mass and by widening the base.

An object will topple over if the line of action of the weight falls outside the base.

Unit 3	Mr Shepherd	
	<h1>Newton's Laws</h1>	
Learning Outcomes	To know and be able to use Newton's 1 <sup>st</sup> law of motion, where appropriate	
	To know and be able to use Newton's 2 <sup>nd</sup> law of motion, where appropriate	
	To know and be able to use Newton's 3 <sup>rd</sup> law of motion, where appropriate	

### **Newton's 1<sup>st</sup> Law**

An object will remain at rest, or continue to move with uniform velocity, unless it is acted upon by an external resultant force.

### **Newton's 2<sup>nd</sup> Law**

The rate of change of an object's linear momentum is directly proportional to the resultant external force. The change in the momentum takes place in the direction of the force.

### **Newton's 3<sup>rd</sup> Law**

When body A exerts a force on body B, body B exerts an equal but opposite force on body A.

**Force is measured in Newtons, N**

### **Say What?**

#### **Newton's 1<sup>st</sup> Law**

If the forward and backward forces cancel out, a stationary object will remain stationary.

If the forward forces are greater than the backwards forces, a stationary object will begin to move forwards.

If the forward and backward forces cancel out, a moving object will continue to move with constant velocity.

If the forward forces are greater than the backward forces, a moving object will speed up.

If the backward forces are greater than the forward forces, a moving object will slow down.

#### **Newton's 2<sup>nd</sup> Law**

The acceleration of an object increases when the force is increased but decreases when the mass is increased:

$$a = \frac{F}{m} \text{ but we rearrange this and use } \boxed{F = ma}$$

#### **Newton's 3<sup>rd</sup> Law**

Forces are created in pairs.

As you sit on the chair your weight pushes down on the chair, the chair also pushes up against you.

As the chair rests on the floor its weight pushes down on the floor, the floor also pushes up against the chair.

The forces have the same size but opposite directions.

### **Riding the Bus**

#### **Newton's 1<sup>st</sup> Law**

You get on a bus and stand up. When the bus is stationary you feel no force, when the bus accelerates you feel a backwards force. You want to stay where you are but the bus forces you to move. When the bus is at a constant speed you feel no forwards or backwards forces. The bus slows down and you feel a forwards force.

You want to keep moving at the same speed but the bus is slowing down so you fall forwards. If the bus turns left you want to keep moving in a straight line so you are forced to the right (in comparison to the bus). If the bus turns right you want to keep moving in a straight line so you are forced left (in comparison to the bus).

#### **Newton's 2<sup>nd</sup> Law**

As more people get on the bus its mass increases, if the driving force of the bus's engine is constant we can see that it takes longer for the bus to gain speed.

#### **Newton's 3<sup>rd</sup> Law**

As you stand on the bus you are pushing down on the floor with a force that is equal to your weight. If this was the only force acting you would begin to move through the floor. The floor is exerting a force of equal magnitude but upwards (in the opposite direction).

### **Taking the Lift**

#### **Newton's 1<sup>st</sup> Law**

When you get in the lift and when it moves at a constant speed you feel no force up or down. When it sets off going up you feel like you are pushed down, you want to stay where you are. When it sets off going down you feel like you are lighter, you feel pulled up.

#### **Newton's 2<sup>nd</sup> Law**

As more people get in the lift its mass increases, if the lifting force is constant we can see that it takes longer for the lift to get moving. Or we can see that with more people the greater the lifting force must be.

#### **Newton's 3<sup>rd</sup> Law**

As you stand in the lift you push down on the floor, the floor pushes back.

Unit 3	Mr Shepherd	
	<h1>Momentum and Collisions</h1>	
Learning Outcomes	To be able to calculate momentum and know the units	
	To be able to explain the difference between elastic and inelastic collisions	
	To be able to find the velocity of an object after a collision or explosion	

### Momentum (Also seen in GCSE Physics 2)

The momentum of an object is given by the equation:

$$\text{momentum} = \text{mass} \times \text{velocity}$$

$$p = mv$$

Since it depends on the velocity and not speed, momentum is a vector quantity. If we assign a direction to be positive for example if  $\rightarrow$  was positive, an object with negative velocity would be moving  $\leftarrow$ . It would also have a negative momentum.

**Momentum is measured in kilogram metres per second, kg m/s or kg m s<sup>-1</sup>**

### Conservation (Also seen in GCSE Physics 2)

In an isolated system (if no external forces are acting) the linear momentum is conserved.

We can say that:

$$\text{the total momentum before} = \text{the total momentum after}$$

The total momentum before and after what? A collision or an explosion.

### Collisions (Also seen in GCSE Physics 2)

There are two types of collisions; in both cases the momentum is conserved.

#### Elastic – kinetic energy is conserved, no energy is transferred to the surroundings

If a ball is dropped, hits the floor and bounces back to the same height it would be an elastic collision with the floor. The kinetic energy before the collision is the same as the kinetic energy after the collision.

#### Inelastic – kinetic energy is not conserved, energy is transferred to the surroundings

If a ball is dropped, hits the floor and bounces back to a lower height than released it would be an inelastic collision. The kinetic energy before the collision would be greater than the kinetic energy after the collision.

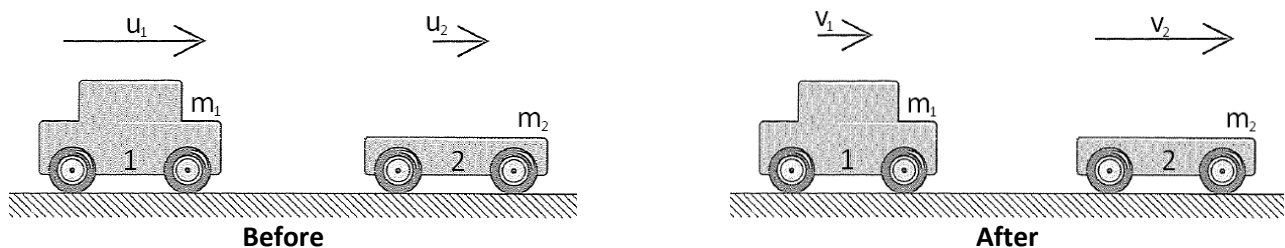

In the situation above, car 1 and car 2 travel to the right with initial velocities  $u_1$  and  $u_2$  respectively. Car 1 catches up to car 2 and they collide. After the collision the cars continue to move to the right but car 1 now travels at velocity  $v_1$  and car 2 travels a velocity  $v_2$ . [ $\rightarrow$  is positive]

Since momentum is conserved the total momentum before the crash = the total momentum after the crash.

The total momentum before is the momentum of A + the momentum of B

The total momentum after is the new momentum of A + the new momentum of B

We can represent this with the equation:

$$m_1u_1 + m_2u_2 = m_1v_1 + m_2v_2$$

### Explosions (Also seen in GCSE Physics 2)

We look at explosions in the same way as we look at collisions, the total momentum before is equal to the total momentum after. In explosions the total momentum before is zero. [ $\rightarrow$  is positive]

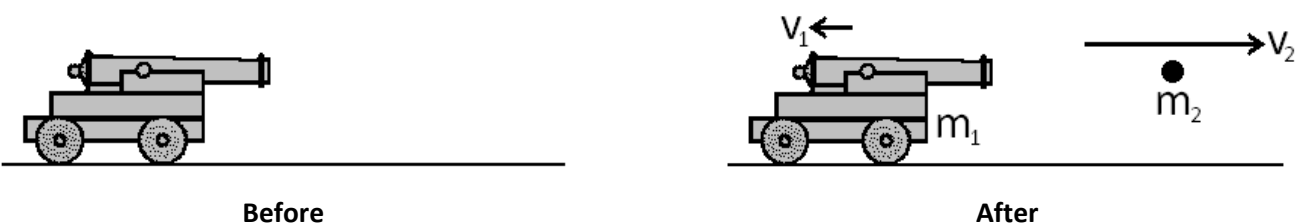

If we look at the example above we can see that the whole system is not moving, so the momentum before is zero. After the explosion the shell travels right with velocity  $v_2$  and the cannon recoils with a velocity  $v_1$ .

The momentum of the system is given as:

$$m_1u_1 + m_2u_2 = m_1v_1 + m_2v_2$$

So the equation for this diagram would be:

$$0 = m_1v_1 + m_2v_2$$

But remember,  $v_1$  is negative so:

$$0 = m_1v_1 + m_2v_2 \Rightarrow m_1v_1 = -m_2v_2$$

Unit 3	Mr Shepherd	
	<h1>Force and Impulse</h1>	
Learning Outcomes	To be able to calculate force from change in momentum	
	To be able to explain and calculate impulse	
	To know the significance of the area under a force-time graph	

### Force (Also seen in GCSE Physics 2)

If we start at  $F = ma$  we can derive an equation that links force and momentum.

$F = ma$  we can replace  $a$  in this equation with  $a = \frac{(v-u)}{t}$  from Unit 2

$F = m \frac{(v-u)}{t}$  multiplying out makes the equation

$$F = \frac{mv - mu}{t} \quad \text{or} \quad \boxed{F = \frac{\Delta(mv)}{\Delta t}} \quad \text{where } \Delta \text{ means 'the change in'}$$

This states that the force is a measure of change of momentum with respect to time. This is Newton's Second Law of Motion:

*The rate of change of an object's linear momentum is directly proportional to the resultant external force.  
The change in the momentum takes place in the direction of the force.*

If we have a trolley and we increase its velocity from rest to 3m/s in 10 seconds, we know that it takes a bigger force to do the same with a trolley that's full of shopping. Ever tried turning a trolley around a corner when empty and then when full?

**Force is measured in Newtons, N**

### Car Safety (Also seen in GCSE Physics 2)

Many of the safety features of a car rely on the above equation. Airbags, seatbelts and the crumple zone increase the time taken for the car and the people inside to stop moving. Increasing the time taken to change the momentum to zero reduces the force experienced.

### Catching

**An Egg:** If we held our hand out and didn't move it the egg would smash. The change in momentum happens in a short time, making the force large. If we cup the egg and move our hands down as we catch it we make it take longer to come to a complete stop. Increasing the time taken decreases the force and the egg remains intact.  
**Cricket Ball:** If we didn't move our hands it would hurt when the ball stopped in our hands. If we make it take longer to stop we reduce the force on our hands from the ball.

### Impulse

$$F = \frac{mv - mu}{t} \quad \text{multiply both sides by } t \quad \rightarrow \quad Ft = mv - mu$$

$$F = \frac{\Delta(mv)}{\Delta t} \quad \text{multiply both sides by } \Delta t \quad \rightarrow \quad \boxed{F\Delta t = \Delta(mv)}$$

We now have an equation for impulse. Impulse is the product of the force and the time it is applied for. An impulse causes a change in momentum.

**Impulse is measured in Newton seconds, Ns**

Since  $F\Delta t = \Delta(mv)$ , the same impulse (same force applied for the same amount of time) can be applied to a small mass to cause a large velocity or to a large mass to cause a small velocity

$$Ft = \mathbf{M}_v = m \mathbf{V}$$

### Force-Time Graphs

The impulse can be calculated from a force-time graph, it is the same as the area under the graph.

The area of the first graph is given by:

height x length = Force x time = Impulse

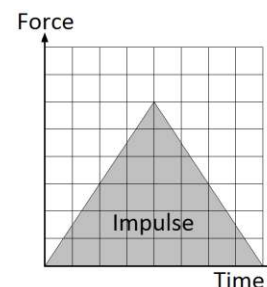
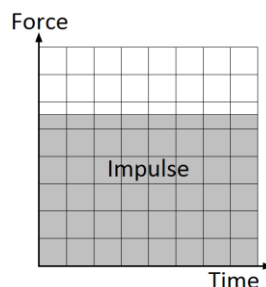

Unit 3	Mr Shepherd	
	<h1>Work, Energy and Power</h1>	
Learning Outcomes	To be able to calculate work done (including situations involving an inclined plane)	
	To be able to calculate the power of a device	
	To be able to calculate efficiency and percentage efficiency	

### Energy (Also seen in GCSE Physics 1)

We already know that it appears in a number of different forms and may be transformed from one form to another. But what is energy? **Energy is the ability to do work.**

We can say that the work done is equal to the energy transferred

$$\text{Work done} = \text{energy transferred} \quad \boxed{W = E}$$

### Work Done (Also seen in GCSE Physics 2)

In Physics we say that work is done when a force moves through a distance and established the equation

$$\text{Work Done} = \text{Force} \times \text{Distance moved in the direction of the force} \quad \boxed{W = Fs}$$

**Work Done is measured in Joules, J**

**Force is measured in Newtons, N**

**Distance is measured in metres, m**

The distance moved is not always in the direction of the force. In the diagram we can see that the block moves in a direction that is  $\theta$  away from the 'line of action' of the force. To calculate the work done we must calculate the distance we move in the direction of the force or the size of the force in the direction of the distance moved. Both of these are calculated by resolving into horizontal and vertical components.

Work Done = Force x Distance moved in the direction of the force

Work Done = Size of Force in the direction of movement x Distance moved

$$\boxed{\text{Work Done} = Fs \cos \theta}$$

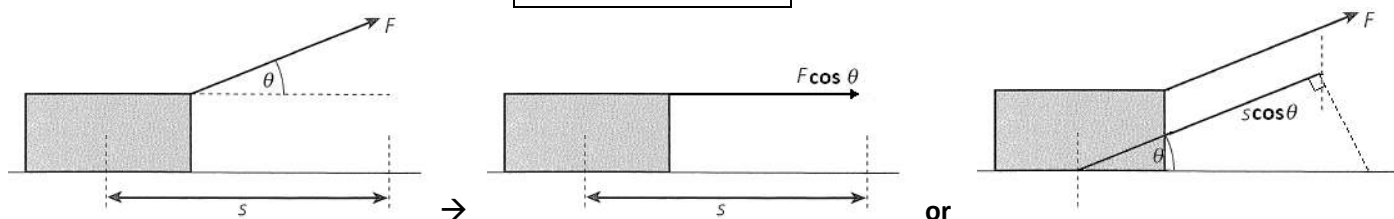

### Power (Also seen in GCSE Physics 1 and AS Unit 1)

Power is a measure of how quickly something can transfer energy. Power is linked to energy by the equation:

$$\boxed{\text{Power} = \frac{\text{Energy Transferred}}{\text{time taken}}} \quad \boxed{P = \frac{\Delta E}{\Delta t}}$$

**Power is measured in Watts, W**

**Energy is measured in Joules, J**

**Time is measured in seconds, s**

But Work Done = Energy Transferred so we can say that power is a measure of how quickly work can be done.

$$\boxed{\text{Power} = \frac{\text{Work Done}}{\text{time taken}}} \quad \boxed{P = \frac{\Delta W}{\Delta t}}$$

Now that we can calculate Work Done we can derive another equation for calculating power:

We can substitute  $W = Fs$  into  $P = \frac{W}{t}$  to become  $P = \frac{Fs}{t}$  this can be separated into  $P = F \frac{s}{t}$ .

$$\frac{s}{t} = v \text{ so we can write} \quad \boxed{P = Fv}$$

**Velocity is measured in metres per second, m/s or ms<sup>-1</sup>**

### Efficiency (Also seen in GCSE Physics 1)

We already know that the efficiency of a device is a measure of how much of the energy we put in is wasted.

$$\text{Efficiency} = \frac{\text{useful energy transferred by the device}}{\text{total energy supplied to the device}} \quad \text{this will give us a number less than 1}$$

Useful energy means the energy transferred for a purpose, the energy transferred into the desired form.

Since power is calculated from energy we can express efficiency as:

$$\text{Efficiency} = \frac{\text{useful output power of the device}}{\text{input power to the device}} \quad \text{again this will give us a number less than 1}$$

To calculate the efficiency as a percentage use the following:

$$\text{percentage efficiency} = \text{efficiency} \times 100\%$$

Unit 3	Mr Shepherd	
	<h1>Conservation of Energy</h1>	
Learning Outcomes	To be able to calculate gravitational potential energy	
	To be able to calculate kinetic energy	
	To be able to solve problems involving the conversion of energy	

### **Energy Transformations** (Also seen in GCSE Physics 1)

We already know that energy cannot be created or destroyed, only transformed from one type to another and transferred from one thing to another. Eg a speaker transforms electrical energy to sound energy with the energy itself is being transferred to the surroundings.

An isolated (or closed) system means an energy transformation is occurring where none of the energy is lost to the surroundings. In reality all transformations/transfers are not isolated, and all of them waste energy to the surroundings.

### **Kinetic Energy** (Also seen in GCSE Physics 2)

Kinetic energy is the energy a moving object has. Let us consider a car that accelerates from being stationary ( $u=0$ ) to travelling at a velocity  $v$  when a force,  $F$ , is applied.

The time it takes to reach this velocity is give by  $v = u + at \rightarrow v = at \rightarrow t = \frac{v}{a}$

The distance moved in this time is given by  $s = \frac{1}{2}(u + v)t \rightarrow s = \frac{1}{2}(v)t \rightarrow s = \frac{1}{2}(v)\frac{v}{a} \rightarrow s = \frac{1}{2}\frac{v^2}{a}$

Energy transferred = Work Done, Work Done = Force x distance moved and Force = mass x acceleration

$$E = W \rightarrow E = Fs \rightarrow E = mas \rightarrow E = ma \frac{1}{2} \frac{v^2}{a}$$

$$\boxed{E_K = \frac{1}{2}mv^2}$$

**Velocity is measured in metres per second, m/s**

**Mass is measured in kilograms, kg**

**Kinetic Energy is measured in Joules, J**

### **Gravitational Potential Energy**

This type of potential (stored) energy is due to the position of an object. If an object of mass  $m$  is lifted at a constant speed by a height of  $h$  we can say that the acceleration is zero. Since  $F=ma$  we can also say that the overall force is zero, this means that the lifting force is equal to the weight of the object  $\rightarrow F=mg$

We can now calculate the work done in lifting the object through a height,  $h$ .

$$WD = Fs \rightarrow WD = (mg)h \rightarrow WD = mgh$$

Since work done = energy transferred

$$\boxed{\Delta E_p = mg\Delta h}$$

**Height is a measure of distance which is measured in metres, m**

**Gravitational Potential Energy is measured in Joules, J**

### **Work Done against....**

In many situations gravitational potential energy is converted into kinetic energy, or vice versa. Some everyday examples of this are:

**Swings and pendulums** If we pull a pendulum back we give it GPE, when it is released it falls, losing its GPE but speeding up and gaining KE. When it passes the lowest point of the swing it begins to rise (gaining GPE) and slow down (losing KE).

**Bouncing or throwing a ball** Holding a ball in the air gives it GPE, when we release this it transforms this into KE. As it rises it loses KE and gains GPE.

**Slides and ramps** A ball at the top of a slide will have GPE. When it reaches the bottom of the slide it has lost all its GPE, but gained KE.

In each of these cases it appears as though we have lost energy. The pendulum doesn't swing back to its original height and the ball never bounces to the height it was released from. This is because work is being done against resistive forces.

The swing has to overcome air resistance whilst moving and the friction from the top support.

The ball transforms some energy into sound and overcoming the air resistance.

Travelling down a slide transforms energy into heat due to friction and air resistance

**The total energy before a transformation = The total energy after a transformation**

Unit 3	Mr Shepherd <b>Hooke's Law</b>	
Learning Outcomes	To be able to state Hooke's Law and explain what the spring constant is	
	To be able to describe how springs behave in series and parallel	
	To be able to derive the energy stored in a stretched material	

### Hooke's Law

If we take a metal wire or a spring and hang it from the ceiling it will have a natural, unstretched length of  $l$  metres. If we then attach masses to the bottom of the wire it will begin to increase in length (stretch). The amount of length it has increased by we will call the extension and represent by  $e$ .

If the extension increases proportionally to the force applied it follows Hooke's Law:

*The force needed to stretch a spring is directly proportional to the extension of the spring from its natural length*  
So it takes twice as much force to extend a spring twice as far and half the force to extend it half as far.

We can write this in equation form:

$$F \propto e$$

or

$$F = ke$$

Here  $k$  is the constant that shows us how much extension in length we would get for a given force. It is called...

### The Spring Constant

The spring constant gives us an idea of the stiffness (or stretchiness) of the material.

If we rearrange Hooke's Law we get:  $k = \frac{F}{e}$

If we record the length of a spring, add masses to the bottom and measure its extension we can plot a graph of force against extension. The gradient of this graph will be equal to the spring constant.

A small force causes a large extension the spring constant will be *small – very stretchy*

A large force causes a small extension the spring constant will be *large – not stretchy*

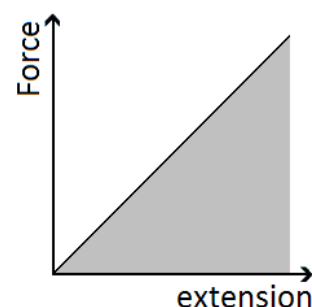

**Spring Constant is measured in Newtons per metre, N/m**

### Springs in Series

The combined spring constant of spring  $A$  and spring  $B$  connected in series is given by:

$$\frac{1}{k_T} = \frac{1}{k_A} + \frac{1}{k_B} \quad \text{If } A \text{ and } B \text{ are identical this becomes:}$$

$$\frac{1}{k_T} = \frac{1}{k} + \frac{1}{k} \quad \rightarrow \quad \frac{1}{k_T} = \frac{2}{k} \quad \rightarrow \quad k_T = \frac{k}{2}$$

Since this gives us a smaller value for the spring constant, applying the same force produces a larger extension. *It is stretchier*

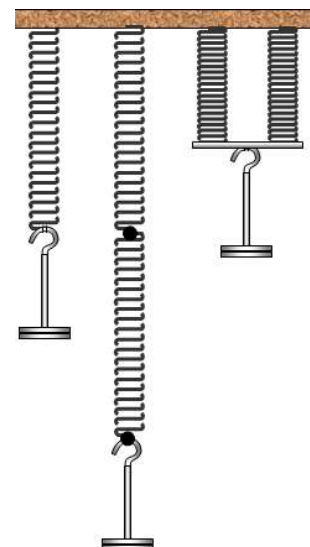

### Springs in Parallel

The combined spring constant of spring  $A$  and spring  $B$  connected in parallel is:

$$k_T = k_A + k_B \quad \text{so if } A \text{ and } B \text{ are identical this becomes:}$$

$$k_T = k + k \quad \rightarrow \quad k_T = 2k$$

Since this gives us a larger value for the spring constant applying the same force produces a smaller extension. *It is less stretchy*

### Energy Stored (Elastic Strain Energy)

We can calculate the energy stored in a stretched material by considering the work done on it.

We defined work done as the force  $\times$  distance moved in the direction of the force or

Work done is equal to the energy transferred, in this case transferred to the material, so:

The distance moved is the extension of the material,  $e$ , making the equation:

$$W = Fs$$

$$E = Fs$$

$$E = Fe$$

$$\frac{(F - 0)}{2}$$

The force is not constant; it increases from zero to a maximum of  $F$ . The average force is given by:

If we bring these terms together we get the equation  $E = \frac{(F - 0)}{2} e$  which simplifies to:

$$E = \frac{1}{2} Fe$$

*This is also equal to the area under the graph of force against extension.*

We can write a second version of this equation by substituting our top equation of  $F = ke$  into the one above.

$$E = \frac{1}{2} Fe \quad \rightarrow \quad E = \frac{1}{2} (ke)e \quad \rightarrow$$

$$E = \frac{1}{2} ke^2$$

This document is available free of charge on





Unit 3	Mr Shepherd	
	<h1>Stress and Strain</h1>	
Learning Outcomes	To know what stress is, be able to explain it, calculate it and state its units	
	To know what strain is, be able to explain it, calculate it and state its units	
	To be able to calculate the elastic strain energy per unit volume	

## Deforming Solids

Forces can be used to change the speed, direction and shape of an object. This section of Physics looks at using forces to change of shape of a solid object, either temporarily or permanently.

If a pair of forces are used to *squash* a material we say that they are *compressive* forces.

If a pair of forces is used to *stretch* a material we say that they are *tensile* forces.

## Tensile Stress, $\sigma$

Tensile stress is defined as the force applied per unit cross-sectional area (which is the same as pressure).

This is represented by the equations:

$$stress = \frac{F}{A} \quad \boxed{\sigma = \frac{F}{A}}$$

The largest tensile stress that can be applied to a material before it breaks is called the ultimate tensile stress (UTS). Nylon has an UTS of 85 MPa whilst Stainless steel has a value of 600 MPa and Kevlar a massive 3100 MPa

**Stress is measured in Newtons per metre squared, N/m<sup>2</sup> or N m<sup>-2</sup>**

**Stress can also be measured in Pascals, Pa**

A tensile stress will cause a tensile strain.

*Stress causes Strain*

## Tensile Strain, $\epsilon$

Tensile strain is a measure of how the extension of a material compares to the original, unstretched length.

This is represented by the equations:

$$strain = \frac{e}{l} \quad \boxed{\epsilon = \frac{e}{l}}$$

Steel wire will undergo a strain of 0.01 before it breaks. This means it will stretch by 1% of its original length then break. Spider silk has a breaking strain of between 0.15 and 0.30, stretching by 30% before breaking

**Strain has no units, it is a ratio of two lengths**

## Stress-Strain Graphs

A stress-strain graph is very useful for comparing different materials.

Here we can see how the strain of two materials, **a** and **b**, changes when a stress is applied.

If we look at the dotted lines we can see that the same amount of stress causes a bigger strain in **b** than in **a**. This means that **b** will increase in length more than **a** (compared to their original lengths).

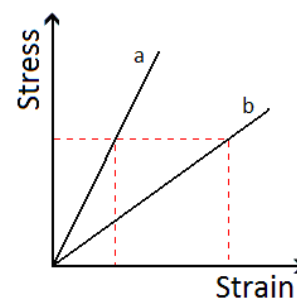

## Elastic Strain Energy

We can build on the idea of energy stored from the previous lesson now that we know what stress and strain are. We can work out the amount of elastic strain energy that is stored *per unit volume* of the material.

It is given by the equation:

$$\boxed{E = \frac{1}{2} stress \times strain}$$

There are two routes we can take to arrive at this result:

### Equations

If we start with the equation for the total energy stored in the material:

$$E = \frac{1}{2} Fe$$

The volume of the material is given by:

$$V = Al$$

Now divide the total energy stored by the volume:  $E = \frac{\frac{1}{2} Fe}{Al}$  which can be written as:

$$E = \frac{1}{2} \frac{F}{A} \frac{e}{l}$$

If we compare the equation to the equations we know for stress and strain we see that:

$$E = \frac{1}{2} stress \times strain$$

### Graphs

The area under a stress-strain graph gives us the elastic strain energy per unit volume (m<sup>3</sup>). The area is given by:

$$A = \frac{1}{2} base \times height \quad \rightarrow \quad A = \frac{1}{2} strain \times stress \quad \text{or} \quad A = \frac{1}{2} stress \times strain \quad \rightarrow \quad E = \frac{1}{2} stress \times strain$$

Unit 3	Mr Shepherd	
	<h1>Bulk Properties of Solids</h1>	
Learning Outcomes	To be able to calculate density and explain what it is	
	To be able to explain what elastic, plastic, yield point, breaking stress, stiff, ductile and brittle are	
	To be able to label these qualities on stress-strain graphs	

### Density, $\rho$

Density is the *mass per unit volume of a material*, a measure of how much mass each cubic metre of volume contains. Density is given by the equation:

$$\rho = \frac{m}{V}$$

Where  $\rho$  is density,  $m$  is mass in kilograms and  $V$  is volume in metres cubed.

**Density is measured in kilograms per metre cubed,  $\text{kg/m}^3$  or  $\text{kg m}^{-3}$**

### Elasticity

Materials extend in length when a stress is applied to them (masses hung from them). A material can be described as elastic if it returns to its original length when the stress is removed. They obey Hooke's Law as extension is proportional to the force applied.

### Limit of Proportionality, $P$

Up to this point the material obeys Hooke's Law; extension is proportional to the force applied.

### Elastic Limit, $E$

The elastic limit is the final point where the material will return to its original length if we remove the stress which is causing the extension (take the masses off). There is no change to the shape or size of the material.

We say that the material acts plastically beyond its elastic limit.

### Yield Point, $Y$

Beyond the elastic limit a point is reached where small increases in stress cause a massive increase in extension (strain). The material will not return to its original length and behaves like a plastic.

### Plasticity

Materials extend in length when a stress is applied to them (masses hung from them). A material can be described as plastic if it does not return to its original length when the stress is removed. There is a permanent change to its shape

### Breaking Stress – Ultimate Tensile Strength, UTS

This is the maximum amount of stress that can be applied to the material without making it break. It is sometimes referred to as the strength of the material.

### Breaking Point, $B$

This is (surprisingly?) the point where the material breaks.

### Stiffness

If different materials were made into wires of equal dimensions, the stiffer materials bend the least.

Stiff materials have low flexibility

### Ductility

A ductile material can be easily and permanently stretched. Copper is a good example, it can easily be drawn out into thin wires. This can be seen in graph **d** below.

### Brittleness

A brittle material will extend obeying Hooke's Law when a stress is applied to it. It will suddenly fracture with no warning sign of plastic deformation. Glass, pottery and chocolate are examples of brittle materials.

### Stress-Strain Graphs

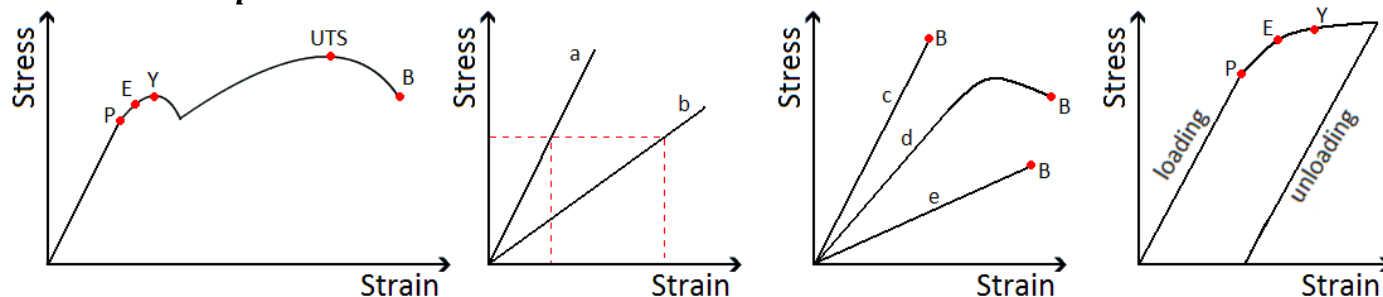

In the first graph we see a material that stretches, shows plastic behaviour and eventually breaks.

In the second graph we can see that material **a** is stiffer than material **b** because the same stress causes a greater strain in **b**.

In the third graph we see materials **c** and **e** are brittle because they break without showing plastic behaviour.

The fourth graph shows how a material can be permanently deformed, the wire does not return to its original length when the stress is removed (the masses have been removed).

Unit 3	Mr Shepherd <h1>The Young Modulus</h1>	
Learning Outcomes	To know what the Young Modulus is, be able to explain it, calculate it and state its units	
	To be able to describe an experiment for finding the Young Modulus	
	To be able to calculate the Young Modulus from a stress-strain graph	

## The Young Modulus, E

The Young Modulus can be thought of as the stiffness constant of a material, a measure of how much strain will result from a stress being applied to the material. It can be used to compare the stiffness of different materials even though their dimensions are not the same.

The Young Modulus only applies up to the limit of proportionality of a material.

$$\text{Young Modulus} = \frac{\text{stress}}{\text{strain}}$$

or in equation terms we have

$$E = \frac{\sigma}{\epsilon}$$

We have equations for stress  $\sigma = \frac{F}{A}$  and strain  $\epsilon = \frac{e}{l}$  which makes the equation look like this:  $E = \frac{\left(\frac{F}{A}\right)}{\left(\frac{e}{l}\right)}$

An easier way of writing this is  $E = \left(\frac{F}{A}\right) \times \left(\frac{l}{e}\right)$  which becomes:

$$E = \frac{Fl}{Ae}$$

**The Young Modulus is measured in Newtons per metre squares, N/m<sup>2</sup> or N m<sup>-2</sup>**

## Stress-Strain Graphs

The Young Modulus of a material can be found from its stress-strain graph.

Since  $\text{gradient} = \frac{\Delta y}{\Delta x}$ , this becomes  $\text{gradient} = \frac{\text{stress}}{\text{strain}}$  for our graph. Our top equation stated that

$\text{Young Modulus} = \frac{\text{stress}}{\text{strain}}$  so we see that the gradient of a stress-strain graph gives us the Young Modulus.

This only applied to the straight line section of the graph, where gradient (and Young Modulus) are constant.

## Measuring the Young Modulus

Here is a simple experimental set up for finding the Young Modulus of a material.

- A piece of wire is held by a G-clamp, sent over a pulley with the smallest mass attached to it. This should keep it straight without extending it.
- Measure the length from the clamp to the pointer. This is the original length (unstretched).
- Use a micrometer to measure the diameter of the wire in several places. Use this to calculate the cross-sectional area of the wire.
- Add a mass to the loaded end of the wire.
- Record the extension by measuring how far the pointer has moved from its start position.
- Repeat for several masses but ensuring the elastic limit is not reached.
- Remove the masses, one at a time taking another set of reading of the extension.
- Calculate stress and strain for each mass.
- Plot a graph of stress against strain and calculate the gradient of the line which gives the Young Modulus.

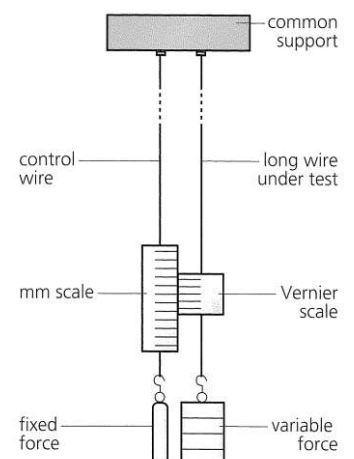
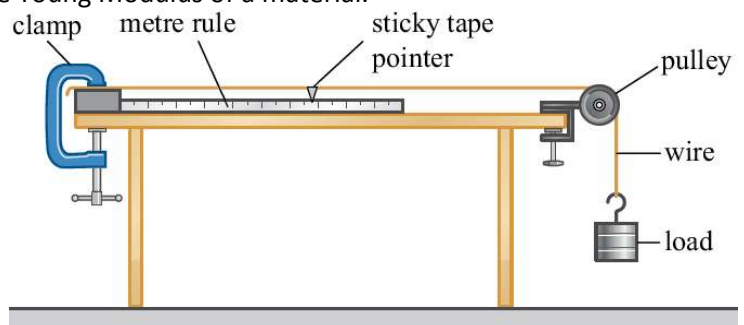

Here is a more precise way of finding the Young Modulus but involves taking the same measurements of extension and force applied.

It is called Searle's apparatus.

Unit 4	Mr Shepherd	
	<h1>Progressive Waves</h1>	
Learning Outcomes	To be know the basic measurements of a wave	
	To be able to calculate the speed of any wave	
	To be know what phase and path difference are and be able to calculate them	

## Waves

All waves are caused by oscillations and all transfer energy without transferring matter. This means that a water wave can transfer energy to you sitting on the shore without the water particles far out to sea moving to the beach.

Here is a diagram of a wave; it is one type of wave called a transverse wave. A wave consists of something (usually particles) oscillating from an equilibrium point. The wave can be described as progressive; this means it is moving outwards from the source.

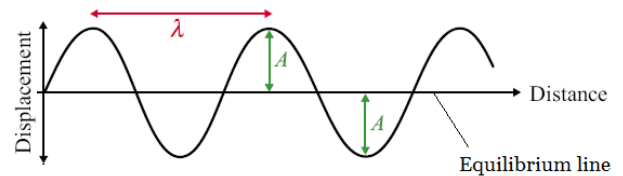

We will now look at some basic measurements and characteristics of waves.

### Amplitude, $A$

The amplitude of a wave is the maximum displacement of the particles from the equilibrium position.

**Amplitude is measured in metres, m**

### Wavelength, $\lambda$

The wavelength of a wave is the length of one whole cycle. It can be measured between two adjacent peaks, troughs or any point on a wave and the same point one wave later.

**Wavelength is measured in metres, m**

### Time Period, $T$

This is simply the time it takes for one complete wave to happen. Like wavelength it can be measured as the time it takes between two adjacent peaks, troughs or to get back to the same point on the wave.

**Time Period is measured in seconds, s**

### Frequency, $f$

Frequency is a measure of how often something happens, in this case how many complete waves occur in every second. It is linked to time period of the wave by the following equations:  $T = \frac{1}{f}$  and  $f = \frac{1}{T}$

**Frequency is measured in Hertz, Hz**

### Wave Speed, $c$

The speed of a wave can be calculated using the following equations:

**Wave Speed is measured in metres per second,  $m\ s^{-1}$**

Here  $c$  represents the speed of the wave,  $f$  the frequency and  $\lambda$  the wavelength.

$$c = f\lambda$$

### Phase Difference

If we look at two particles a wavelength apart (such as C and G) we would see that they are oscillating in time with each other. We say that they are *completely in phase*. Two points half a wavelength apart (such as I and K) we would see that they are always moving in opposite directions. We say that they are *completely out of phase*. The phase difference between two points depends on what fraction of a wavelength lies between them

**Phase Difference is measured in radians, rad**

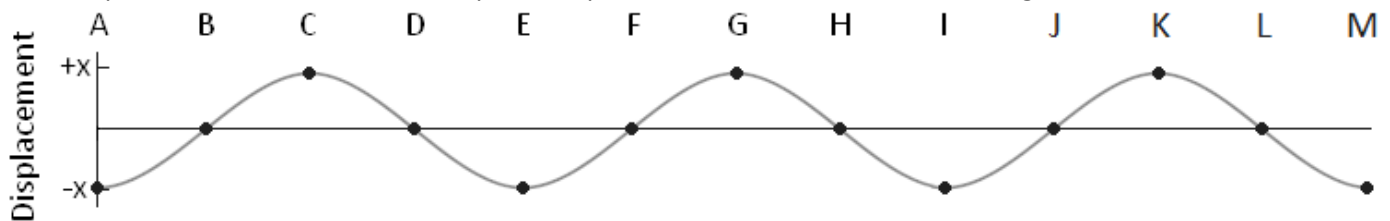

	B	C	D	E	F	G	H	I	J	K	L	M
Phase Difference from A (radians)	$\frac{1}{2}\pi$	$\pi$	$1\frac{1}{2}\pi$	$2\pi$	$2\frac{1}{2}\pi$	$3\pi$	$3\frac{1}{2}\pi$	$4\pi$	$4\frac{1}{2}\pi$	$5\pi$	$5\frac{1}{2}\pi$	$6\pi$
Phase Difference from A (degrees)	90	180	270	360	450	540	630	720	810	900	990	1080

### Path Difference

If two light waves leave a bulb and hit a screen the difference in how far the waves have travelled is called the path difference. Path difference is measured in terms of wavelengths.

**Path Difference is measured in wavelengths,  $\lambda$**

	B	C	D	E	F	G	H	I	J	K	L	M
Path Difference from A	$\frac{1}{4}\lambda$	$\frac{1}{2}\lambda$	$\frac{3}{4}\lambda$	$1\lambda$	$1\frac{1}{4}\lambda$	$1\frac{1}{2}\lambda$	$1\frac{3}{4}\lambda$	$2\lambda$	$2\frac{1}{4}\lambda$	$2\frac{1}{2}\lambda$	$2\frac{3}{4}\lambda$	$3\lambda$

So two waves leaving A with one making it to F and the other to J with a path difference of 1 wavelength ( $1\lambda$ ).

Unit 4	Mr Shepherd		<h1>Longitudinal and Transverse Waves</h1>
Learning Outcomes	To be able explain the differences between longitudinal and transverse waves		
	To know examples of each		
	To be explain what polarisation is and how it proves light is a transverse wave		

## Waves

All waves are caused by oscillations and all transfer energy without transferring matter. This means that a sound wave can transfer energy to your eardrum from a far speaker without the air particles by the speaker moving into your ear. We will now look at the two types of waves and how they are different

### Longitudinal Waves

Here is a longitudinal wave; the oscillations are parallel to the direction of propagation (travel). Where the particles are close together we call a compression and where they are spread we call a rarefaction. The wavelength is the distance from one compression or rarefaction to the next. The amplitude is the maximum distance the particle moves from its equilibrium position to the right or left.

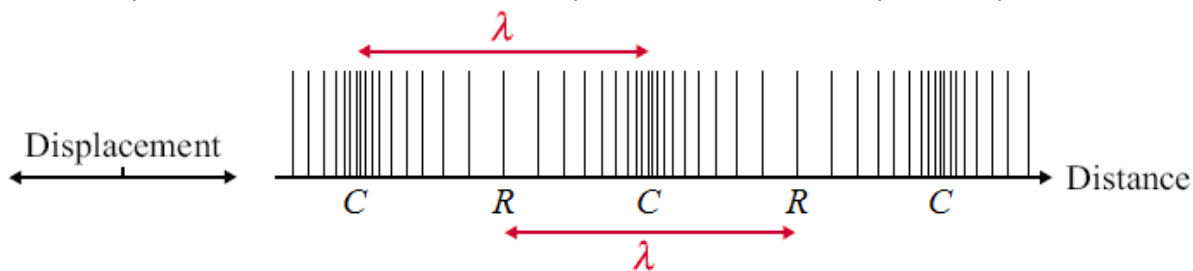

*Example:*  
sound waves

### Transverse Waves

Here is a transverse wave; the oscillations are perpendicular to the direction of propagation. Where the particles are displaced above the equilibrium position we call a peak and below we call a trough. The wavelength is the distance from one peak or trough to the next. The amplitude is the maximum distance the particle moves from its equilibrium position up or down.

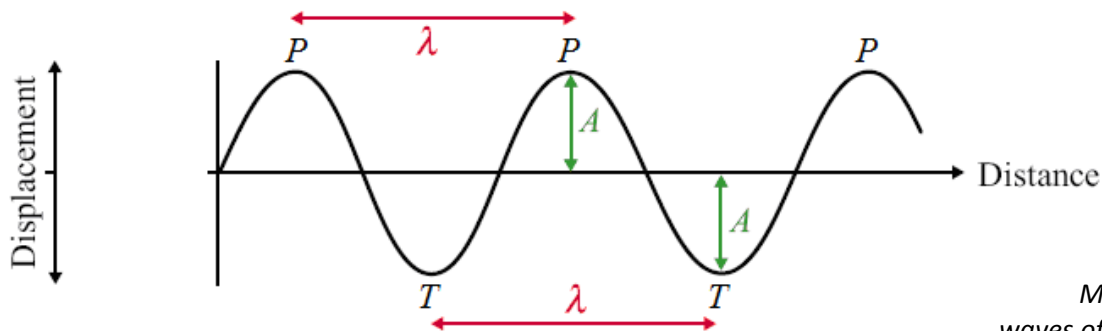

*Examples:*  
water waves,  
Mexican waves and  
waves of the EM spectrum

EM waves are produced from varying electric and magnetic field.

### Polarisation

Polarisation restricts the oscillations of a wave to one plane. In the diagrams the light is initially oscillating in all directions. A piece of Polaroid only allows light to oscillate in the same direction as it.

\* In the top diagram the light passes through a vertical plane Polaroid and becomes polarized in the vertical plane. This can then pass through the second vertical Polaroid.

\* In the middle diagram the light becomes polarized in the horizontal plane.

\* In the bottom diagram the light becomes vertically polarized but this cannot pass through a horizontal plane Polaroid.

This is proof that the waves of the EM spectrum are transverse waves. If they were longitudinal waves the forwards and backwards motion would not be stopped by crossed pieces of Polaroid; the bottom set up would emit light.

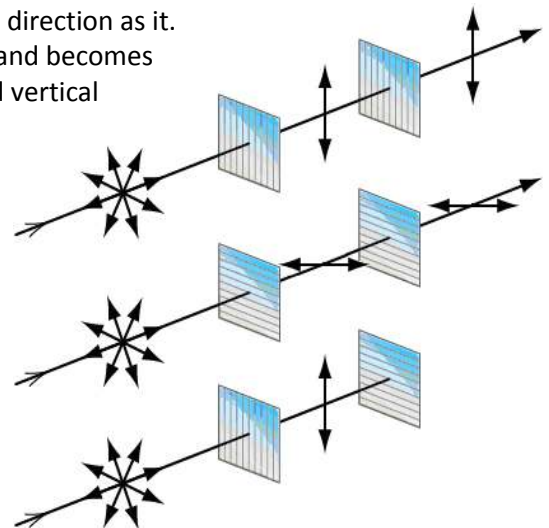

### Applications

TV aerials get the best reception when they point to the transmission source so they absorb the maximum amount of the radio waves.

Unit 4	Mr Shepherd	
	<h1>Superposition and Standing Waves</h1>	
Learning Outcomes	To know and be able to explain what standing waves are and how they are formed	
	To know what nodes and antinodes are	
	To be able to sketch the standing wave produced at different frequencies	

## Superposition

Here are two waves that have amplitudes of 1.0 travelling in opposite directions:

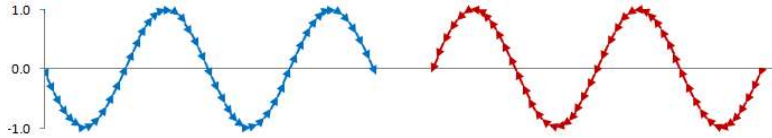

*Superposition is the process by which two waves combine into a single wave form when they overlap.*

If we add these waves together the resultant depends on where the peaks of the waves are compared to each other. Here are three examples of what the resultant could be: a wave with an amplitude of 1.5, no resultant wave at all and a wave with an amplitude of 2.0

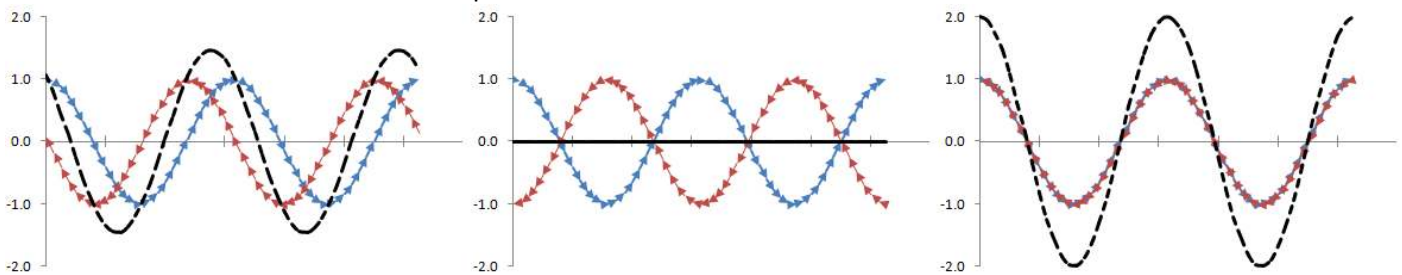

## Stationary/Standing Waves

When two similar waves travel in opposite directions they can superpose to form a standing (or stationary) wave. Here is the experimental set up of how we can form a standing wave on a string. The vibration generator sends waves down the string at a certain frequency, they reach the end of the string and reflect back at the same frequency. On their way back the two waves travelling in opposite direction superpose to form a standing wave made up of nodes and antinodes.

- Nodes** Positions on a standing wave which do not vibrate. The waves combine to give zero displacement
- Antinodes** Positions on a standing wave where there is a maximum displacement.

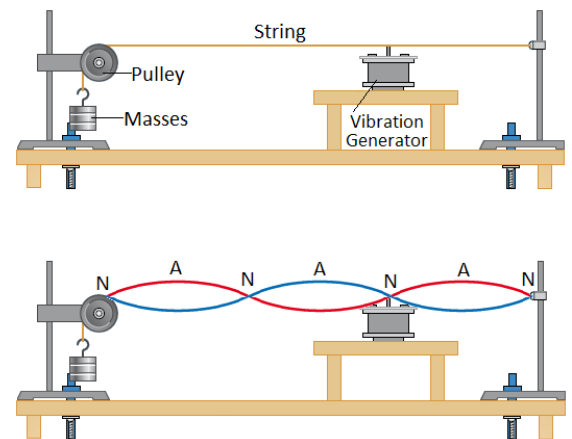

	Standing Waves	Progressive Waves
<b>Amplitude</b>	Maximum at antinode and zero at nodes	The same for all parts of the wave
<b>Frequency</b>	All parts of the wave have the same frequency	All parts of the wave have the same frequency
<b>Wavelength</b>	Twice the distance between adjacent nodes	The distance between two adjacent peaks
<b>Phase</b>	All points between two adjacent nodes in phase	Points one wavelength apart in phase
<b>Energy</b>	No energy translation	Energy translation in the direction of the wave
<b>Waveform</b>	Does not move forward	Moves forwards

## Harmonics

As we increase the frequency of the vibration generator we will see standing waves being set up. The first will occur when the generator is vibrating at the fundamental frequency,  $f_0$ , of the string.

### First Harmonic

2 nodes and 1 antinode

$$f = f_0 \quad \lambda = 2L$$

### Second Harmonic

3 nodes and 2 antinodes

$$f = 2f_0 \quad \lambda = L$$

### Third Harmonic

4 nodes and 3 antinodes

$$f = 3f_0 \quad \lambda = \frac{2}{3}L$$

### Forth Harmonic

5 nodes and 4 antinodes

$$f = 4f_0 \quad \lambda = \frac{1}{2}L$$

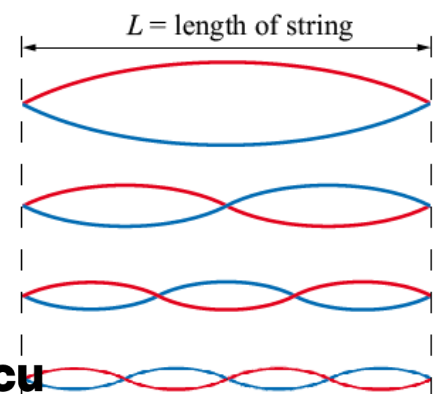

Unit 4	Mr Shepherd <b>Refraction</b>	
Learning Outcomes	To be able to calculate the refractive index of a material and to know what it tells us	
	To be able to describe and explain the direction light takes when entering a different material	
	To be able to calculate the relative refractive index of a boundary	

## Refractive Index

The refractive index of a material is a measure of how easy it is for light to travel through it. The refractive index of material  $s$  can be calculated using:

$$n = \frac{c}{c_s}$$

where  $n$  is the refractive index,  $c$  is the speed of light in a vacuum and  $c_s$  is the speed of light in material  $s$ .

**Refractive Index,  $n$ , has no units**

If light can travel at  $c$  in material  $x$  then the refractive index is:  $n = \frac{c}{c_x} \rightarrow n = \frac{c}{c} \rightarrow n = 1$

If light can travel at  $c/2$  in material  $y$  then the refractive index is:  $n = \frac{c}{c_y} \rightarrow n = \frac{c}{c/2} \rightarrow n = 2$

The higher the refractive index the slower light can travel through it  
The higher the refractive index the denser the material

## Bending Light

When light passes from one material to another it is not only the speed of the light that changes, the direction can change too.

If the ray of light is incident at  $90^\circ$  to the material then there is no change in direction, only speed.

It may help to imagine the front of the ray of light as the front of a car to

determine the direction the light will bend. Imagine a lower refractive index as grass and a higher refractive index at mud.

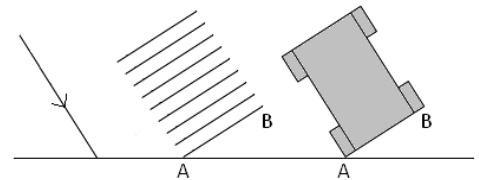

### Entering a Denser Material

The car travels on grass until tyre A reaches the mud. It is harder to move through mud so A slows down but B can keep moving at the same speed as before. The car now points in a new direction.

*Denser material – higher refractive index – bends towards the Normal*

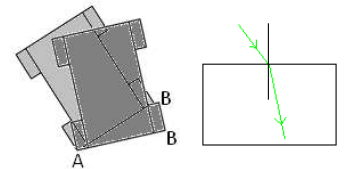

### Entering a Less Dense Material

The car travels in mud until tyre A reaches the grass. It is easier to move across grass so A can speed up but B keeps moving at the same speed as before. The car now points in a new direction.

*Less dense material – lower refractive index – bends away from the Normal*

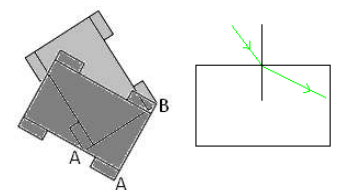

## Relative Refractive Index

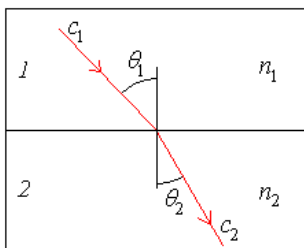

Whenever two materials touch the boundary between them will have a refractive index dependent on the refractive indices of the two materials. We call this the relative refractive index.

When light travels from material 1 to material 2 we can calculate the relative refractive index of the boundary using any of the following:

$${}_1n_2 = \frac{n_2}{n_1} = \frac{c_1}{c_2} = \frac{\sin \theta_1}{\sin \theta_2}$$

**Relative Refractive Index,  ${}_1n_2$ , has no units**

Some questions may involve light travelling through several layers of materials. Tackle one boundary at a time.

$${}_w n_g = \frac{n_g}{n_w} = \frac{c_w}{c_g} = \frac{\sin \theta_w}{\sin \theta_g}$$

$${}_g n_a = \frac{n_a}{n_g} = \frac{c_g}{c_a} = \frac{\sin \theta_g}{\sin \theta_a}$$

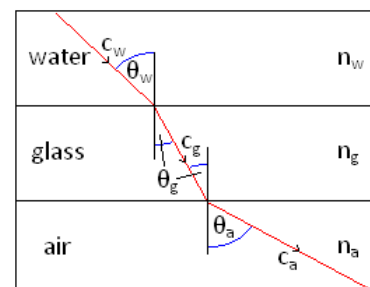

Unit 4	Mr Shepherd	
	<h1>Total Internal Reflection</h1>	
Learning Outcomes	To know what the critical angle is and be able to calculate it	
	To be able to explain what fibre optics are and how they are used	
	To be able to explain how cladding helps improve the efficiency of a fibre optic	

**Total Internal Reflection** (Also seen in GCSE Physics 3)

We know that whenever light travels from one material to another the majority of the light refracts but a small proportion of the light also reflects off the boundary and stays in the first material.

When the incident ray strikes the boundary at an angle *less than* the critical angle the light refracts into the second material.

When the incident ray strikes the boundary at an angle *equal to* the critical angle all the light is sent along the boundary between the two materials.

When the incident ray strikes the boundary at an angle *greater than* the critical angle all the light is reflected and none refracts, we say it is total internal reflection has occurred.

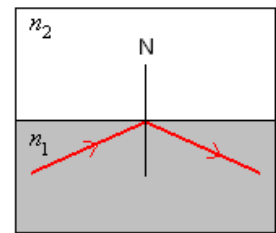
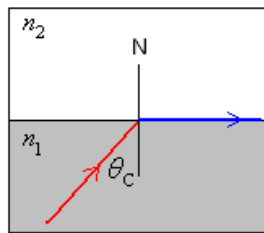
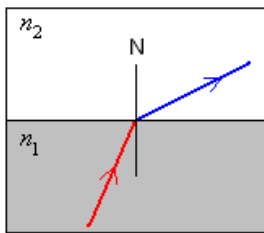

**Critical Angle** (Also seen in GCSE Physics 3)

We can derive an equation that connects the critical angle with the refractive indices of the materials.

$$\frac{\sin \theta_1}{\sin \theta_2} = \frac{n_2}{n_1} \quad \text{but at the critical angle } \theta_2 \text{ is equal to } 90^\circ \text{ which makes } \sin \theta_2 = 1 \rightarrow \frac{\sin \theta_1}{1} = \frac{n_2}{n_1}$$

$\theta_1$  is the critical angle which we represent as  $\theta_c$  making the equation:

$$\sin \theta_c = \frac{n_2}{n_1}$$

When the second material is air  $n_2 = 1$ , so the equation becomes:

$$\sin \theta_c = \frac{1}{n_1} \quad \text{or} \quad n_1 = \frac{1}{\sin \theta_c}$$

**Optical Fibres/Fibre Optics**

An optical fibre is a thin piece of flexible glass. Light can travel down it due to total internal reflection. Their uses include:

- \*Communication such as phone and TV signals: they can carry more information than electricity in copper wires.
- \*Medical endoscopes: they allow us to see down them and are flexible so they don't cause injury to the patient.

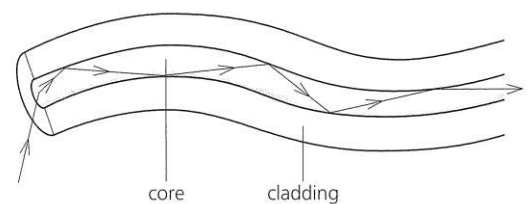

**Cladding**

Cladding is added to the outside of an optical fibre to reduce the amount of light that is lost. It does this by giving the light rays a second chance at TIR as seen in the diagram.

It does increase the critical angle but the shortest path through the optical fibre is straight through, so only letting light which stays in the core means the signal is transmitted quicker.

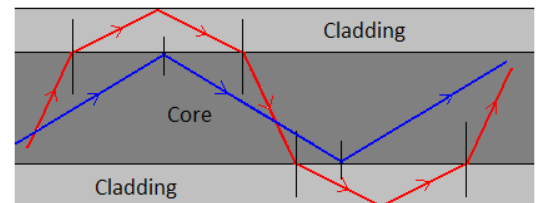

Consider the optical fibre with a refractive index of 1.5...

Without cladding $n_2 = 1$	$\sin \theta_c = \frac{n_2}{n_1}$	$\sin \theta_c = \frac{1}{1.5}$	$\theta_c = 41.8^\circ$
With cladding $n_2 = 1.4$	$\sin \theta_c = \frac{n_2}{n_1}$	$\sin \theta_c = \frac{1.4}{1.5}$	$\theta_c = 69.0^\circ$

If the cladding had a lower refractive index than the core it is easier for light to travel through so the light would bend away from the normal, **Total Internal Reflection.**

If the cladding had a higher refractive index than the core it is harder for light to travel through so the light would bend towards the normal, **Refraction.**



Unit 4	Mr Shepherd <b>Interference</b>	
Learning Outcomes	To be able to explain what interference and coherence is	
	To be able to explain Young's double slit experiment and a double source experiment	
	To be able to use the equation to describe the appearance of fringes produced	

## Interference

Interference is a special case of superposition where the waves that combine are coherent. The waves overlap and form a repeating interference pattern of maxima and minima areas. If the waves weren't coherent the interference pattern would change rapidly and continuously.

**Coherence:** Waves which are of the same frequency, wavelength, polarisation and amplitude and in a constant phase relationship. A laser is a coherent source but a light bulb is not.

**Constructive Interference:** The path difference between the waves is a whole number of wavelengths so the waves arrive in phase adding together to give a large wave. *2 peaks overlap*

**Destructive Interference:** The path difference between the waves is a half number of wavelengths so the waves arrive out of phase cancelling out to give no wave at all. *A peak and trough overlap*

## Young's Double Slit Experiment

In 1803 Thomas Young settled a debate started over 100 years earlier between Newton and Huygens by demonstrating the interference of light. Newton thought that light was made up of tiny particles called corpuscles and Huygens thought that light was a wave, Young's interference of light proves light is a wave. Here is Young's double slit set up, the two slits act as coherent sources of waves

Interference occurs where the light from the two slits overlaps. Constructive interference produces bright areas, while deconstructive interference produces dark areas. These areas are called interference fringes.

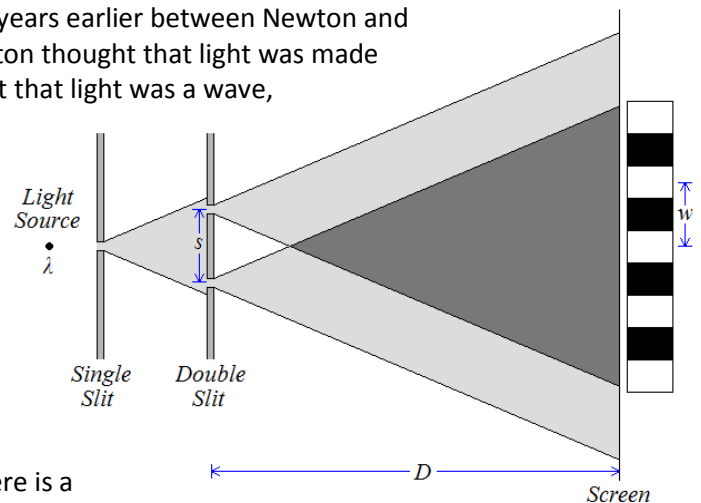

### Fringes

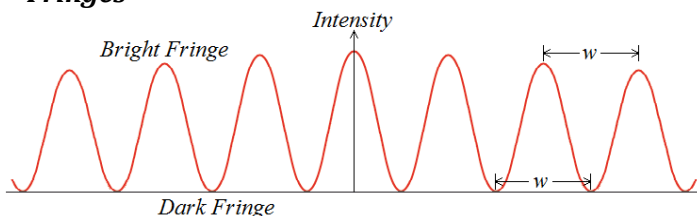

There is a central bright fringe directly behind the midpoint between the slits with more fringes evenly spaced and parallel to the slits. As we move away from the centre of the screen we see the intensity of the bright fringes decreases.

## Double Source Experiment

The interference of sound is easy to demonstrate with two speakers connected to the same signal generator. Waves of the same frequency (coherent) interfere with each other. Constructive interference produces loud fringes, while deconstructive interference produces quiet fringes.

## Derivation

We can calculate the separation of the fringes ( $w$ ) if we consider the diagram to the right which shows the first bright fringe below the central fringe. The path difference between the two waves is equal to one whole wavelength ( $\lambda$ ) for constructive interference. If the distance to the screen ( $D$ ) is massive compared to the separation of the sources ( $s$ ) the angle ( $\theta$ ) in the large triangle can be assumed the same as the angle in the smaller triangle.

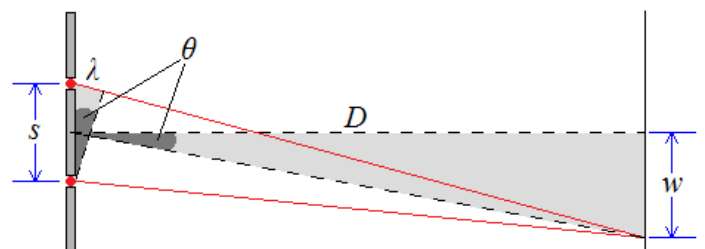

$$\sin \theta = \frac{\text{Opposite}}{\text{Hypotenuse}}$$

$$\text{For the small triangle: } \sin \theta = \frac{\lambda}{s}$$

$$\text{For the large triangle: } \sin \theta = \frac{w}{D}$$

Since the angles are the same we can write  $\frac{w}{D} = \sin \theta = \frac{\lambda}{s}$  or  $\frac{w}{D} = \frac{\lambda}{s}$  which rearranges to:

$$\boxed{w = \frac{\lambda D}{s}}$$

**Fringe Separation, Source Separation, Distance to Screen and Wavelength are measured in metres, m**

Unit 4	Mr Shepherd <b>Diffraction</b>	
Learning Outcomes	To know what diffraction is and when it happens the most	
	To be able to sketch the diffraction pattern from a single slit and a diffraction grating	
	To be able to derive $d\sin\theta=n\lambda$	

## Diffraction

When waves pass through a gap they spread out, this is called diffraction. The amount of diffraction depends on the size of the wavelength compared to the size of the gap. In the first diagram the gap is several times wider than the wavelength so the wave only spreads out a little.

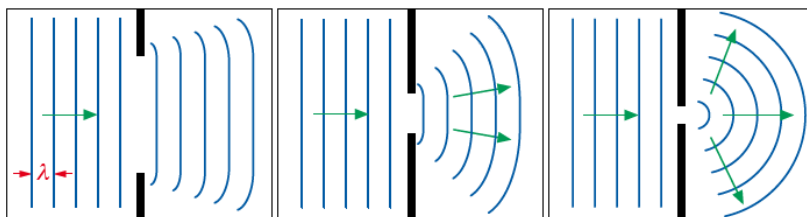

In the second diagram the gap is closer to the wavelength so it begins to spread out more.

In the third diagram the gap is now roughly the same size as the wavelength so it spreads out the most.

## Diffraction Patterns

Here is the diffraction pattern from light being shone through a single slit. There is a central maximum that is twice as wide as the others and by far the brightest. The outer fringes are dimmer and of equal width. If we use three, four or more slits the interference maxima become brighter, narrower and further apart.

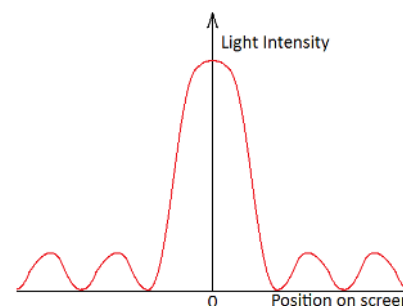

## Diffraction Grating

A diffraction grating is a series of narrow, parallel slits. They usually have around 500 slits per mm.

When light shines on the diffraction grating several bright sharp lines can be seen as shown in the diagram to the right.

The first bright line (or interference maximum) lies directly behind where the light shines on the grating. We call this the zero-order maximum. At an angle of  $\theta$  from this lies the next bright line called the first-order maximum and so forth.

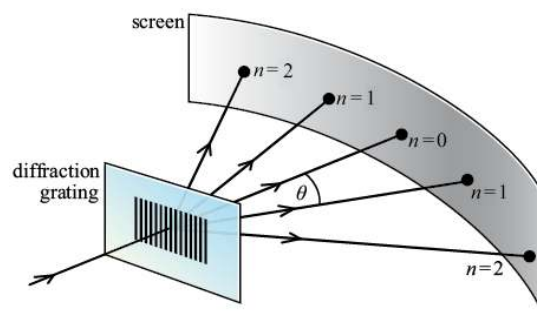

The zero-order maximum ( $n=0$ )

There is no path difference between neighbouring waves. They arrive in phase and interfere constructively.

The first-order maximum ( $n=1$ )

There is a path difference of 1 wavelength between neighbouring waves. They arrive in phase and interfere constructively.

The second-order maximum ( $n=2$ )

There is a path difference of 2 wavelengths between neighbouring waves. They arrive in phase and interfere constructively.

Between the maxima

The path difference is not a whole number of wavelengths so the waves arrive out of phase and interfere destructively.

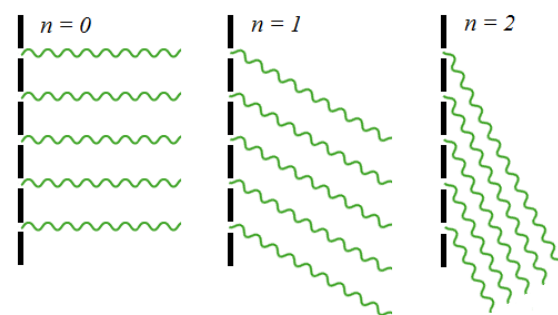

## Derivation

The angle to the maxima depends on the wavelength of the light and the separation of the slits. We can derive an equation that links them by taking a closer look at two neighbouring waves going to the first-order maximum.

The distance to the screen is so much bigger than the distance between two slits that emerging waves appear to be parallel and can be treated that way.

Consider the triangle to the right.

$$\sin \theta = \frac{\text{Opposite}}{\text{Hypotenuse}} \rightarrow \sin \theta = \frac{\lambda}{d} \rightarrow d \sin \theta = \lambda$$

For the  $n$ th order the opposite side of the triangle becomes  $n\lambda$  making the equation:

$$d \sin \theta = n\lambda$$

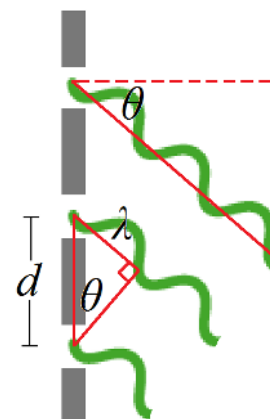

Unit 4	Mr Shepherd	
	<h1>The Photoelectric Effect</h1>	
Learning Outcomes	To know what the photoelectric effect is and how frequency and intensity affect it	
	To be able to explain what photon, photoelectron, work function and threshold frequency are	
	To be able to calculate the kinetic energy of a photoelectron	

## Observations

When light fell onto a metal plate it released electrons from the surface straight away. Increasing the intensity increased the number of electrons emitted. If the frequency of the light was lowered, no electrons were emitted at all. Increasing the intensity and giving it more time did nothing, no electrons were emitted.

### If Light was a Wave...

Increasing the intensity would increase the energy of the light. The energy from the light would be evenly spread over the metal and each electron would be given a small amount of energy. Eventually the electron would have enough energy to be removed from the metal.

## Photon

Max Planck had the idea that light could be released in 'chunks' or packets of energy. Einstein named these wave-packets photons. The energy carried by a photon is given by the equation:

$$E = hf$$

Since  $c = f\lambda$  we can also write this as:  $E = \frac{hc}{\lambda}$

## Explaining the Photoelectric Effect

Einstein suggested that one photon collides with one electron in the metal, giving it enough energy to be removed from the metal and then fly off somewhere. Some of the energy of the photon is used to break the bonds holding the electron in the metal and the rest of the energy is used by the electron to move away (kinetic energy). He represented this with the equation:  $hf = \phi + E_K$

$hf$  represents the energy of the photon,  $\phi$  is the work function and  $E_K$  is the kinetic energy.

### Work Function, $\phi$

The work function is the amount of energy the electron requires to be completely removed from the surface of the metal. This is the energy just to remove it, not to move away.

### Threshold Frequency, $f_0$

The threshold frequency is the minimum frequency that would release an electron from the surface of a metal, any less and nothing will happen.

Since  $hf = \phi + E_K$ , the minimum frequency releases an electron that is not moving, so  $E_K = 0$

$$hf_0 = \phi \quad \text{which can be rearranged to give:} \quad f_0 = \frac{\phi}{h}$$

Increasing the intensity increases the number of photons the light sources gives out each second.

If the photon has less energy than the work function an electron can not be removed. Increasing the intensity just sends out more photons, all of which would still not have enough energy to release an electron.

## Graph

If we plot a graph of the kinetic energy of the electrons against frequency we get a graph that looks like this:

Start with  $hf = \phi + E_K$  and transform into  $y = mx + c$ .

$E_K$  is the y-axis and  $f$  is the x-axis.

This makes the equation become:

$$E_K = hf - \phi$$

So the **gradient represents Planck's constant** and the **y-intercept represents (-) the work function**.

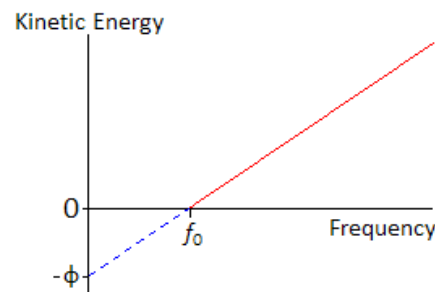

## Nightclub Analogy

We can think of the photoelectric effect in terms of a full nightclub; let the people going into the club represent the photons, the people leaving the club represent the electrons and money represent the energy.

The club is full so it is one in and one out. The work function equals the entrance fee and is £5:

If you have £3 you don't have enough to get in so noone is kicked out.

If 50 people arrive with £3 no one has enough, so one gets in and noone is kicked out.

If you have £5 you have enough to get in so someone is kicked out, but you have no money for booze.

If 50 people arrive with £5 you all get in so 50 people are kicked out, but you have no money for booze.

If you have £20 you have enough to get in so someone is kicked out and you have £15 to spend on booze.

If 50 people arrive with £20 you all get in so 50 people are kicked out and you have £15 each to spend on booze.

Unit 4	Mr Shepherd	
	<h1>Excitation, Ionisation and Energy Levels</h1>	
Learning Outcomes	To know how Bohr solved the falling electron problem	
	To be able to explain what excitation, de-excitation and ionisation are	
	To be able to calculate the frequency needed for excitation to a certain level	

## The Electronvolt, eV

The Joule is too big use on an atomic and nuclear scale so we will now use the electronvolt, represented by eV. One electronvolt is equal to the energy gained by an electron of charge  $e$ , when it is accelerated through a potential difference of 1 volt.

$$1\text{eV} = 1.6 \times 10^{-19}\text{J}$$

$$\text{eV} \rightarrow \text{J multiply by } e$$

$$1\text{J} = 6.25 \times 10^{18}\text{eV}$$

$$\text{J} \rightarrow \text{eV divide by } e$$

## The Problem with Atoms

Rutherford's nuclear model of the atom leaves us with a problem: a charged particle emits radiation when it accelerates. This would mean that the electrons would fall into the nucleus.

### Bohr to the Rescue

Niels Bohr solved this problem by suggesting that the electrons could only orbit the nucleus in certain 'allowed' energy levels. He suggested that an electron may only transfer energy when it moves from one energy level to another. A change from one level to another is called a 'transition'.

To move up and energy level the electron must gain the exact amount of energy to make the transition.

It can do this by another electron colliding with it or by absorbing a photon of the exact energy.

When moving down a level the electron must lose the exact amount of energy when making the transition.

It releases this energy as a photon of energy equal to the energy it loses.

$$\Delta E = hf = E_1 - E_2$$

$E_1$  is the energy of the level the electron starts at and  $E_2$  is the energy of the level the electron ends at

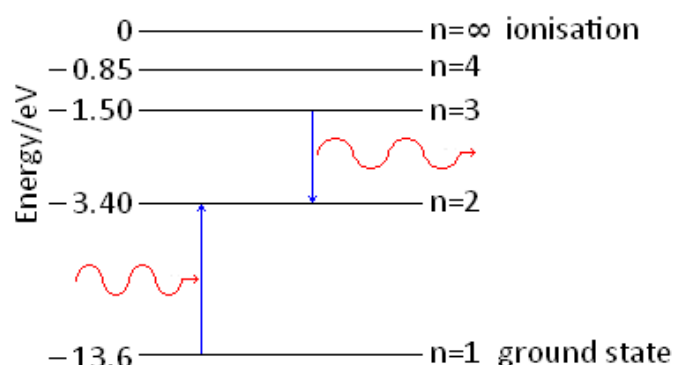
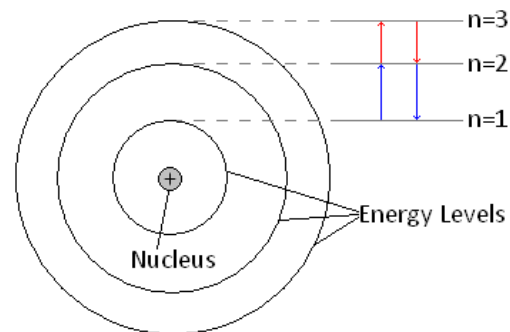

### Excitation

When an electron gains the exact amount of energy to move up one or more energy levels

### De-excitation

When an electron gives out the exact amount of energy to move back down to its original energy level

### Ionisation

An electron can gain enough energy to be completely removed from the atom.

The ground state and the energy levels leading up to ionisation have negative values of energy, this is because they are compared to the ionisation level. Remember that energy must be given to the electrons to move up a level and is lost (or given out) when it moves down a level.

## Line Spectra

Atoms of the same element have same energy levels. Each transition releases a photon with a set amount of energy meaning the frequency and wavelength are also set. The wavelength of light is responsible for colour it is. We can analyse the light by using a diffraction grating to separate light into the colours that

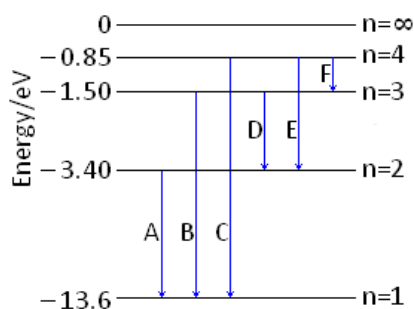

makes it up, called its *line spectra*. Each element has its own line spectra like a barcode.

To the above right are the line spectra of Hydrogen and Helium.

We can calculate the energy difference that created the colour.

If we know the energy differences for each element we can work out which element is responsible for the light and hence deduce which elements are present.

We can see that there are 6 possible transitions in the diagram to the left, A to F.

D has an energy difference of  $1.9 \text{ eV}$  or  $3.04 \times 10^{-19} \text{ J}$  which corresponds to a frequency of  $4.59 \times 10^{14} \text{ Hz}$  and a wavelength of  $654 \text{ nm}$  – red.

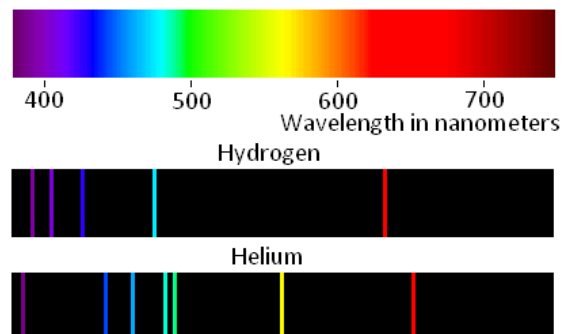

Unit 4	Mr Shepherd	
	<h1>Wave-Particle Duality</h1>	
Learning Outcomes	To know how to calculate the de Broglie wavelength and what is it	
	To be able to explain what electron diffraction shows us	
	To know what wave-particle duality is	

## De Broglie

In 1923 Louis de Broglie put forward the idea that 'all particles have a wave nature' meaning that particles can behave like waves.

This doesn't sound too far fetched after Einstein proved that a wave can behave like a particle.

De Broglie said that all particles could have a wavelength. A particle of mass,  $m$ , that is travelling at velocity,  $v$ , would have a wavelength given by:

$$\lambda = \frac{h}{mv} \text{ which is sometime written as } \lambda = \frac{h}{p} \text{ where } p \text{ is momentum}$$

This wavelength is called the de Broglie wavelength. The modern view is that the de Broglie wavelength is linked to the probability of finding the particle at a certain point in space.

**De Broglie wavelength is measured in metres, m**

## Electron Diffraction

Two years after de Broglie came up with his particle wavelengths and idea that electrons could diffract, Davisson and Germer proved this to happen.

They fired electrons into a crystal structure which acted as a diffraction grating. This produced areas of electrons and no electrons on the screen behind it, just like the pattern you get when light diffracts.

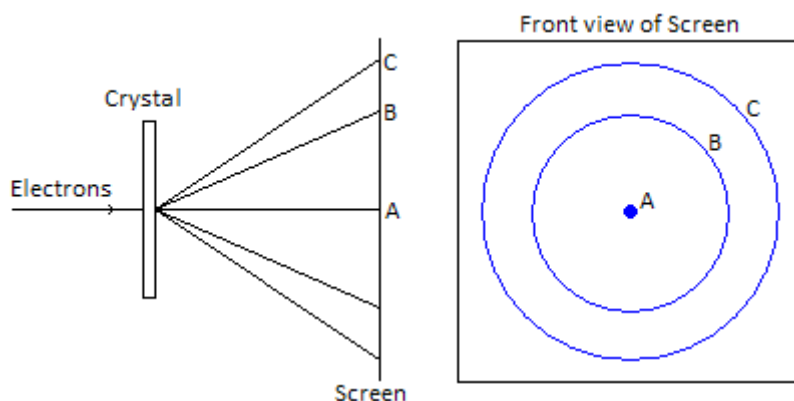

## Electron Wavelength

We can calculate the de Broglie wavelength of an electron from the potential difference,  $V$ , that accelerated it. Change in electric potential energy gained =  $eV$

This is equal to the kinetic energy of the electron

$$eV = \frac{1}{2}mv^2$$

The velocity is therefore given by:

$$\sqrt{\frac{2eV}{m}} = v$$

We can substitute this into  $\lambda = \frac{h}{mv}$  to get:

$$\lambda = \frac{h}{\sqrt{2meV}}$$

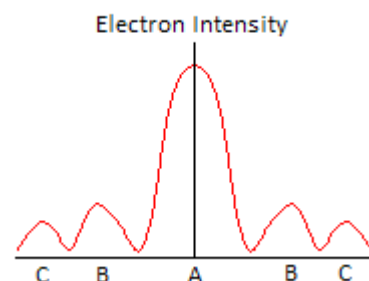

## Sand Analogy

If we compare a double slit electron diffraction to sand falling from containers we can see how crazy electron diffraction is. Imagine two holes about 30cm apart that sand is dropping from. We would expect to find a maximum amount of sand under each hole, right? This is not what we find! We find a maximum in between the two holes. The electrons are acting like a wave.

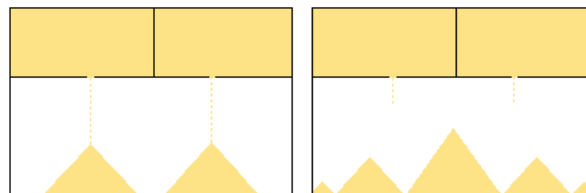

## Wave-Particle Duality

Wave-particle duality means that waves sometimes behave like particles and particles sometimes behave like waves. Some examples of these are shown below:

### Light as a Wave

Diffraction, interference, polarisation and refraction all prove that light is a wave and will be covered in Unit 2.

### Light as a Particle

We have seen that the photoelectric effect shows that light can behave as a particle called a photon.

### Electron as a Particle

The deflection by an electromagnetic field and collisions with other particles show its particle nature.

### Electron as a Wave

Electron diffraction proves that a particle can show wave behaviour.

# A2 Physics

## Unit 5

### Fields and Further Mechanics

- 3 Circular Motion
- 4 Centripetal Force and Acceleration
- 5 Simple Harmonic Motion
- 6 SHM Graphs
- 7 SHM Time Periods
- 8 Resonance and Damping
- 9 Gravitational Fields
- 10 Gravitational Potential
- 11 Orbits and Escape Velocity
- 12 Electric Fields
- 13 Electric Potential
- 14 Fields Comparison
- 15 Capacitors
- 16 Charging and Discharging
- 17 Exponential Decay
- 18 Force on a Current Carrying Wire
- 19 Force on a Charged Particle
- 20 Magnetic Flux and Flux Linkage
- 21 Electromagnetic Induction
- 22 Transformers

## Unit 6

### Nuclear and Thermal Physics

- 1 Constituents of the Atom
- 2 Particles and Antiparticles
- 3 Quarks
- 4 Hadrons
- 5 Leptons
- 6 Forces and Exchange Particles
- 7 The Strong Interaction
- 8 The Weak Interaction
- 9 Feynman Diagrams
- 1 Rutherford Scattering
- 2 Ionising Radiation
- 3 Radioactive Decay
- 4 Modes of Decay
- 5 Nuclear Radius
- 6 Mass and Energy
- 7 Fission and Fusion
- 8 Nuclear Reactors
- 9 Nuclear Safety Aspects
- 10 Heat, Temperature and Internal Energy
- 11 The Specifics
- 12 Gas Laws
- 13 Ideal Gas
- 14 Molecular Kinetic Theory Model

Unit 5	Mr Shepherd	
	<b>Heat, Temperature and Internal Energy</b>	
Learning Outcomes	To know what internal energy is	
	To be able to explain the difference between heat, temperature and internal energy	
	To be able to explain what absolute zero is and how it was found	

## Internal Energy

The internal energy of a substance is due to the vibrations/movement energy of the particles (kinetic) and the energy due to the bonds holding them together (potential).

**Solids:** In a solid the particles are arranged in a regular fixed structure, they cannot move from their position in the structure but can vibrate. The internal energy of a solid is due to the kinetic energy of the vibrating particles and the potential energy from the bonds between them.

**Liquids:** In a liquid the particles vibrate and are free to move around but are still in contact with each other. The forces between them are less than when in solid form. The internal energy of a liquid is due to the kinetic and potential energies of the particles but since they are free to slide past each other the potential energy is less than that of it in solid form.

**Gases:** In a gas particles are free to move in all directions with high speeds. There are almost no forces of attraction between them. The internal energy of a gas is almost entirely due to the kinetic energy of the particles.

## Temperature

Temperature is a measure of the kinetic energies of the particles in the substance. As we can see from the graph something with a high temperature means the particles are vibrating/moving with higher average speeds that a substance at a lower temperature. It is possible for two objects/substances to be at the same temperature but have different internal energies. We will go into this further in the next lesson: The Specifics.

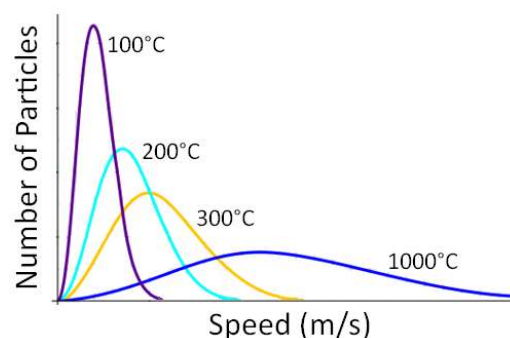

## Heat

Heat is the flow of thermal energy and it flows from a high temperature to a low temperature.

If two objects are at the same temperature we say that they are in thermal equilibrium and no heat flows.

*If object A is in thermal equilibrium with object B and object B is in thermal equilibrium with object C then A and C must be in thermal equilibrium with each other.*

Get into a hot or cold bath and energy is transferred:

In a cold bath thermal energy is transferred from your body to the water.

In a hot bath thermal energy is transferred from the water to your body.

As the energy is transferred you and the water become the same temperature. When this happens there is no longer a flow of energy → so no more heat. You both still have a temperature due to the vibrations of your particles but there is no longer a temperature difference so there is no longer a flow of energy.

## Temperature Scale

The Celsius scale was established by giving the temperature at which water becomes ice a value of 0 and the temperature at which it boils a value of 100. Using these fixed points a scale was created.

## Absolute Zero and Kelvins

In 1848 William Thomson came up with the Kelvin scale for temperature. He measured the pressure caused by gases at known temperatures (in °C) and plotted the results. He found a graph like this one.

By extrapolating his results he found the temperature at which a gas would exert zero pressure. Since pressure is caused by the collisions of the gas particles with the container, zero pressure means the particles are not moving and have a minimum internal energy. At this point the particle stops moving completely and we call this temperature absolute zero, it is not possible to get any colder. This temperature is -273°C.

1 Kelvin is the same size as 1 degree Celsius but the Kelvin scale starts at absolute zero.

$$^{\circ}\text{C} = \text{K} - 273$$

$$\text{K} = ^{\circ}\text{C} + 273$$

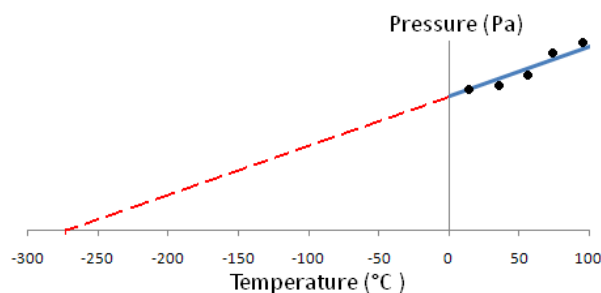

Unit 5	Mr Shepherd <b>The Specifics</b>	
Learning Outcomes	To be able to explain and calculate specific heat capacity	
	To be able to explain and calculate specific latent heat	
	To know the correct units to use and the assumptions we make in energy transfer	

## Specific Heat Capacity

We know that when we heat a substance the temperature will increase. The equation that links heat (energy) and temperature is:

$$\Delta Q = mc\Delta T$$

$c$  is the specific heat capacity which is the energy required to raise the temperature of 1 kg of a substance by 1 degree. It can be thought of as the heat energy 1 kg of the substance can hold before the temperature will increase by 1 degree.

**Specific Heat Capacity is measured in Joules per kilogram per Kelvin, J/kg K or J kg<sup>-1</sup> K<sup>-1</sup>**

## Water Analogy

We can think of the energy being transferred as volume of water. Consider two substances: one with a high heat capacity represented by 250 ml beakers and one with a low heat capacity represented by 100 ml beakers. When a beaker is full the temperature of the substance will increase by 1 degree.

We can see that 2 litres of water will fill 8 of the 250 ml beakers or 20 of the 100ml beakers meaning the same amount of energy can raise the temperature of the first substance by 8 degrees or the second by 20 degrees.

## Changes of State

When a substance changes state there is no change in temperature.

When a solid is heated energy is transferred to the particles making them vibrate more which means the temperature increases. The potential energy of the solid remains constant but the kinetic energy increases.

At melting point the particles do not vibrate any faster, meaning the kinetic energy and temperature are constant. The bonds that keep the particles in a rigid shape are broken and the potential energy increases.

In liquid form the particles are still in contact with each other but can slide past each other. As more energy is transferred the particles vibrate more. The kinetic energy increases but the potential energy is constant.

At boiling point the particles do not vibrate any faster, meaning the kinetic energy and temperature are constant. The bonds holding the particles together are all broken, this takes much more energy than when melting since all the bonds need to be broken.

When a gas is heated the particles move faster, meaning the kinetic energy and temperature increases. The potential energy stays constant.

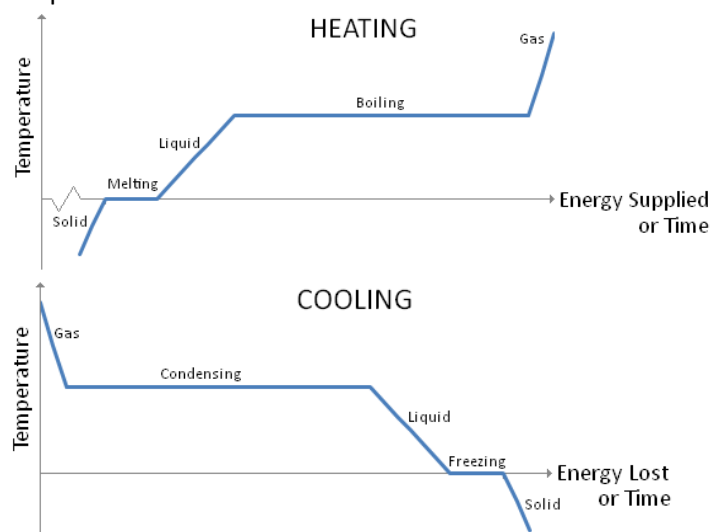

## Specific Latent Heat

Different substances require different amounts of energy to change them from solid to liquid and from liquid to gas. The energy required is given by the equation:

$$Q = ml$$

$l$  represents the specific latent heat which is the energy required to change 1 kg of a substance from solid to liquid or liquid to gas without a change in temperature.

**Specific Latent Heat is measured in Joules per kilogram, J/kg or J kg<sup>-1</sup>**

The specific latent heat of fusion is the energy required to change 1 kg of solid into liquid

The specific latent heat of vaporisation is the energy required to change 1 kg of liquid into gas.

As we have just discussed, changing from a liquid to a gas takes more energy than changing a solid into a gas, so the specific latent heat of vaporisation is higher than the specific latent heat of fusion.



Unit 5	Mr Shepherd	
	<h1>Gas Laws</h1>	
Learning Outcomes	To know and be able to use the correct units for volume, temperature and pressure	
	To be able to state Boyle's Charles' and the Pressure law for gases	
	To be able to sketch the graphs that show these laws	

## Gas Properties

Volume,  $V$ : This is the space occupied by the particles that make up the gas.

**Volume is measured in metres cubed,  $m^3$**

Temperature,  $T$ : This is a measure of the internal energy of the gas and this is equal to the average kinetic energy of its particles.

**Temperature is measured in Kelvin, K**

Pressure,  $p$ : When a gas particle collides with the walls of its container it causes a pressure. Pressure is given by the equation pressure = Force/Area or 'force per unit area'.

**Pressure is measured in pascals, Pa**

1 pascal is equal to a pressure of 1 newton per square metre.

## Understanding the Gas Laws

We are about to look at the three different laws that all gases obey. To help us understand them let us apply each one to a simple model. Imagine one ball in a box; the pressure is a measure of how many collisions between the ball and the box happen in a certain time, the volume is the area of the box and the temperature is the average speed of the ball. To simply thing further let us assume it is only moving back and forth in the x direction.

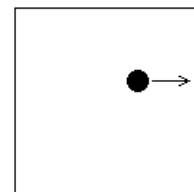

### Boyle's Law

The pressure of a fixed mass of gas is inversely proportional to its volume when kept at a constant temperature.

$$p \propto \frac{1}{V} \text{ for constant } T$$

#### Think about it...

If temperature is constant this means that the ball is travelling at a fixed, constant speed. If we increase the size of the box it makes fewer collisions in the same time because it has to travel further before it collides with the side. If we make the box smaller the ball will collide with the box more often since it has less distance to travel.

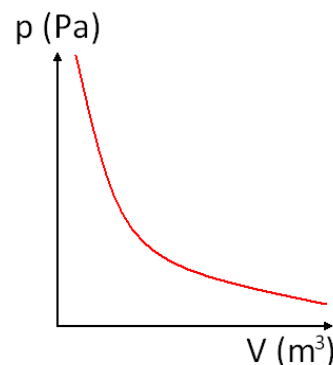

### Charles' Law

All gases expand at the same rate when heated. The volume of a fixed mass of gas is proportional to its temperature when kept at a constant pressure.

$$V \propto T \text{ for constant } p$$

#### Think about it...

If pressure is constant that means that the same number of collisions with the box are taking place. So if the box was made bigger the ball would have to move faster to make sure there were the same amount of collisions per unit time.

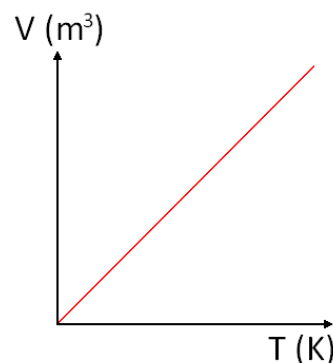

### The Pressure Law

The pressure of a fixed mass of gas is proportional to its temperature when kept at a constant volume.

$$p \propto T \text{ for constant } V$$

#### Think about it...

If the volume is constant it means the box has a fixed size. If we increase the speed at which the ball is moving it will hit the sides of the box more often. If we slow the ball down it will hit the sides less often.

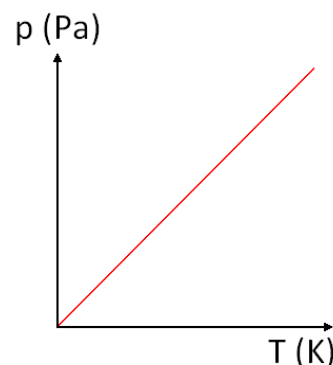

Unit 5	Mr Shepherd	
	<b>Ideal Gases</b>	
Learning Outcomes	To be able to calculate the pressure, volume or temperature of a gas	
	To know and be able to use the ideal gas equation	
	To know the significance of Avogadro's constant, Boltzmann's constant and moles	

### Messing with Gases

The three gas laws can be combined to give us the equation:  $pV \propto T$

We can rearrange this to give:  $\frac{pV}{T} = \text{constant}$

We can use this to derive a very useful equation to compare the pressure, volume and temperature of a gas

that is changed from one state ( $p_1, V_1, T_1$ ) to another ( $p_2, V_2, T_2$ ).

$$\frac{p_1 V_1}{T_1} = \frac{p_2 V_2}{T_2}$$

**Temperatures must be in Kelvin, K**

### Avogadro and the Mole

One mole of a material has a mass of  $M$  grams, where  $M$  is the molecular mass in atomic mass units, u. Oxygen has a molecular mass of 16, so 1 mole of Oxygen atoms has a mass of 16g, 2 moles has a mass of 32g and so on. An Oxygen molecule is made of two atoms so it has a molecular mass of 32g. This means 16g would be half a mole of Oxygen molecules.

$$n = \frac{m}{M}$$

where  $n$  is the number of moles,  $m$  is the mass and  $M$  is the molecular mass.

Avogadro suggested that one mole of any substance contains the same number of particles, he found this to be  $6.02 \times 10^{23}$ . This gives us a second way of calculating the number of moles

$$n = \frac{N}{N_A}$$

where  $N$  is the number of particles and  $N_A$  is the Avogadro constant.

**$N_A$  is the Avogadro Constant,  $N_A = 6.02 \times 10^{23} \text{ mol}^{-1}$**

### Ideal Gases

We know from the three gas laws that  $\frac{pV}{T} = \text{constant}$

Ideal gases all behave in the same way so we can assign a letter to the constant. The equation becomes:

$$\frac{pV}{T} = R$$

If the volume and temperature of a gas are kept constant then the pressure depends on  $R$  and the number of particles in the container. We must take account of this by bringing the number of moles,  $n$ , into the equation:

$$\frac{pV}{T} = nR \quad \rightarrow \quad \boxed{pV = nRT}$$

**$R$  is the Molar Gas Constant,  $R = 8.31 \text{ J K}^{-1} \text{ mol}^{-1}$**

This is called the *equation of state* for an ideal gas. The concept of ideal gases is used to approximate the behaviour of real gases. Real gases can become liquids at low temperatures and high pressures.

Using the Avogadro's equation for  $n$  we can derive a new equation for an ideal gas:

$$pV = nRT \quad \rightarrow \quad pV = \frac{N}{N_A} RT \quad \rightarrow \quad \boxed{pV = N \frac{R}{N_A} T}$$

### Boltzmann Constant - cheeky!

Boltzmann noticed that  $R$  and  $N_A$  in the above equation are constants, so dividing one by the other will always give the same answer. The Boltzmann constant is represented by  $k$  and is given as

$$\frac{R}{N_A} = k$$

**$k$  is the Boltzmann Constant,  $k = 1.38 \times 10^{-23} \text{ J K}^{-1}$**

$pV = nRT$  can become  $pV = N \frac{R}{N_A} T$  which can also be written as

$$\boxed{pV = NkT}$$

This document is available free of charge on



Unit 5	Mr Shepherd	
	<h1>Molecular Kinetic Theory Model</h1>	
Learning Outcomes	To be able to list the assumptions needed to derive an equation for the pressure of a gas	
	To be able to derive an equation for the pressure of a gas	
	To be able to calculate the mean kinetic energy of a gas molecule	

## Assumptions

1. There are a very large number of molecules ( $N$ )
2. Molecules have negligible volume compared to the container
3. The molecules show random motion (ranges of speeds and directions)
4. Newton's Laws of Motion can be applied to the molecules
5. Collisions are elastic and happen quickly compared to the time between collisions
6. There are no intermolecular forces acting other than when they collide

## The Big, Bad Derivation

The molecules move in all directions. Let us start with one molecule of mass  $m$  travelling with velocity  $v_x$ . It collides with the walls of the container, each wall has a length of  $L$ .

Calculate the change in momentum: before it moves with velocity  $v_x$  and after the collision it move with  $-v_x$ .

$$\Delta mv = (mv_x) - (-mv_x) \rightarrow \boxed{\Delta mv = 2mv_x} \text{ Equation 1}$$

The time can be given by using distance/speed: the speed is  $v_x$  and the distance is twice the length of the box

(the distance to collide and then collide again with the same wall)  $t = \frac{2L}{v_x}$  Equation 2

Force can be calculated by:  $F = \frac{\Delta mv}{\Delta t}$  Substitute in Equation 1 and 2  $\rightarrow F = \frac{2mv_x}{\left(\frac{2L}{v_x}\right)} \rightarrow F = 2mv_x \left(\frac{v_x}{2L}\right)$

$\rightarrow \boxed{F = \frac{mv_x^2}{L}}$  Equation 3, gives the force of one molecule acting on the side of the container.

We can now calculate the **pressure** this one molecule causes in the x direction:

$$p = \frac{F}{A} \text{ Substituting Equation 3 } \rightarrow p = \frac{mv_x^2/L}{L^2} \rightarrow p = \frac{mv_x^2}{L^3} \rightarrow p = \frac{mv_x^2}{V} \text{ Equation 4}$$

(if we assume that the box is a cube, we can **replace**  $L^3$  with  $V$ , both units are  $m^3$ )

All the molecules of the gas have different speeds in the x direction. We can find the pressure in the x direction due to them all by first using the mean value of  $v_x$  and then multiplying it by  $N$ , the total number of

molecules:  $p = \frac{mv_x^2}{V} \rightarrow p = \frac{\overline{mv_x^2}}{V}$   $\boxed{p = \frac{Nm\overline{v_x^2}}{V}}$  Equation 5

Equation 5 gives us the pressure in the x direction.

The mean speed in all directions is given by:  $\rightarrow \overline{c^2} = \overline{v_x^2} + \overline{v_y^2} + \overline{v_z^2}$  But since the average velocities in all directions are equal:  $\rightarrow \overline{c^2} = 3\overline{v_x^2}$   
 $\frac{\overline{c^2}}{3} = \overline{v_x^2}$

We can substitute this into the Equation 5 for pressure above:

$$p = \frac{Nm\overline{v_x^2}}{V} \rightarrow pV = Nm\overline{v_x^2} \rightarrow pV = Nm\frac{\overline{c^2}}{3} \rightarrow \boxed{pV = \frac{1}{3}Nmc^2} \text{ Equation 6}$$

## Kinetic Energy of a Gas

From the equation we have just derived we can find an equation for the mean kinetic energy of a gas:

Since  $pV = \frac{1}{3}Nmc^2$  and  $pV = nRT$  combine these to get  $\boxed{\frac{1}{3}Nmc^2 = nRT}$  Equation 7

Kinetic energy is given by  $E_K = \frac{1}{2}mv^2$  so we need to make the above equation look the same.

$$\frac{1}{3}Nmc^2 = nRT \rightarrow \frac{1}{3}mc^2 = \frac{nRT}{N} \rightarrow mc^2 = \frac{3nRT}{N} \rightarrow \frac{1}{2}mc^2 = \frac{3nRT}{2N}$$

$$n = \frac{N}{N_A} \rightarrow N_A = \frac{N}{n} \rightarrow \frac{1}{N_A} = \frac{n}{N} \rightarrow \frac{1}{2}mc^2 = \frac{3RT}{2N_A}$$

Don't forget that cheeky chap Boltzmann  $k = \frac{R}{N_A} \rightarrow \boxed{\frac{1}{2}mc^2 = \frac{3}{2}kT}$  Equation 8

Unit 5	Mr Shepherd <b>Circular Motion</b>	
Learning Outcomes	To be able to calculate the angular displacement of an object moving in a circle	
	To be able to calculate the angular speed of an object moving in a circle	
	To be able to calculate the speed of an object moving in a circle	

To the right is the path a car is taking as it moves in a circle of radius  $r$ .

### Angular Displacement, $\theta$

As the car travels from X to Y it has travelled a distance of  $s$  and has covered a section of the complete circle it will make. It has covered an angle of  $\theta$  which is called the angular displacement.

$$\theta = \frac{\text{arc}}{\text{radius}}$$

$$\theta = \frac{s}{r}$$

Angular Displacement is measured in radians, rad

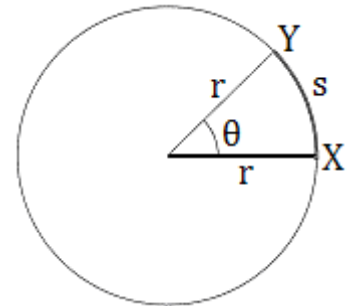

### Radians

1 radian is the angle made when the arc of a circle is equal to the radius.

$$\text{For a complete circle } \theta = \frac{\text{arc}}{\text{radius}} \rightarrow \theta = \frac{\text{circumference}}{\text{radius}} \rightarrow \theta = \frac{2\pi r}{r} \rightarrow \theta = 2\pi$$

A complete circle is  $360^\circ$  so

$$360^\circ = 2\pi \text{ rad}$$

$$1^\circ = 0.017 \text{ rad}$$

$$57.3^\circ = 1 \text{ rad}$$

### Angular Speed, $\omega$

Angular speed is the rate of change of angular displacement, or the angle that is covered every second.

$$\omega = \frac{\theta}{t}$$

Angular Speed is measured in radians per second, rad/s or  $\text{rad s}^{-1}$

### Frequency, $f$

Frequency is the number of complete circles that occur every second.

For one circle;  $\theta = 2\pi$ , if we substitute this into the equation above we get

$$\omega = \frac{2\pi}{t}$$

This equation says that the angular speed (angle made per second) is equal to one circle divided by the time taken to do it. Very similar to speed = distance/time

Since  $f = \frac{1}{T}$  the above equation can be written as  $\omega = 2\pi f$

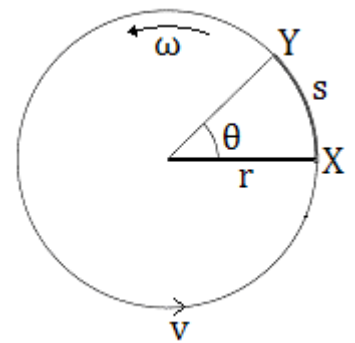

Frequency is measured in Hertz, Hz

### Speed, $v$

The velocity of the car is constantly changing because the direction is constantly changing. The speed however, is constant and can be calculated.

$$v = \frac{s}{t}$$

If we rearrange the top equation we can get  $r\theta = s$ , the speed then becomes

$$v = \frac{r\theta}{t}$$

Now if we rearrange the second equation we get  $\omega t = \theta$ , the equation becomes

$$v = \frac{r\omega t}{t}$$

Cancel the  $t$ 's and we finally arrive at our equation for the speed.

$$v = r\omega$$

Speed is measured in metres per second, m/s or  $\text{m s}^{-1}$



Unit 5	Mr Shepherd	
	<h1>Centripetal Force and Acceleration</h1>	
Learning Outcomes	To be able to calculate the centripetal acceleration of an object moving in a circle	
	To be able to calculate the centripetal force that keeps an object moving in a circle	
	To be able to explain why the centrifugal force does not exist	

### Moving in a Circle *(Also seen in GCSE Physics 3)*

For an object to continue to move in a circle a force is needed that acts on the object towards the centre of the circle. This is called the centripetal force and is provided by a number of things:

For a satellite orbiting the Earth it is provided by gravitational attraction.

For a car driving around a roundabout it is provided by the friction between the wheels and the road.

For a ball on a string being swung in a circle it is provided by the tension in the string.

**Centripetal force acts from the body to the centre of a circle**

Since  $F=ma$  the object must accelerate in the same direction as the resultant force. The object is constantly changing its direction towards the centre of the circle.

**Centripetal acceleration has direction from the body to the centre of the circle**

### Centrifugal Force

Some people thought that an object moving in a circle would experience the centripetal force acting from the object towards the centre of the circle and the centrifugal force acting from the object away from the centre of the circle.

They thought this because if you sit on a roundabout as it spins it feels like you are being thrown off backwards. If someone was watching from the side they would see you try and move in a straight line but be pulled in a circle by the roundabout.

The centrifugal force does not exist in these situations.

### Centripetal Acceleration

The centripetal acceleration of an object can be derived if we look at the situation to the right. An object of speed  $v$  makes an angular displacement of  $\Delta\theta$  in time  $\Delta t$ .

$$a = \frac{\Delta v}{\Delta t}$$

If we look at the triangle at the far right we can use

$$\theta = \frac{s}{r} \text{ when } \theta \text{ is small. This becomes: } \Delta\theta = \frac{\Delta v}{v}$$

We can rearrange this to give:  $v\Delta\theta = \Delta v$

Acceleration is given by  $a = \frac{\Delta v}{\Delta t}$  substitute the above equation into this one

$$a = \frac{v\Delta\theta}{\Delta t} \text{ this is the same as } a = v \frac{\Delta\theta}{\Delta t}$$

In lesson 3 (Circular Motion) we established that  $\omega = \frac{\Delta\theta}{\Delta t}$ , substitute this into the equation above

$$a = v\omega$$

If we use  $v = r\omega$  we can derive two more equations for acceleration

$$\boxed{a = v\omega}$$

$$\boxed{a = r\omega^2}$$

$$\boxed{a = \frac{v^2}{r}}$$

**Centripetal Acceleration is measured in metres per second squared,  $m/s^2$  or  $m s^{-2}$**

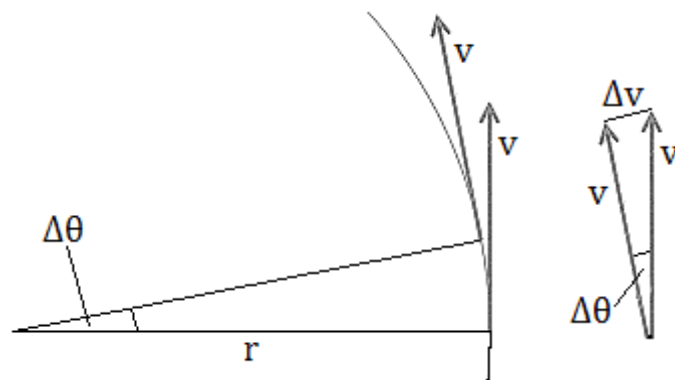

### Centripetal Force

We can derive three equations for the centripetal force by using  $F = ma$  and the three equations of acceleration from above.

$$\boxed{F = mv\omega}$$

$$\boxed{F = mr\omega^2}$$

$$\boxed{F = m \frac{v^2}{r}}$$

**Centripetal Force is measured in Newtons, N**

Unit 5	Mr Shepherd		<h1>Simple Harmonic Motion</h1>
Learning Outcomes	To know what simple harmonic motion is		
	To be able to describe the acceleration of an SHM system		
	To be able to calculate the displacement, velocity and acceleration of an SHM system		

## Oscillations

In each of the cases below there is something that is oscillating, it vibrates back and forth or up and down. Each of these systems is demonstrating Simple Harmonic Motion (SHM).

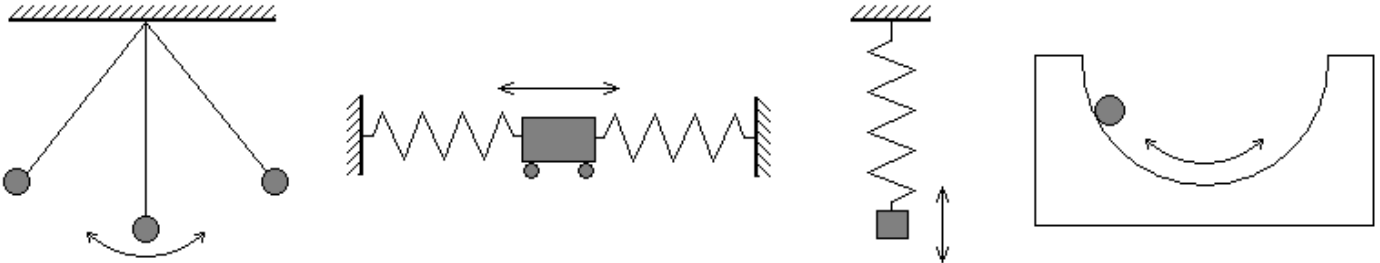

## SHM Characteristics

The equilibrium point is where the object comes to rest, in the simple pendulum it is at its lowest point. If we displace the object by a displacement of  $x$  there will be a force that brings the object back to the equilibrium point. We call this the restoring force and it always acts in the opposite direction to the displacement.

We can represent this as:  $F \propto -x$   
 Since  $F = ma$  we can also write:  $a \propto -x$

For an object to be moving with simple harmonic motion, its acceleration must satisfy two conditions:

- \*The acceleration is proportional to the displacement
- \*The acceleration is in the opposite direction to the displacement (towards the equilibrium point)

## Equations

The following equations are true for all SHM systems but let us use the simple pendulum when thinking about them.

The pendulum bob is displaced in the negative direction when at point 1, it is released and swings through point 2 at its maximum speed until it reaches point 3 where it comes to a complete stop. It then swings to the negative direction, reaches a maximum speed at 4 and completes a full cycle when it stops at 5.

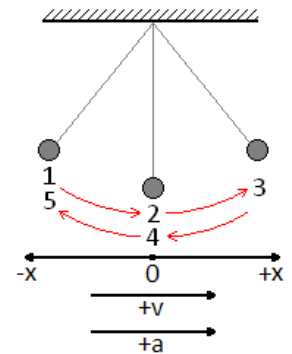

## Displacement, $x$

The displacement of the bob after a time  $t$  is given by the equation:

$$x = A \cos 2\pi f t \quad (\text{CALCS IN RAD})$$

Since  $f = \frac{1}{T}$  the equation can become:  $x = A \cos 2\pi \frac{1}{T} t \rightarrow x = A \cos 2\pi \frac{t}{T}$

(where  $t$  is the time into the cycle and  $T$  is the time for one complete cycle)

The maximum displacement is called the amplitude,  $A$ .

$$x = A \quad \leftarrow \text{MAXIMUM}$$

## Velocity, $v$

The velocity of the bob at a displacement of  $x$  is given by the equation:

$$v = \pm 2\pi f \sqrt{A^2 - x^2}$$

The maximum velocity occurs in the middle of the swing (2 and 4) when displacement is zero ( $x = 0$ )

$$v = \pm 2\pi f \sqrt{A^2 - x^2} \rightarrow v = \pm 2\pi f \sqrt{A^2 - 0^2} \rightarrow v = \pm 2\pi f \sqrt{A^2} \rightarrow v = \pm 2\pi f A \quad \leftarrow \text{MAXIMUM}$$

## Acceleration, $a$

The acceleration of the bob at a displacement of  $x$  is given by the equation:  $a = -(2\pi f)^2 x$

As discussed before the acceleration acts in the opposite direction to the displacement.

The maximum acceleration occurs at the ends of the swing (1, 3 and 5) when the displacement is equal to the amplitude ( $x = A$ ).

Unit 5	Mr Shepherd <b>SHM Graphs</b>	
Learning Outcomes	To be able to sketch the graphs of displacement, velocity and acceleration for a simple pendulum	
	To be able to know what the gradients represent	
	To be able to explain the energy in a full cycle and sketch the graph	

## Pendulum

Consider the simple pendulum drawn below. When released from A the bob accelerates and moves to the centre point. When it reached B it has reached a maximum velocity in the positive direction and then begins to slow down. At C it has stopped completely so the velocity is zero, it is at a maximum displacement in the positive and accelerates in the negative direction. At D it is back to the centre point and moves at maximum velocity in the negative direction. By E the velocity has dropped to zero, maximum negative displacement and a massive acceleration as it changes direction.

This repeats as the pendulum swings through F, G, H and back to I.

Below are the graphs that represent this:

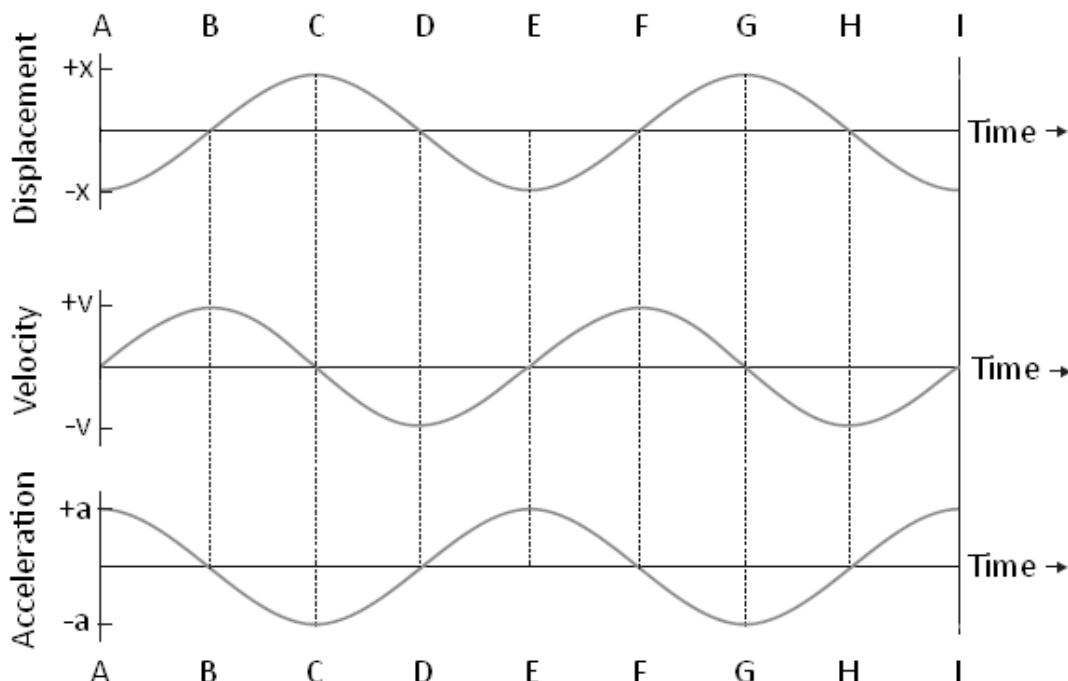
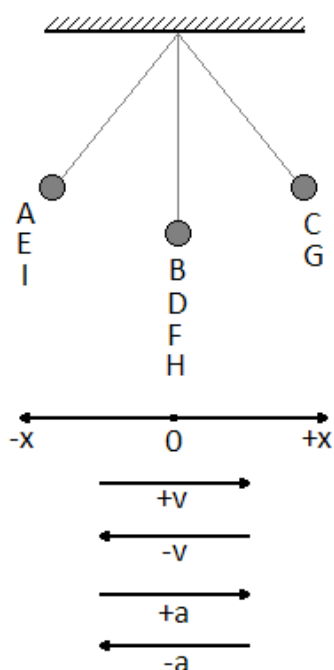

## Gradients

Since  $v = \frac{\Delta s}{\Delta t}$  the gradient of the displacement graph gives us velocity. At C the gradient is zero and we can see that the velocity is zero.

Also since  $a = \frac{\Delta v}{\Delta t}$  the gradient of the velocity graph gives us acceleration. At C the gradient is a maximum in the negative direction and we can see that the acceleration is a maximum in the negative direction.

## Energy

In all simple harmonic motion systems there is a conversion between kinetic energy and potential energy. The total energy of the system remains constant. (This is only true for isolated systems)

For a simple pendulum there is a transformation between kinetic energy and gravitational potential energy.

At its lowest point it has minimum gravitational and maximum kinetic, at its highest point (when displacement is a maximum) it has no kinetic but a maximum gravitational. This is shown in the graph.

For a mass on a spring there is a transformation between kinetic energy, gravitational potential energy and the energy stored in the spring (elastic potential). At the top there is maximum elastic and gravitational but minimum kinetic. In the middle there is maximum kinetic, minimum elastic but it still has some gravitational. At its lowest point it has no kinetic, minimum gravitational but maximum elastic.

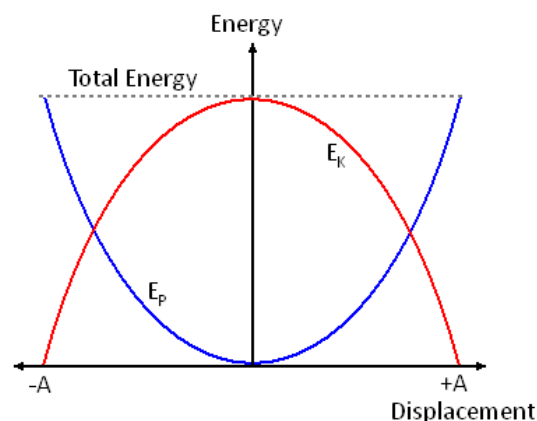

Unit 5	Mr Shepherd <b>SHM Time Periods</b>	
Learning Outcomes	To be able to calculate the time period of a simple pendulum	
	To be able to calculate the time period of a mass on a spring	
	To be able to describe the experiment to find g	

### The Simple Pendulum

In the diagram we can see that the restoring force of the pendulum is:

When  $\theta$  is less than  $10^\circ$  (in radians)  $\sin \theta \approx \theta = \frac{x}{l}$  so the equation can become:

Since both  $F = ma$  and  $a = -(2\pi f)^2 x$  (for SHM) the equation now becomes:

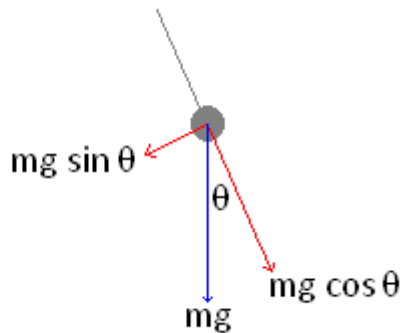
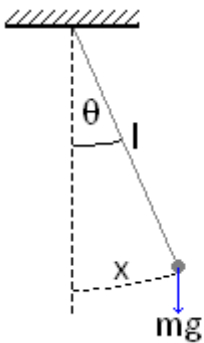

This simplifies to:

Rearranging for  $f$  gives us

And since  $f = \frac{1}{T}$  then:

$$F = -mg \sin \theta$$

$$F = -mg \frac{x}{l}$$

$$-mg \frac{x}{l} = -m(2\pi f)^2 x$$

$$\frac{g}{l} = (2\pi f)^2$$

$$f = \frac{1}{2\pi} \sqrt{\frac{g}{l}}$$

$$T = 2\pi \sqrt{\frac{l}{g}}$$

Time is measured in seconds, s

### Mass on a Spring

When a spring with spring constant  $k$  and length  $l$  has a mass  $m$  attached to the bottom it extends by an extension  $e$ , this is called the static extension and is the new equilibrium point. The tension in the spring is balanced by the weight. We can represent this as:

If the mass is pulled down by a displacement  $x$  and released it will undergo SHM.

The net upwards force will be:

This can be multiplied out to become:

Since  $ke = mg$  this can become:

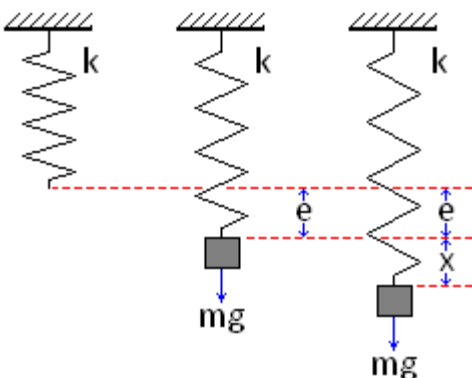

It simplify to:

Since both  $F = ma$  and  $a = -(2\pi f)^2 x$  (for SHM) the equation now becomes:

This simplifies to:

Rearranging for  $f$  gives us:

And since  $f = \frac{1}{T}$  the equation becomes:

$$T = ke = mg$$

$$F = -(k(e+x) - mg)$$

$$F = -(ke + kx - mg)$$

$$F = -(mg + kx - mg)$$

$$F = -kx$$

$$-kx = -m(2\pi f)^2 x$$

$$\frac{k}{m} = (2\pi f)^2$$

$$f = \frac{1}{2\pi} \sqrt{\frac{k}{m}}$$

$$T = 2\pi \sqrt{\frac{m}{k}}$$

Time is measured in seconds, s

### Finding g

We can find the value of the gravitational field strength,  $g$ , on Earth by carrying out the following experiment. Set up a simple pendulum of length  $l$  and measure the time for one oscillation.

If we measure the time taken for 20 oscillations and divide it by 20 we reduce the percentage human error of the reading and make our experiment more accurate.

If we look at the equation  $T = 2\pi \sqrt{\frac{l}{g}}$  and rearrange it to become:  $T^2 = \frac{4\pi^2}{g} l$ , by plotting a graph of  $T^2$

against  $l$  we can find the value of  $g$  from the gradient which will be  $\frac{4\pi^2}{g}$



Unit 5	Mr Shepherd	
	<h1>Resonance and Damping</h1>	
Learning Outcomes	To know what free and forced vibration are and the phase difference between the driver and driven	
	To know what resonance is and how it is reached	
	To know what light, heavy and critical damping are and their affects on resonance	

## Free Vibration

Free vibration is where a system is given an initial displacement and then allowed to vibrate/oscillate freely. The system will oscillate at a set frequency called the natural frequency,  $f_0$ . We have seen from the last lesson that the time period for a pendulum only depends on the length and gravitational field strength whilst the time period of a mass and spring only depends on the mass and the spring constant. These factors govern the natural frequency of a system.

## Forced Vibration

Forced vibration is where a driving force is continuously applied to make the system vibrate/oscillate. The thing that provides the driving force will be moving at a certain frequency. We call this the driving frequency.

## Resonance

If I hold one end of a slinky and let the other oscillate freely we have a free vibration system. If I move my hand up and down I force the slinky to vibrate. The frequency of my hand is the driving frequency.

When the driving frequency is lower than the natural frequency the oscillations have a low amplitude

When the driving frequency is the same as the natural frequency the amplitude increases massively, maybe even exponentially.

When the driving frequency is higher than the natural frequency the amplitude of the oscillations decreases again.

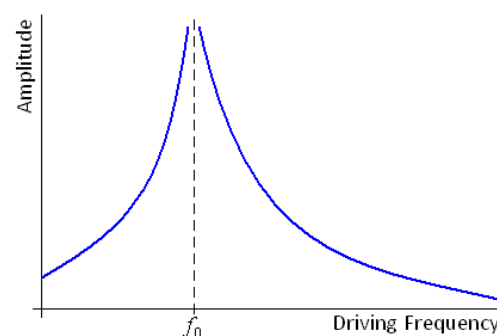

## Phase Difference between driver and driven

When the driving force begins to oscillate the driven object the phase difference is 0.

When resonance is achieved the phase difference between them is  $\pi$ .

When the driving frequency increases beyond the natural frequency the phase difference increases to  $\pi/2$ .

## Damping

Damping forces oppose the motion of the oscillating body, they slow or stop simple harmonic motion from occurring.

*Damping forces act in the opposite direction to the velocity.*

Galileo made an important observation while watching lamps swing in Pisa cathedral. He noticed that the swinging gradually died away but the time taken for each swing stayed roughly the same. The swing of the lamp was being damped by air resistance.

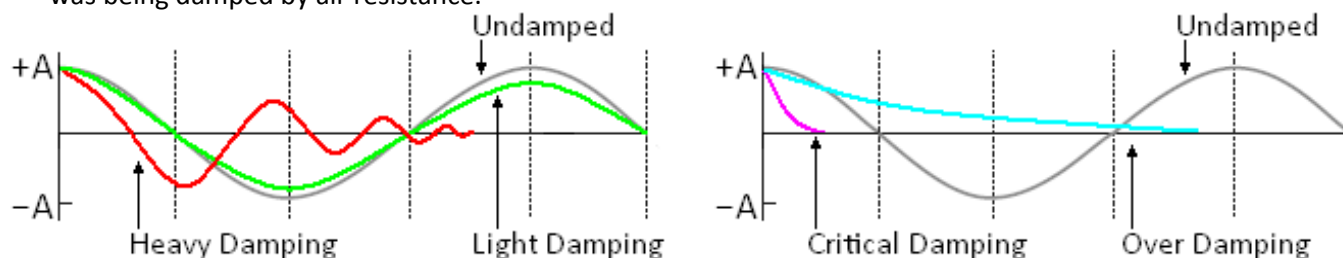

**Light damping** slowly reduces the amplitude of the oscillations, but keeps the time period almost constant.

**Heavy damping** allows the body to oscillate but brings it quickly to rest.

**Critical damping** brings the body back to the equilibrium point very quickly with out oscillation.

**Over damping** also prevent oscillation but makes the body take a longer time to reach equilibrium.

## Damping and Resonance

Damping reduces the size of the oscillations at resonance. There is still a maximum amplitude reached but it is much lower than when the system is undamped. We say that damping reduces the sharpness of resonance. This becomes clearer if we look at the graph on the right. It shows the amplitude of oscillation against frequency for different levels of damping.

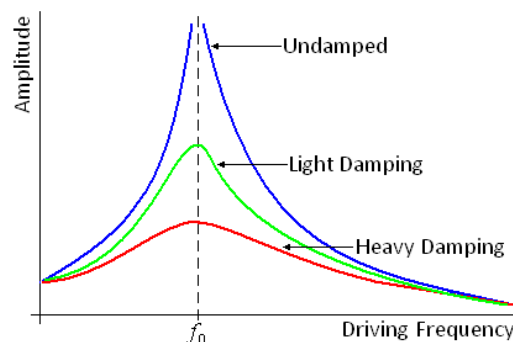

Unit 5	Mr Shepherd		<h1>Gravitational Fields</h1>	
Learning Outcomes	To be able to calculate the force of gravity between two masses			
	To be able to explain what gravitational field strength is			
	To be able to calculate the gravitational field strength at a distance $r$ from the centre			

### Newton's Law of Gravitation (Gravity) *(Also seen in GCSE Physics 3)*

Gravity is an attractive force that acts between all masses. It is the masses themselves that cause the force to exist. The force that acts between two masses,  $m_1$  and  $m_2$ , whose centres are separated by a distance of  $r$  is given by:

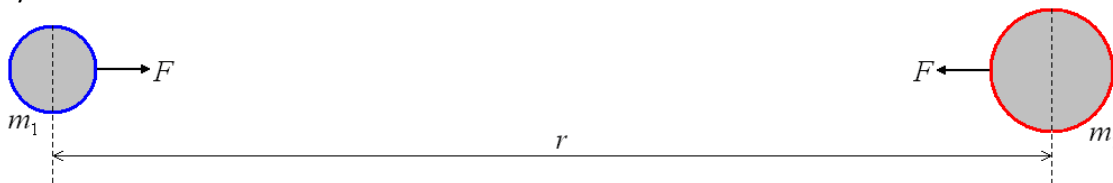

$$F \propto \frac{m_1 m_2}{r^2}$$

This was tested experimentally in a lab using large lead spheres and was refined to become:

$$F = -\frac{Gm_1 m_2}{r^2}$$

**G is the Gravitational Constant,  $G = 6.67 \times 10^{-11} \text{ N m}^2 \text{ kg}^{-2}$**

When one of the masses is of planetary size,  $M$ , the force between it and a test mass,  $m$ , whose centres are separated by a distance of  $r$  is given by:

$$F = -\frac{GMm}{r^2}$$

The minus sign means that the force is attractive, the force is in the opposite direction to the distance from the mass (displacement). This will become clearer when we look at the electric force.

Negative = Attractive

Positive = Repulsive

**Force is measured in Newtons, N**

### Gravitational Fields

A gravitational field is the area around a mass where any other mass will experience a force. We can model a field with field lines or lines of force.

#### Radial Fields

The field lines end at the centre of a mass and tail back to infinity. We can see that they become more spread out the further from the mass we go.



#### Uniform Fields

The field lines are parallel in a uniform field. At the surface of the Earth we can assume the field lines are parallel, even though they are not.

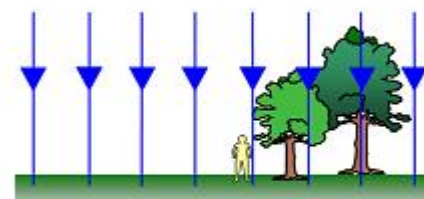

### Gravitational Field Strength, $g$

We can think of gravitational field strength as the concentration of the field lines at that point. We can see from the diagrams above that the field strength is constant in a uniform field but drops quickly as we move further out in a radial field.

The gravitational field strength at a point is a vector quantity and is defined as:

*The force per unit mass acting on a small mass placed at that point in the field.*

We can represent this with the equation:

$$g = \frac{F}{m}$$

If we use our equation for the gravitational force at a distance  $r$  and substitute this in for  $F$  we get:

$g = -\frac{GMm}{r^2 m}$  which simplifies to:

$$g = -\frac{GM}{r^2}$$

Unit 5	Mr Shepherd	
	<h1>Gravitational Potential</h1>	
Learning Outcomes	To be able to explain what gravitational potential is and be able to calculate it	
	To know how gravitational potential is linked to potential energy and be able to calculate it	
	To be able to sketch graphs of potential and field strength over distance from surface	

## Gravitational Potential, $V$

The gravitational potential at a point  $r$  from a planet or mass is defined as:

*The work done per unit mass against the field to move a point mass from infinity to that point*



The gravitational potential at a distance  $r$  from a mass  $M$  is given by:

$$V = -\frac{GM}{r}$$

The value is negative because the potential at infinity is zero and as we move to the mass we lose potential or energy. Gravitational potential is a scalar quantity.

The gravitational field is attractive so work is done **by** the field in moving the mass, meaning energy is given out.

**Gravitational Potential is measured in Joules per kilogram,  $\text{J kg}^{-1}$**

## Gravitational Potential Energy (Also seen in AS Unit 2)

In Unit 2 we calculated the gravitational potential energy of an object of mass  $m$  at a height of  $h$  with:

$$E_p = mgh$$

This is only true when the gravitational field strength does not change (or is constant) such as in a uniform field.

For radial fields the gravitational field strength is given by  $g = -\frac{GM}{r^2}$

We can use this to help us calculate the gravitational potential energy in a radial field at a height  $r$ .

$$E_p = mgh \quad \rightarrow \quad E_p = m \frac{GM}{r^2} r \quad \rightarrow \quad E_p = m \frac{GM}{r}$$

*(We have dropped the negative sign because energy is a scalar quantity)*

If we look at the top equation for gravitational potential we can see that the gravitational potential energy can be calculated using:

$$E_p = mV$$

The work done to move an object from potential  $V_1$  to potential  $V_2$  is given by:

$\Delta W = m(V_2 - V_1)$  which can be written as  $\Delta W = m\Delta V$

**Gravitational Potential Energy is measured in Joules, J**

## Graphs

Here are the graphs of how gravitational field strength and gravitational potential vary with distance from the centre of a mass (eg planet). In both cases  $R$  is the radius of the mass (planet).

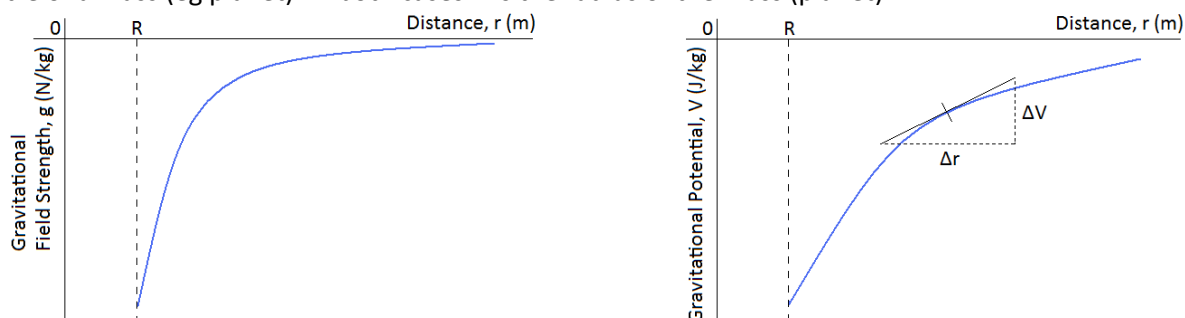

The gradient of the gravitational potential graph gives us the gravitational field strength at that point. To find the gradient at a point on a curve we must draw a tangent to the line then calculate the gradient of the tangent:

$$\text{gradient} = \frac{\Delta y}{\Delta x} \quad \rightarrow \quad g = \frac{\Delta V}{\Delta r}$$

If we rearrange the equation we can see where we get the top equation for gravitational potential.

$$g = \frac{\Delta V}{\Delta r} \quad \rightarrow \quad g\Delta r = \Delta V \quad \text{sub in the equation for } g \quad \rightarrow \quad -\frac{GM}{r^2}\Delta r = \Delta V \quad \rightarrow \quad -\frac{GM}{r^2}r = V \quad \rightarrow \quad -\frac{GM}{r} = V$$

Unit 5	Mr Shepherd	
	<h1>Orbits and Escape Velocity</h1>	
Learning Outcomes	To be able to calculate the orbital speed of a satellite if given the height from the Earth	
	To be able to calculate the time of orbit of a satellite if given the height from the Earth	
	To be able to calculate the escape velocity from a planet	

### Orbits (Also seen in GCSE Physics 3)

For anything to stay in orbit it requires two things:

- \*A centripetal force, caused by the gravitational force acting between the object orbiting and the object being orbited
- \*To be moving at a high speed

We now know equations for calculating the centripetal force of an object moving in a circle of radius  $r$  AND for calculating the gravitational force between two masses separated by a distance of  $r$ .

Centripetal force at distance  $r$ :  $F = mv\omega$     or     $F = mr\omega^2$     or     $F = \frac{mv^2}{r}$

Gravitational force at distance  $r$ :  $F = \frac{GMm}{r^2}$

These forces are equal to each other, since it is the force of gravity causing the centripetal force.

From these we can calculate many things about an orbiting object:

#### The speed needed for a given radius

$$\frac{mv^2}{r} = \frac{GMm}{r^2} \quad \rightarrow \quad \frac{v^2}{r} = \frac{GM}{r^2} \quad \rightarrow \quad v^2 = \frac{GM}{r} \quad \rightarrow \quad \boxed{v = \sqrt{\frac{GM}{r}}}$$

#### The time of orbit for a given radius

$$mr\omega^2 = \frac{GMm}{r^2} \quad \rightarrow \quad \omega^2 = \frac{GM}{r^3} \quad \rightarrow \quad (2\pi f)^2 = \frac{GM}{r^3} \quad \rightarrow \quad \left(\frac{2\pi}{T}\right)^2 = \frac{GM}{r^3}$$

$$\rightarrow \quad \frac{4\pi^2}{T^2} = \frac{GM}{r^3} \quad \rightarrow \quad \frac{T^2}{4\pi^2} = \frac{r^3}{GM} \quad \rightarrow \quad T^2 = \frac{4\pi^2 r^3}{GM} \quad \rightarrow \quad \boxed{T = \sqrt{\frac{4\pi^2 r^3}{GM}}}$$

### Energy of Orbit

The total energy of a body in orbit is given by the equation:

Total energy = Kinetic energy + Potential energy    or     $E_T = E_K + E_P$

$$E_T = \frac{1}{2}mv^2 - \frac{GMm}{r} \quad \rightarrow \quad E_T = \frac{1}{2}m\left(\sqrt{\frac{GM}{r}}\right)^2 - \frac{GMm}{r} \quad \rightarrow \quad E_T = \frac{1}{2}\frac{GMm}{r} - \frac{GMm}{r} \quad \rightarrow \quad \boxed{E_T = -\frac{1}{2}\frac{GMm}{r}}$$

### Geostationary Orbits (Also seen in GCSE Physics 3)

Geostationary orbiting satellites orbit around the equator from West to East. They stay above the same point on the equator meaning that the time period is 24 hours or seconds. They are used for communication satellites such as television or mobile phone signals.

### Escape Velocity

For an object to be thrown from the surface of a planet and escape the gravitational field (to infinity) the initial kinetic energy it has at the surface must be equal to the potential energy (work done) to take it from the surface to infinity.

Potential energy:  $E_P = m\frac{GM}{R}$     Kinetic energy:  $E_K = \frac{1}{2}mv^2$

$$\frac{1}{2}mv^2 = m\frac{GM}{R} \quad \rightarrow \quad \frac{1}{2}v^2 = \frac{GM}{R} \quad \rightarrow \quad v^2 = \frac{2GM}{R} \quad \rightarrow \quad \boxed{v = \sqrt{\frac{2GM}{R}}}$$

For an object to be escape the Earth.....

$$v = \sqrt{\frac{2GM}{R}} \quad v = \sqrt{\frac{2(6.67 \times 10^{-11})(6.00 \times 10^{24})}{(6.40 \times 10^6)}} \quad v = 11183 \text{ m/s}$$

This calculation is unrealistic. It assumes that all the kinetic energy must be provided instantaneously.

We have multistage rockets that provide a continuous thrust



Unit 6	Mr Shepherd <b>Electric Fields</b>	
Learning Outcomes	To be able to calculate the force of gravity between two charges	
	To be able to explain what electric field strength is	
	To be able to calculate the electric field strength at a distance $r$ from the centre	

### Coulomb's Law (Electric Force) (Also seen in GCSE Physics 2)

The electrostatic force acts between all charged particles and can be attractive or repulsive. It is the charges themselves that cause the force to exist. The force that acts between two charges,  $Q_1$  and  $Q_2$ , whose centres are separated by a distance of  $r$  is given by:

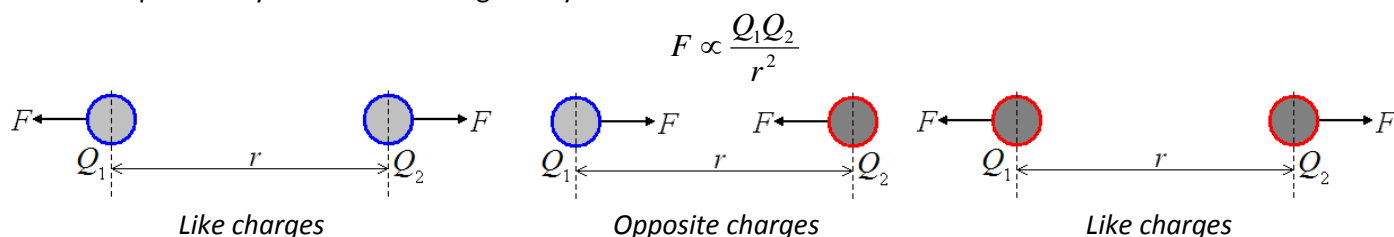

The proportional constant was found and the equation becomes:

$$F = \frac{1}{4\pi\epsilon_0} \frac{Q_1 Q_2}{r^2}$$

$\epsilon_0$  is the Permittivity of Free Space,  $\epsilon_0 = 8.854 \times 10^{-12} \text{ F m}^{-1}$

When one of the charges is large,  $Q$ , the force between it and a test charge,  $q$ , whose centres are separated by a distance of  $r$  is given by:

$$F = \frac{Qq}{4\pi\epsilon_0 r^2}$$

If the two charges are positive,

$$(+Q)(+q) = +Qq$$

A positive force means the charges repel.

If the two charges are negative,

$$(-Q)(-q) = +Qq$$

A positive force means the charges repel.

If one is negative and one is positive,

$$(-Q)(+q) = -Qq$$

A negative force means the charges attract.

### Electric Fields

An electric field is the area around a charge where any other charge will experience a force. We can model a field with field lines or lines of force.

#### Radial Fields

For a positive charge the field lines start at the charge and go out to infinity. For a negative charge the field lines end at the centre of a mass and tail back from infinity. We can see that they become more spread out the further from the charge we go.

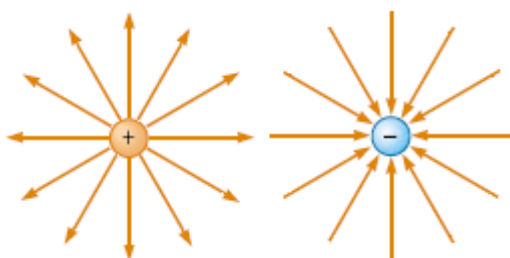

#### Uniform Fields

The field lines are parallel in a uniform field. Between two conducting plates the field lines leave the positive plate and enter the negative plate.

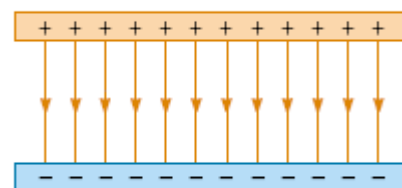

### Electric Field Strength, $E$

We can think of electric field strength as the concentration of the field lines at that point. We can see from the diagrams above that the field strength is constant in a uniform field but drops quickly as we move further out in a radial field.

The electric field strength at a point is a vector quantity and is defined as:

*The force per unit charge acting on a small charge placed at that point in the field*

We can represent this with the equation:

$$E = \frac{F}{q}$$

If we use our equation for the electric force at a distance  $r$  and substitute this in for  $F$  we get:

$$E = \frac{Qq}{4\pi\epsilon_0 r^2 q} \text{ which simplifies to:}$$

$$E = \frac{Q}{4\pi\epsilon_0 r^2}$$

**(RADIAL FIELDS)**

**Electric Field Strength is measured in Newtons per Coulomb,  $\text{N C}^{-1}$**

Unit 6	Mr Shepherd <b>Electric Potential</b>	
Learning Outcomes	To be able to explain what electric potential is and be able to calculate it	
	To know what the field strength is like in a uniform field and how it is linked to electric potential	
	To be able to sketch graphs of potential and field strength over distance from surface	

## Electric Potential, $V$

The electric potential at a point  $r$  from a point charge is defined as:

*The work done per unit charge against the field to move a positive point charge from infinity to that point*



The electric potential at a distance  $r$  from a charge  $Q$  is given by:

$$V = \frac{Q}{4\pi\epsilon_0 r}$$

The value will be positive when work is done against the field (when like charges are repelling).

The value will be negative when work is done by the field (when opposite charges attract).

In both cases the potential at infinity is zero. Electric potential is a scalar quantity.

**Electric Potential is measured in Joules per Coulomb,  $J C^{-1}$**

## Electric Potential Difference (Also seen in GCSE Physics 2 and AS Unit 1)

Electric potential is the work done per unit charge which can be written like this:

$$V = \frac{W}{Q}$$

We came across this equation in the QVIRt lesson of Unit 1. We used it to define the potential difference as the energy given to each charge. From what we have just defined we can now update our definition of potential difference. *Potential difference is the difference in electric potential between two points in an electric field.*

The work done to move a charge from potential  $V_1$  to potential  $V_2$  is given by:

$$\Delta W = Q(V_2 - V_1) \text{ which can be written as } \Delta W = Q\Delta V$$

## Uniform Fields

In a uniform field like that between two conducting plates the field strength is constant as we have already seen. Now that we understand electric potential we can use an equation for the field strength in a uniform field.

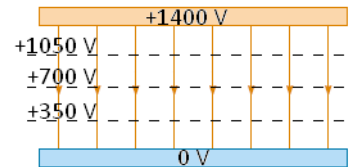

$$E = \frac{V}{d} \text{ Where } V \text{ is the potential difference between the plates and } d \text{ is the separation of the plates.}$$

**Electric Field Strength can be measured in Volts per metre,  $V m^{-1}$**

## Graphs

Here are the graphs of how electric field strength and electric potential vary with distance from the centre of a charged sphere. In both cases  $R$  is the radius of the sphere.

The gradient of the electric potential graph gives us the electric field strength at that point. To find the gradient at a point on a curve we must draw a tangent to the line then calculate the gradient of the tangent:

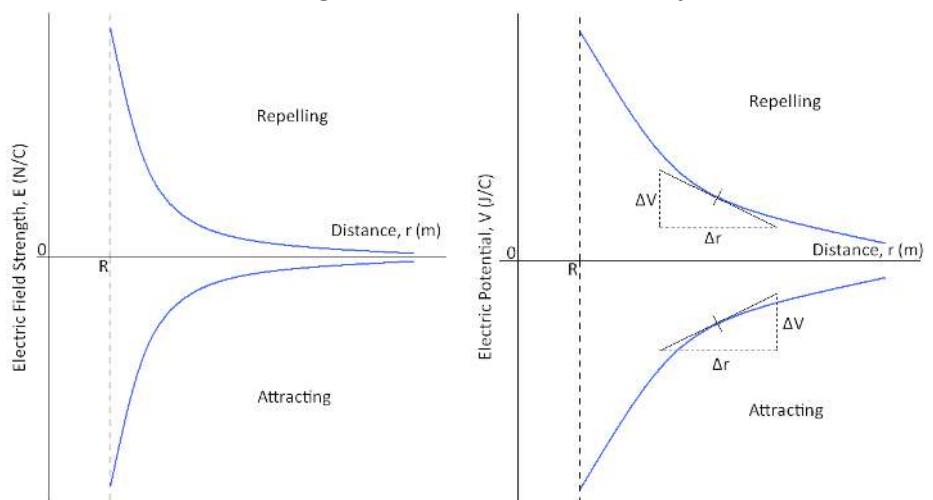

$$\text{gradient} = \frac{\Delta y}{\Delta x} \rightarrow E = \frac{\Delta V}{\Delta r}$$

If we rearrange the equation we can see where we get the top equation for electric potential.

$$E = \frac{\Delta V}{\Delta r} \rightarrow E\Delta r = \Delta V \text{ sub in the equation for } E \rightarrow \frac{Q}{4\pi\epsilon_0 r^2} \Delta r = \Delta V \rightarrow \frac{Q}{4\pi\epsilon_0 r^2} r = V \rightarrow \frac{Q}{4\pi\epsilon_0 r} = V$$

Unit 6	Mr Shepherd <b>Fields Comparison</b>	
Learning Outcomes	To be able to describe and explain the motion of a charged particle in an electric field	
	To be able to state the similarities between gravitational and electric fields	
	To be able to state the differences between gravitational and electric fields	

### Motion in an Electric Field

A charged particle moving through an electric field will feel a force towards the oppositely charged plate.

We see that the electron moves in a parabola towards the positive plate and the positron moves towards the negative plate.

The field strength is constant so the force is the same at all points in the field and is given by  $F = qE$ . The direction of the force depends on the charge of the particle entering the field

Like the projectiles we looked at during AS Unit 2, the vertical velocity is independent from the horizontal velocity.

The acceleration in the vertical plane will be equal to  $E$  and it will 'freefall' like a mass in a gravitational field.

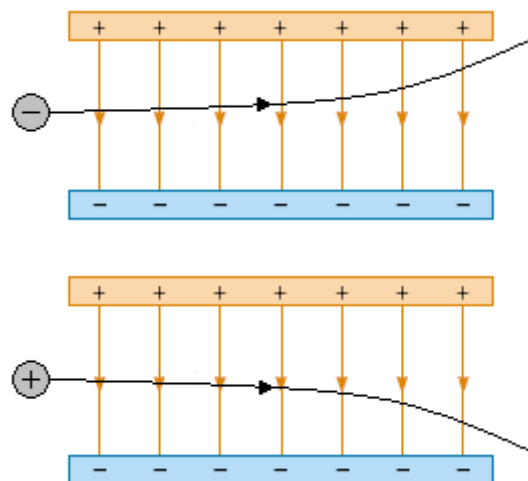

### Comparing Fields

We have seen that the characteristics of gravitational and electric fields have some similarities and differences.

	<b>Gravitational Fields</b>	<b>Electric Fields</b>
<i>Force is between</i>	Masses	Charges
<i>Constant of proportionality</i>	$G$	$\frac{1}{4\pi\epsilon_0}$
<i>Equation for force</i>	$F = -\frac{Gm_1m_2}{r^2}$ Newton (N) Vector	$F = \frac{1}{4\pi\epsilon_0} \frac{Q_1Q_2}{r^2}$ Newtons (N) Vector
<i>Nature of force</i>	Attractive only	Like charges repel Different charges attract
<i>Definition of field strength</i>	Force per unit mass	Force per unit charge
<i>Field strength in radial field</i>	$g = -\frac{GM}{r^2}$ Newtons per kilogram (N/kg) Vector	$E = \frac{Q}{4\pi\epsilon_0 r^2}$ Newtons per Coulomb (N/C) Vector
<i>Definition of potential</i>	The work done in bringing a unit mass from infinity to the point in the field	The work done in bringing a unit charge from infinity to the point in the field
<i>Potential</i>	$V = -\frac{GM}{r}$ Joules per kilogram (J/kg) Scalar	$V = \frac{Q}{4\pi\epsilon_0 r}$ Joules per Coulomb (J/C) Scalar
<i>Potential at infinity</i>	0	0
<i>Work done moving between points of different potential</i>	$\Delta W = m\Delta V$ Joules (J) Scalar	$\Delta W = Q\Delta V$ Joules (J) Scalar
<i>Gradient of potential against distance graph</i>	Field strength	Field strength

Unit 6	Mr Shepherd	
	<h1>Capacitors</h1>	
Learning Outcomes	To be able to calculate capacitance	
	To be able to explain what happens as a capacitor charges up	
	To be able to derive the energy stored by a capacitor	

## Capacitors

A capacitor is an electronic component that can store electrical charge and then release it.

It is made of two conducting plates separated by an insulator.

The charge that is stored by the capacitor is due to the potential difference across. We can write this as:

$$Q \propto V \quad \text{or} \quad Q = kV$$

$k$  is a constant specific to the capacitor, this is called the capacitance and is represented by the symbol  $C$

$$Q = CV$$

Capacitance is measured in Farads, F

Charge is measured in Coulombs, C

We can rearrange the equation into  $C = Q / V$  and from this we can see that capacitance is a measure of the charge stored per volt of potential difference. 1 Farad means 1 Coulomb of charge is stored per Volt.



## Water Analogy

We can think of the charge stored by a capacitor as the volume of water in a bucket.

The cross-sectional area of the bucket represents the capacitance of the capacitor. We can see that the capacitance of capacitor 1 is higher than the capacitance of capacitor 2.

The height of the water represents the potential difference across the capacitor.

We can see that the potential difference across capacitor 2 is higher than the p.d. across capacitor 1. The charge stored by both capacitors is the same.

A capacitor with a lower capacitance can store more charge if the p.d. across it is increased.

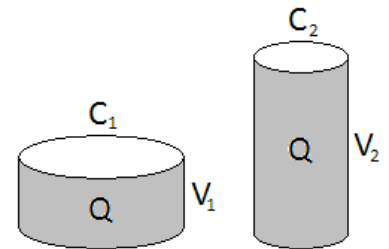

## Charging and Discharging

When a capacitor is connected to a battery it sends out electrons to one of the plates, this becomes negatively charged. The same amount of electrons move from the second plate and enter the battery, leaving the plate positively charged. The capacitor is now storing a charge or is 'charged'.

If the charged capacitor is disconnected from the battery and connected to a lamp it will give out the stored charge or will 'discharge'. The electrons on the negative plate move through the circuit and onto the positive plate. The plates now have no charge on them. The energy stored by the capacitor is transferred to the bulb whilst the electrons move (whilst a current flows).

## Energy Stored by a Capacitor

The top equation shows us that the charge of a capacitor increases with the potential difference across it. If we plotted p.d. against charge we get a graph that looks like this →

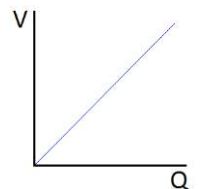

We can derive an equation to find the energy that a capacitor stores by considering the energy transferred during the shaded section on the lower graph.

In this section the charge changes from  $q$  to  $q + \Delta q$  when an average p.d. of  $v$  is applied across it.

Using  $E = VQ$  (see AS Unit 1) the energy stored is  $E = v \Delta q$ .

The total energy is equal to the total of all the little rectangular sections and is given by  $E = \frac{1}{2} QV$ . This is also equal to the area under the graph.

We can use the top equation to derive two more equations for the energy stored by a capacitor:

$$E = \frac{1}{2} QV$$

$$E = \frac{1}{2} CV^2$$

$$E = \frac{1}{2} \frac{Q^2}{C}$$

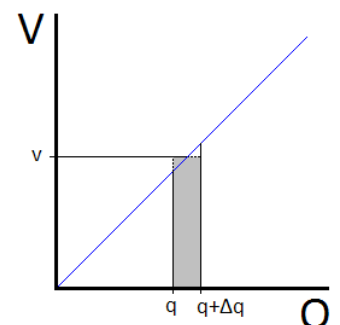



Unit 6	Mr Shepherd	
	<h1>Charging and Discharging</h1>	
Learning Outcomes	To be able to sketch graphs of charge, p.d. and current over time for a charging capacitor	
	To be able to sketch graphs of charge, p.d. and current over time for a discharging capacitor	
	To be able to calculate the time constant and state its significance	

In the diagram to the right a capacitor can be charged by the battery if the switch is moved to position A. It can then be discharged through a resistor by moving the switch to position B.

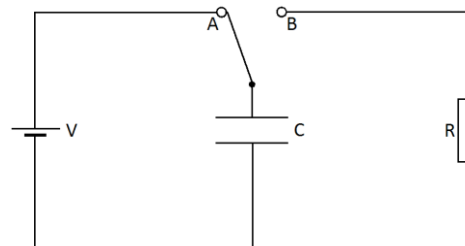

### Charging a Capacitor

When the switch is moved to A the battery sends electrons to the lower plate and takes them from the upper plate. This leaves the lower plate negatively charged and the upper plate positively charged. An electric field is set up between the plates.

**Current** The current is the flow of electrons through the circuit (see Unit 1). There is a large current initially as electrons move to the lower plate. As time passes and more electrons are on the plate it becomes more difficult to add more due to the electrostatic repulsion of similar charges. When no more electrons move in the circuit the current drops to zero.

**Charge** The charge stored by the capacitor increases with every electron that moves to the negative plate. The amount of charge increases quickly at the beginning because a large current is flowing. As the current drops the rate at which the charge increases also drops. A maximum charge is reached.

**P.D.** Since potential difference is proportional to charge, as charge builds up so does p.d. The maximum value of p.d. is reached as is equal to the terminal p.d. of the battery.

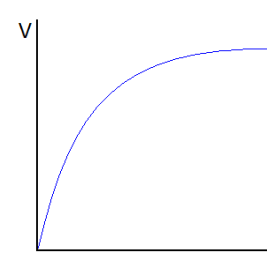
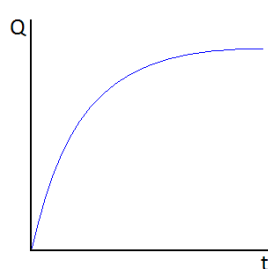
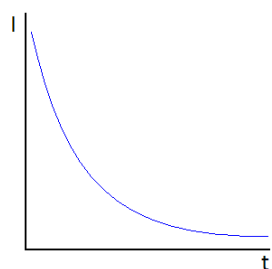

### Discharging a Capacitor

When the switch is moved to B the electrons on the negative plate repel each other and move back into the circuit. Eventually both plates lose their charge and the electric field between them disappears.

**Current** There is initially a large current as the electrons leave the negative plate. As the number of electrons on the negative plate falls so does the size of the repulsive electrostatic force, this makes the current fall at a slower rate. When no more electrons move in the circuit the current drops to zero.

**Charge** The charge that was stored on the plates now falls with every electron that leaves the negative plate. The charge falls quickly initially and then slows, eventually reaching zero when all the charge has left the plates.

**P.D.** As the charge falls to zero so does the potential difference across the capacitor.

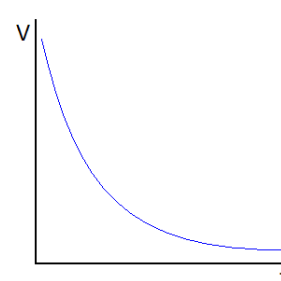
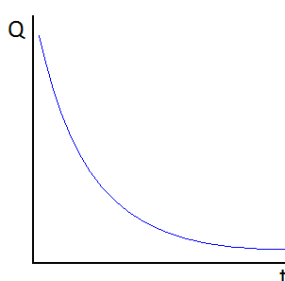
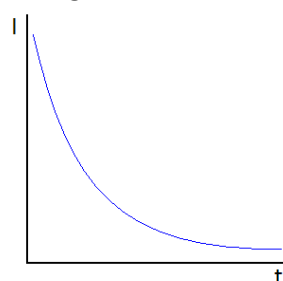

### Time Constant, $\tau$

The time it takes for the capacitor to discharge depends on the 'time constant'.

The time constant is the time it takes for the charge or p.d. of a capacitor to fall to **37%** of the initial value. OR

The time constant is the time it takes for the charge or p.d. of a capacitor to fall by **63%** of the initial value.

It is given by the equation:

$$\tau = RC$$

If the capacitor has a larger capacitance it means it can hold more charge, this means it will take longer to discharge. If the resistor has a larger resistance it means it is harder to move the electrons around the circuit, this also means it will take longer to discharge.

Unit 6	Mr Shepherd	
	<h1>Exponential Decay</h1>	
Learning Outcomes	To be able to calculate the charge of a discharging capacitor after a time, $t$	
	To be able to calculate the potential difference across a discharging capacitor after a time, $t$	
	To be able to calculate the current through a discharging capacitor after a time, $t$	

### Finding $\tau$ from Graphs

The time constant of a discharging capacitor can be found from a graph of either charge, current or potential difference against time. After one time constant the value will have dropped to 0.37 of the initial value.

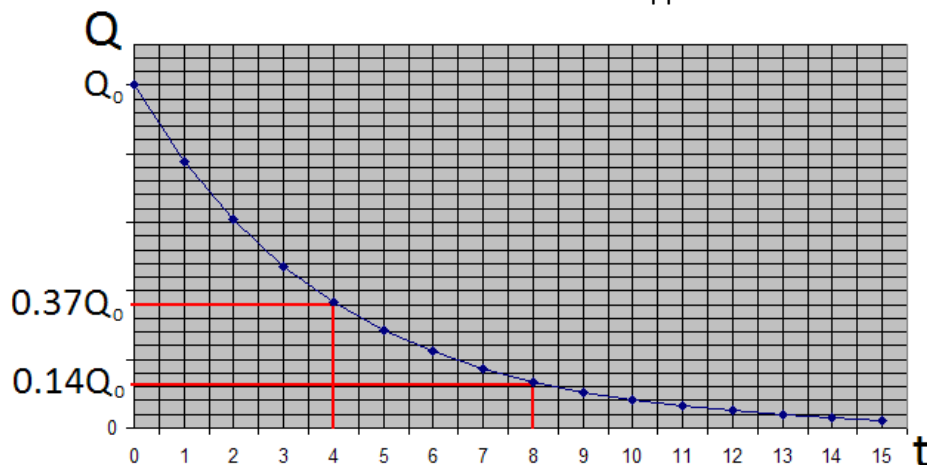

In this case the time constant is 4 seconds.

### Quantitative Treatment

We could use the graph above to find the charge on the capacitor after a time,  $t$ . We could also use it to find the time it takes for the charge to fall to a value of  $Q$ .

This requires the graph to be drawn very accurately and values need to be taken from it very carefully. Instead of doing this we can use the following equation to calculate the charge,  $Q$  after a time,  $t$ .

$$Q = Q_0 e^{-t/RC}$$

$t$  is the time that has elapsed since discharge began

$Q$  is the remaining charge

$Q_0$  is the initial (or starting) charge

$RC$  is the time constant, also equal to the resistance multiplied by the capacitance.

**Time is measured in seconds, s**

When the time elapsed is equal to the time constant the charge should have fallen to 37% of the initial value.

$$Q = Q_0 e^{-t/RC} \rightarrow Q = Q_0 e^{-RC/RC} \rightarrow Q = Q_0 e^{-1} \text{ (but } e^{-1} = 0.37) \rightarrow Q = Q_0 0.37$$

When the time elapsed is equal to twice the time constant the charge should have fallen to 37% of 37% of the initial value.

$$Q = Q_0 e^{-t/RC} \rightarrow Q = Q_0 e^{-2RC/RC} \rightarrow Q = Q_0 e^{-2} \text{ (but } e^{-2} = 0.37 \times 0.37) \rightarrow Q = Q_0 0.14$$

Similar equations can be established for the current flowing through and the potential difference across the capacitor after time,  $t$ :

$$Q = Q_0 e^{-t/RC}$$

$$I = I_0 e^{-t/RC}$$

$$V = V_0 e^{-t/RC}$$

### Rearranging

The equations above can be rearranged to make  $t$  the subject. We will use the equation for charge:

$$Q = Q_0 e^{-t/RC} \rightarrow \frac{Q}{Q_0} = e^{-t/RC} \rightarrow \ln\left(\frac{Q}{Q_0}\right) = -t/RC \rightarrow \ln\left(\frac{Q}{Q_0}\right)RC = -t \rightarrow -\ln\left(\frac{Q}{Q_0}\right)RC = t$$

They can also be rearranged to make  $RC$  (time constant) the subject:

$$Q = Q_0 e^{-t/RC} \rightarrow \frac{Q}{Q_0} = e^{-t/RC} \rightarrow \ln\left(\frac{Q}{Q_0}\right) = -t/RC \rightarrow RC = \frac{-t}{\ln\left(\frac{Q}{Q_0}\right)}$$

Unit 6	Mr Shepherd	
	<h1>Force on a Current Carrying Wire</h1>	
Learning Outcomes	To be able to explain why a wire with a current flowing through it will experience a force	
	To be able to calculate the size of the force on the wire	
	To be able to state the direction of the force on the wire	

We will be looking at the force a current carrying wire experiences when it is in a magnetic field. Before we look into the size and direction of the force we need to establish some basics.

### Conventional Current

We know that the current flowing in a circuit is due to the negative electrons flowing from the negative terminal of a battery to the positive terminal.

*Negative to Positive is the flow of electrons*

Before the discovery of the electron scientist thought that the current flowed from the positive terminal to the negative one. By the time the electron was discovered many laws had been established to explain the world around them using current as flowing from positive to negative.

*Positive to Negative is the Conventional Current*

### Magnetic Field Lines

We are familiar with the shape of a magnetic field around a bar magnet. Magnetic field lines leave the North Pole of the magnet and enter the South Pole. The poles of a magnet are stronger than the side because there are more field lines in the same area of space.

*Magnetic field lines go from North to South*

### A 3D Problem

We will be looking at movement, fields and currents in 3D but our page is only 2D. To solve this problem we will use the following notation: A dot means coming out of the page and a cross means going into the page. Imagine an arrow fired from a bow, pointy end means it's coming towards you, cross means its moving away.

⊙ out of the page, ⊗ into the page

### Current Carrying Wires

When a current flows through a straight piece of wire it creates a circular magnetic field. The Right Hand Grip Rule shows us the direction of the magnetic field. If we use our right hand and do a thumbs up the thumb is the direction of the conventional current and the fingers point the direction of the field lines.

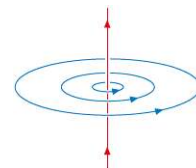

*Right hand thumbs up*

### Force on a Current Carrying Wire

When a wire is placed between a North and South Pole (in a magnetic field), nothing happens.

When a (conventional) current flows through the wire it experiences a force due to the magnetic fields of the magnet and the wire. If we look at the diagram we can see that the magnetic field lines above are more compact than below. This forces the wire downwards.

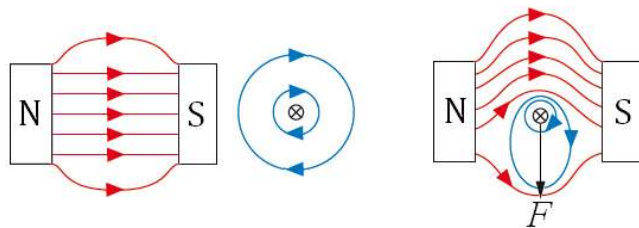

### Fleming's Left Hand Rule

This rule links the directions of the force, magnetic field and conventional current which are all at right angles to each other. Your first finger points from North to South, your middle finger points from positive to negative and your thumb points in the direction of the force.

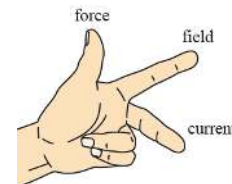

### Size of the Force

The size of the force on a wire of length  $l$ , carrying a current  $I$  placed in a magnetic field of magnetic flux density  $B$  is given by the equation:

$$F = BIl$$

Here the wire is at  $90^\circ$  to the magnetic field lines.

When the wire is at an angle of  $\theta$  with the magnetic field the force is given by:

$$F = BIl \sin \theta$$

If we rearrange the equation to  $B = \frac{F}{Il}$  we see that 1 Tesla is the magnetic flux density (field strength) that

causes a 1 Newton force to act on 1 metre of wire carrying 1 Amp of current.

**Magnetic Flux Density is measured in Tesla, T**

This equation looks very familiar if we compare it to the force in a gravitational and electric field.

$$F = m.g \quad F = q.E \quad F = Il.B$$

Unit 6	Mr Shepherd	
	<h1>Force on a Charged Particle</h1>	
Learning Outcomes	To be able to calculate the size and direction of the force on a charged particle in a magnetic field	
	To be able to describe the motion of a charged particle in a magnetic field	
	To be able to describe the main features of a cyclotron and explain how it works	

## Force on Charged Particle

From our equation for the force a magnetic field will exert on a wire we can derive a equation for the force it will exert on a single charged particle.

Start with  $F = BIl$ . In Unit 1 we defined the current as  $I = \frac{Q}{t}$  so we can sub this in to become  $F = B \frac{Q}{t} l$

We can rewrite this equation  $F = BQ \frac{l}{t}$  and use  $v = \frac{l}{t}$  from Unit 2 to arrive at the equation:  $F = BQv$

## Moving in a Circle

If a charged particle enters a magnetic field it will feel a force. We now know the size of the force (given by equation above) and direction of the force (given by Fleming's Left Hand Rule).

If we use the left hand rule in the diagram to the right we can see that the force is always at right angles to the velocity. First finger points into the page, middle finger points along the line and our thumb points upwards.

While the particle is in the magnetic field it will move in a circle.

### Radius of the circle

We can calculate the radius a charged particle will move in by using our equation for the force on a charged particle in a magnetic field and a centripetal force equation.

$$F = BQv \text{ and } F = \frac{mv^2}{r} \text{ are equal to each other so we can write } BQv = \frac{mv^2}{r} \rightarrow r = \frac{mv^2}{BQv} \rightarrow r = \frac{mv}{BQ}$$

### Time for a complete circle

We can also calculate the time it takes for the charged particle to move in one complete circle.

$$\text{Starting at } F = mv\omega \text{ we can use } \omega = 2\pi f \text{ to make the equation become } F = mv2\pi f \text{ and then } F = \frac{mv2\pi}{T}$$

The centripetal force is due to the magnetic force on the charged particle so we can put these equal to each

$$\text{other. } BQv = \frac{mv2\pi}{T} \text{ cancel the } v \text{ to become } BQ = \frac{m2\pi}{T} \text{ which rearranges to: } \span style="border: 1px solid black; padding: 2px;"> $T = \frac{m2\pi}{BQ}$$$

So the time it takes to complete a full circle does not depend on the velocity.

## The Cyclotron

A cyclotron is a particle accelerator. It consists of two hollow D-shaped electrodes (called 'dees') that are attached to an alternating p.d. supply. The dees are placed in vacuum chamber and a magnetic field which acts at right angles to them.

A particle will move in a circle because of the magnetic field.

When it reaches the gap between the dees the alternating supply has made the other dee have the opposite charge to the particle. This causes the particle to accelerate across the gap and enter the second dee. This continues to happen until the particle is moving at the required speed. At this point it leaves the cyclotron.

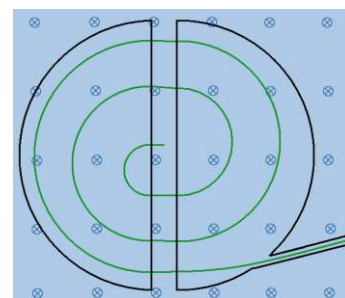

## The Mass Spectrometer

A mass spectrometer is used to analyse the types of atom that are in a sample. The atoms are given a charge, accelerated and sent into a magnetic field. If we look at the radius equation above we can see that atoms travelling at the same speed in the same magnetic field given the same charge will be deflected based on their mass. Heavy atoms will move in bigger circles than lighter ones.

## Pair Production

If we think back to Unit 1 we saw this phenomenon in action. Pair production is when a photon of energy is converted into a particle and an antiparticle, such as an electron and a positron. If this happens in a magnetic field the electron will move in a circle in one direction and the positron will move in a circle in the other direction.

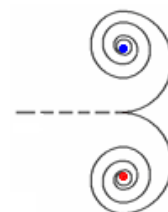

Unit 6	Mr Shepherd	
	<h1>Magnetic Flux and Flux Linkage</h1>	
Learning Outcomes	To be able to calculate and explain the magnetic flux through a coil of wire	
	To be able to calculate the magnetic flux linkage of a coil of wire	
	To be able to calculate the magnetic flux linkage of a rotating coil	

## Magnetic Flux, $\phi$

Magnetic flux is a measure of how many magnetic field lines are passing through an area of  $A \text{ m}^2$ .

The magnetic flux through an area  $A$  in a magnetic field of flux density  $B$  is given by:  $\phi = BA$

This is when  $B$  is **perpendicular** to  $A$ , so the normal to the area is in the same direction as the field lines.

**Magnetic Flux is measured in Webers, Wb**

The more field pass through area  $A$ , the greater the concentration and the stronger magnetic field.

This is why a magnet is strongest at its poles; there is a high concentration of field lines.

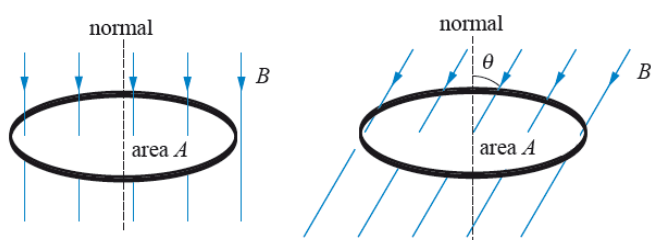

We can see that the amount of flux flowing through a loop of wire depends on the angle it makes with the field lines. The amount of flux passing through the loop is given by:

$\theta$  is the angle that the normal to the loop makes with the field lines.

## Magnetic Flux Density

We can now see why  $B$  is called the magnetic flux density. If we rearrange the top equation for  $B$  we get:

$B = \frac{\phi}{A}$  So  $B$  is a measure of how many flux lines (field lines) passes through each unit area (per  $\text{m}^2$ ).

A flux density of 1 Tesla is when an area of 1 metre squared has a flux of 1 Weber.

## Flux Linkage

We now know that the amount of flux through one loop of wire is:

$$\phi = BA$$

If we have a coil of wire made up of  $N$  loops of wire the total flux is given by:

$$N\phi = BAN$$

The total amount of flux,  $N\phi$ , is called the *Magnetic Flux Linkage*; this is because we consider each loop of wire to be linked with a certain amount of magnetic flux.

Sometimes flux linkage is represented by  $\Phi$ , so  $\Phi = N\phi$  which makes our equation for flux linkage  $\Phi = BAN$

**Flux Linkage is measured in Webers, Wb**

## Rotating Coil in a Magnetic Field

If we have a rectangle of wire that has an area of  $A$  and we place it in a magnetic field of flux density  $B$ , we have seen that the amount of flux flowing through the wire depends on the angle between it and the flux lines.

The flux linkage at an angle  $\theta$  from the perpendicular to the magnetic field is given by:  $N\phi = BAN \cos \theta$

From our lessons on circular motion we established that the angular speed is given by  $\omega = \frac{\theta}{t}$  which can be

rearranged to  $\theta = \omega t$  and substituted into the equation above to transform it into:

$$N\phi = BAN \cos \omega t$$

When  $t = 0$  the wire is perpendicular to the field so there is a maximum amount of flux.

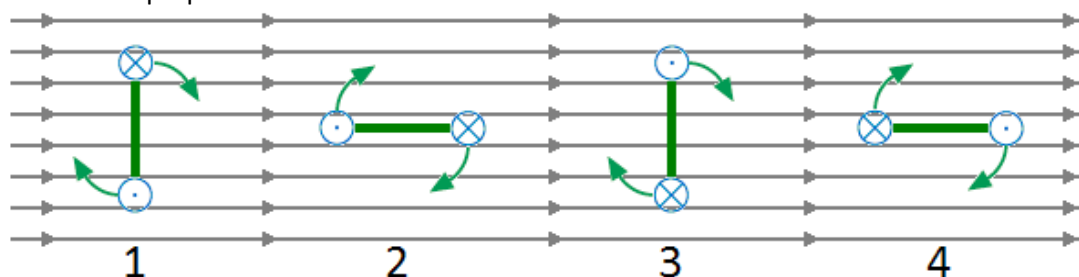

At 1 the flux linkage is a maximum in one direction. There is the lowest rate of change at this point.

At 2 the flux linkage is zero. There is the biggest rate of change at this point

At 3 the flux linkage is maximum but in the opposite direction. The lowest rate of change occurs here too.

At 4 the flux linkage is zero. There is the biggest rate of change at the point too but in the opposite direction.

Next lesson we will be looking at inducing an e.m.f. using a wire and a magnetic field. The size of the e.m.f. depends on the rate of change of flux linkage.

Unit 6	Mr Shepherd	
	<h1>Electromagnetic Induction</h1>	
Learning Outcomes	To know how emf and current are induced	
	To know Faraday's Law and be able to use it to describe the induced emf	
	To know Lenz's Law and be able to use it to describe the induced emf	

### Making Electricity (Also seen at GCSE Physics 3)

An e.m.f. can be induced across the ends of a conducting wire in two ways:

- 1) Move the wire through a magnetic field
- or 2) Move a magnet through a coil of the wire

In both cases magnetic field lines and wires are cutting through each other. We say that the wire is cutting through the magnetic field lines (although it is fair to say that the field lines are cutting through the wire).

If the conductor is part of a complete circuit a current will be induced through it as well as an e.m.f. across it.

There are two laws that describe the induced e.m.f....

### Faraday's Law - Size of induced e.m.f.

The magnitude of the e.m.f. induced in a conductor equals the rate of change of flux linkages or the rate at which the conductor cuts a magnetic flux.

#### Straight Wire

Imagine a straight piece of wire of length  $l$  is moved through a magnetic field at a velocity  $v$ . If the wire is moving at right angles to the field lines an e.m.f. is induced (because field lines are being cut).

The size of the e.m.f. is given by the equation:

$$\varepsilon = \frac{N\Delta\phi}{\Delta t}$$

For one loop of wire  $\varepsilon = \frac{\Delta\phi}{\Delta t}$  and the flux is given by  $\phi = BA$  which are combine to become  $\varepsilon = \frac{\Delta BA}{\Delta t}$

$B$  is constant so  $\varepsilon = \frac{B\Delta A}{\Delta t}$ .  $\Delta A$  is the area the wire cuts through in a time  $t$  and is given by  $A = l.vt$  so we get:

$\varepsilon = \frac{B\Delta l.vt}{\Delta t}$  The length of the wire and velocity are constant so it becomes  $\varepsilon = \frac{Blv\Delta t}{\Delta t}$  which cancels to:  $\varepsilon = Blv$

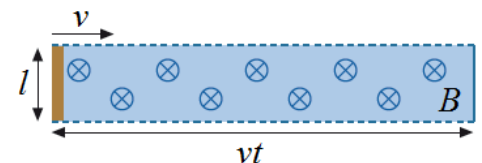

#### Rotating Coil of Wire

If we have a coil of wire with  $N$  turns, each of which has an area of  $A$  and placed it a magnetic field of flux density  $B$  nothing would happen. If it was rotated with an angular speed of  $\omega$  it would cut through the magnetic field lines and an e.m.f. would be induced. The size of the e.m.f. is given by:

Since  $\varepsilon = N \frac{\Delta\phi}{\Delta t}$  and  $\phi = BA \cos \omega t$  we get  $\varepsilon = N \frac{\Delta(BA \cos \omega t)}{\Delta t}$  and if we differentiate it:  $\varepsilon = BAN \omega \sin \omega t$

This is why the Mains supply is alternating; the rotating coil cuts the field lines in one direction on the way up and the other direction on the way down.

### Lenz's Law - Direction of induced e.m.f.

The direction of the e.m.f. induced in a conductor is such that it opposes the change producing it.

#### Solenoid (Right Hand Grip Rule)

A solenoid with a current flowing through it produces a magnetic field like that of a bar magnet. We can work out which end is the North Pole and which is the South by using the Right Hand Grip Rule from our force on a wire lesson. If our fingers follow the direction of the current through the coils our thumb points out of the North Pole.

\*When we push the North Pole of a magnet the induced current in the solenoid flows to make a North Pole to repel the magnet.

\*When we pull the North Pole out of the solenoid the induced current flows to make a South Pole to attract the magnet.

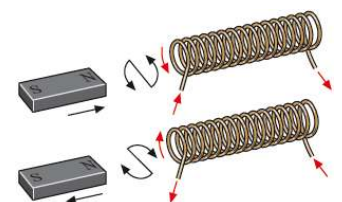
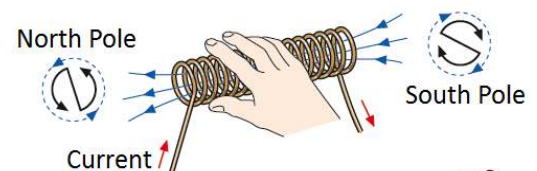

#### Fleming's Right Hand Rule

If we are just moving a straight wire through a uniform magnetic field the direction of the induced current can be worked out using Fleming's Right Hand Rule. Your first finger points in the direction of the field from North to South, your thumb points in the direction the wire is moved and your middle finger points in the direction of the conventional current.

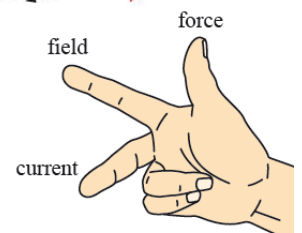

Unit 6	Mr Shepherd <b>Transformers</b>	
Learning Outcomes	To be able to describe a transformer and calculate the voltage and current in the secondary coil	
	To be able to calculate the efficiency of a transformer and explain why they are used	
	To be able to state the causes of inefficiency in transformers	

### **Transformers** (Also seen at GCSE Physics 3)

A transformer is a device used to change the voltage/current of a circuit using electromagnetic induction. It consists of a soft iron core wrapped on both sides with wire. The first coil of wire is called the primary coil and the other coil of wire is called the secondary coil.

A current doesn't flow from one coil of wire to the other.

#### **How They Work**

A current flows through the primary coil which creates a magnetic field.

As this field is established the field lines cut through the turns of wire on the secondary coil. This induces an e.m.f. (voltage) and a current in the second coil.

Since the supply to the primary coil is constantly changing direction the magnetic field is constantly changing direction. This means the secondary coil also has an alternating e.m.f. and current.

An iron core is used because it is easily magnetised and demagnetised and conducts the magnetic field.

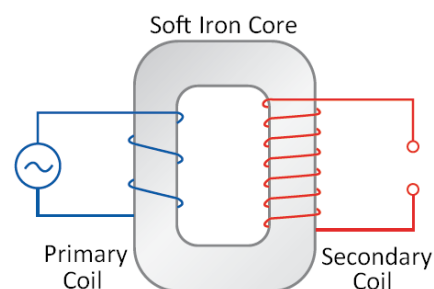

### **Transforming Voltage and Current** (Also seen at GCSE Physics 3)

There are two types of transformers:

#### **Step Up**

The voltage in the secondary coil is larger than the voltage in the primary coil.

The current in the secondary coil is smaller than the current in the primary coil.

*There will be more turns of wire on the secondary coil meaning more flux linkage*

#### **Step Down**

The voltage in the secondary coil is smaller than the voltage in the primary coil.

The current in the secondary coil is larger than the current in the primary coil.

*There will be fewer turns of wire on the secondary coil meaning less flux linkage*

In both cases the voltage and current ( $V_P$  and  $I_P$ ) in the primary coil of  $N_P$  turns is linked to the voltage and current ( $V_S$  and  $I_S$ ) in the secondary coil of  $N_S$  turns by the following equation:

$$\frac{N_S}{N_P} = \frac{V_S}{V_P} = \frac{I_P}{I_S}$$

### **The National Grid** (Also seen at GCSE Physics 1)

The National Grid is a system of transformers that increases the voltage (reducing the current) of an alternating electrical supply as it leaves the power station. Thick cables held above the ground by pylons carry the supply to our neighbourhood. A second series of transformers lowers the voltage to a safe level and increases the current to be used in our homes.

#### **Why Bother?**

Energy is lost in the transmission of electricity. The electrons flowing in the wire are constantly colliding with the positive ions of the metal that the wire is made from. If we increase the voltage of a supply this lowers the current. Lowering the current reduces the number of collisions happening per second hence reducing the amount of energy lost in reaching our homes.

The cables that carry the current have a larger cross sectional area, this lowers the resistance and energy lost.

### **Efficiency of a Transformer**

The efficiency of a transformer can be calculated using the following equation:

$$\text{Efficiency} = \frac{I_S V_S}{I_P V_P}$$

The efficiency of a transformer can be increased by:

\*Using low resistance windings to reduce the power wasted due to the heating effect of the current.

\*Use a laminated core which consists of layers of iron separated by layers of insulation. This reduces heating in the iron core and currents being induced in the core itself (referred to as eddy currents).

Unit 6	Mr Shepherd	
	<h1>Rutherford Scattering</h1>	
Learning Outcomes	To know the set up of Rutherford's experiment and the results he found	
	To be able to explain how the results are evidence for the nucleus	
	To know the factors we must consider when choosing the particle we will scatter	

### Rutherford's Scattering Experiment *(Also seen in GCSE Physics 2)*

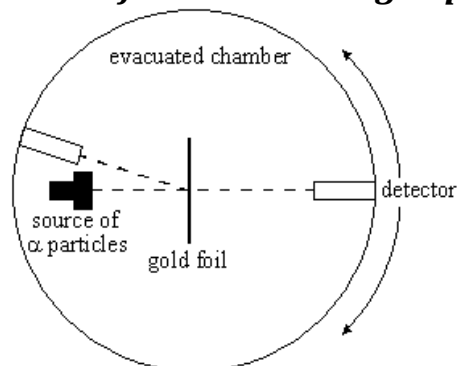

Hans Geiger and Ernest Marsden worked with Ernest Rutherford in his Manchester laboratories in 1909. They fired alpha particles (which they knew to have a positive charge) of a few MeV into a thin piece of gold foil. This was done in an evacuated chamber connected to a vacuum pump. When the alpha particles passed through the gold foil they hit a zinc sulphide screen which emits light whenever an alpha particle strikes it. This screen was observed using a moving microscope in a dark room. At the time the accepted structure of the atom was like a plum pudding: positive dough spread evenly with negative electrons scattered through out it like plums in a pudding.

### Results *(Also seen in GCSE Physics 2)*

Geiger and Marsden found that almost all of the alpha particles passed through with little or no deflection. Rutherford suggested moving the microscope in front of the foil, when they did they found that about 1 in every 8000 was 'reflected' back or scattered through an angle of more than 90°. If the plum pudding model was the structure of the atom this would be like firing a bullet at a piece of toilet paper and it bouncing back – mental!

### The Nuclear Model *(Also seen in GCSE Physics 2)*

Rutherford used these results to make the following conclusions:

- ✱ Most of the mass must be gathered in one small volume – the nucleus.  
*They can repel a fast moving alpha particle*
- ✱ The nucleus must be positively charged.  
*They repel positive alpha particles*
- ✱ Most of the atom is empty space.  
*Only 1 in 8000 alpha particles are deflected*
- ✱ Negative electrons orbit the nucleus at a large distance from it.  
*Negative charges are needed to keep the atom neutral*

### Which Particle to Use?

There are two things to consider when using scattering to find the structure of things: the particle and the energy

**Alpha Scattering:** Rutherford used alpha particles with energies around 4MeV, any higher and it would be close enough to the nucleus to experience the strong nuclear force.

**Electron Scattering:** Electrons are accelerated to high energies of around 6GeV. They have enough energy to be scattered within protons and neutrons; discovering quarks. Electrons travelling at this speed have a de Broglie wavelength 1000 times smaller than visible light meaning we can see more detail.

**X-ray Scattering:** X-ray photons have short wavelengths and can be scattered or completely absorbed by atomic electrons. If the electron is tightly bound or the photon has very little energy the electron remains in the atom and the photon loses no energy. This is known as elastic or coherent scattering. If the photon has enough energy it knocks the electron out of orbit (ionisation) and does lose energy.

**Neutron Scattering:** Very useful because they are not charged but this limits the energies they can be accelerated to. Neutrons interact weakly with other nuclei and do not interact with electrons at all, because of this they can penetrate further.

Their wavelengths are similar to that of atomic spacing, meaning that diffraction will occur.

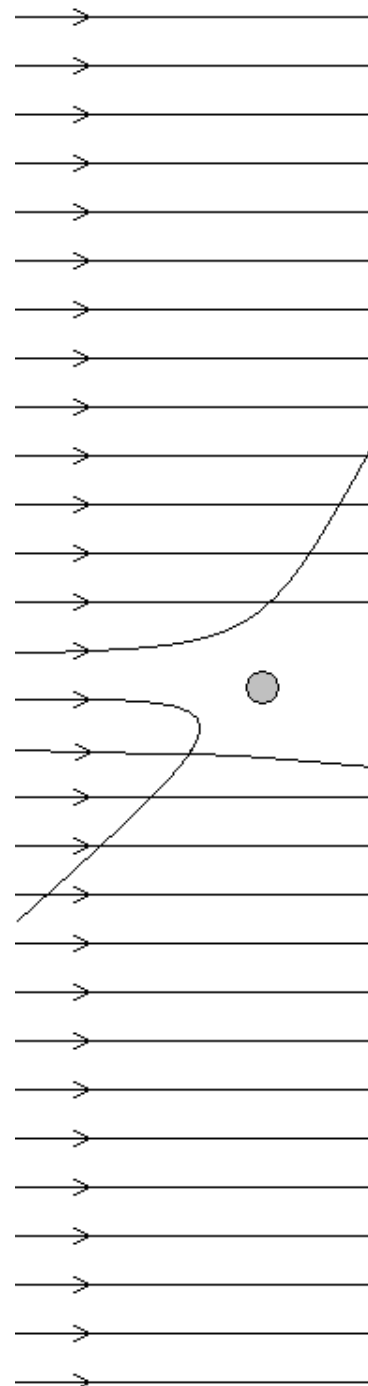



Unit 6	Mr Shepherd	
	<h1>Feynman Diagrams</h1>	
Learning Outcomes	To know what a Feynman diagram shows us	
	To be able to draw Feynman diagrams to represent interactions and decays	
	To be able to state the correct exchange particle	

## Feynman Diagrams

An American Physicist called Richard Feynman came up with a way of visualising forces and exchange particles. Below are some examples of how Feynman diagrams can represent particle interactions.

The most important things to note when dealing with Feynman diagrams are the arrows and the exchange particles, the lines do not show us the path that the particles take only which come in and which go out.

*The arrows tell us which particles are present before the interaction and which are present after the interaction.*

*The wave represents the interaction taking place with the appropriate exchange particle labelled.*

## Examples

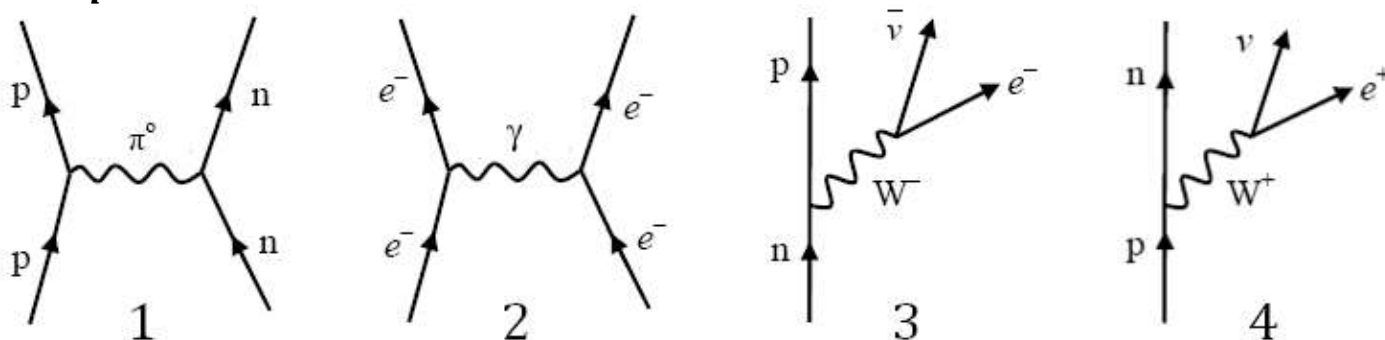

Diagram 1 represents the strong interaction. A proton and neutron are attracted together by the exchange of a neutral pion.

Diagram 2 represents the electromagnetic interaction. Two electrons repel each other by the exchange of a virtual photon.

Diagram 3 represents beta minus decay. A neutron decays due to the weak interaction into a proton, an electron and an anti electron neutrino

Diagram 4 represents beta plus decay. A proton decays into a neutron, a positron and an electron neutrino.

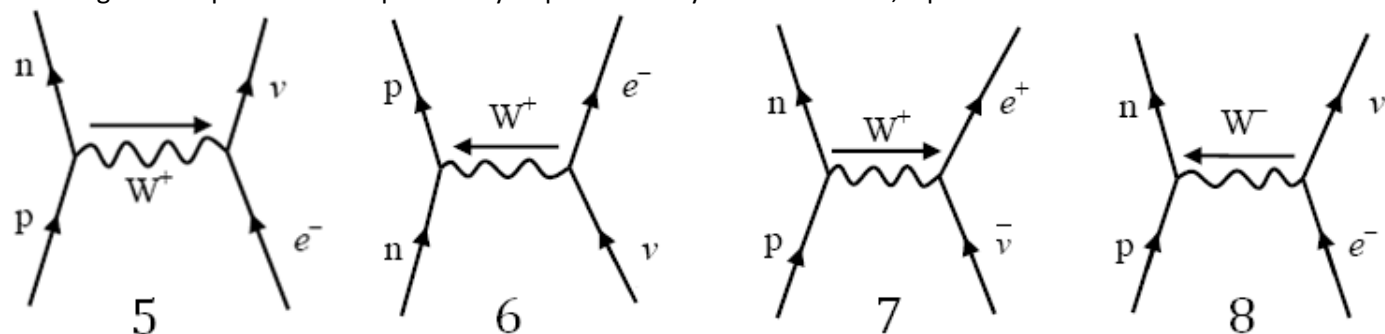

Diagram 5 represents electron capture. A proton captures an electron and becomes a neutron and an electron neutrino.

Diagram 6 represents a neutrino-neutron collision. A neutron absorbs a neutrino and forms a proton and an electron.

Diagram 7 represents an antineutrino-proton collision. A proton absorbs an antineutrino and emits a neutron and an electron.

Diagram 8 represents an electron-proton collision. They collide and emit a neutron and an electron neutrino.

## Getting the Exchange Particle

The aspect of Feynman diagrams that students often struggle with is labelling the exchange particle and the direction to draw it. Look at what you start with:

If it is positive and becomes neutral you can think of it as throwing away its positive charge so the boson will be positive. This is the case in electron capture.

If it is positive and becomes neutral you can think of it as gaining negative to neutralise it so the boson will be negative. This is the case in electron-proton collisions.

If it is neutral and becomes positive we can think of it either as gaining positive ( $W^+$  boson) or losing negative ( $W^-$  boson in the opposite direction).

*Work out where the charge is going and label it.*

Unit 6	Mr Shepherd	
	<h1>Constituents of the Atom</h1>	
Learning Outcomes	To be know the constituents of the atom with their masses and charges	
	To be able to calculate the specific charge of the constituents	
	To be able to explain what isotopes and ions are	

### The Nuclear Model *(Also seen in GCSE Physics 1 and 2)*

We know from Rutherford's experiment that the structure of an atom consists of positively charged protons and neutral neutrons in one place called the nucleus. The nucleus sits in the middle of the atom and has negatively charged electrons orbiting it. At GCSE we used charges and masses for the constituents relative to each other, the table above shows the actual charges and masses.

Constituent	Charge (C)	Mass (kg)
Proton	$1.6 \times 10^{-19}$	$1.673 \times 10^{-27}$
Neutron	0	$1.675 \times 10^{-27}$
Electron	$-1.6 \times 10^{-19}$	$9.1 \times 10^{-31}$

Almost all of the mass of the atom is in the tiny nucleus which takes up practically no space when compared to the size of the atom. If we shrunk the Solar System so that the Sun was the size of a gold nucleus the furthest electron would be twice the distance to Pluto.

If the nucleus was a full stop it would be 25 m to the first electron shell, 100 to the second and 225 to the third.

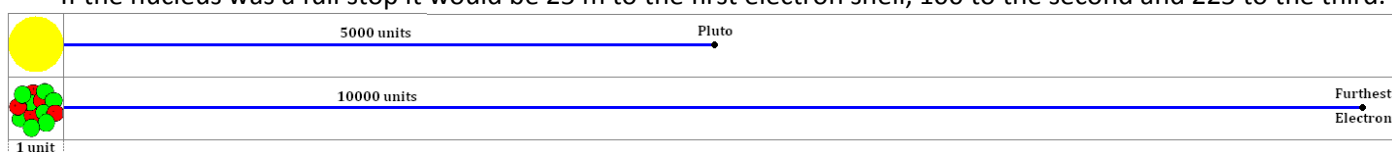

### Notation *(Also seen in GCSE Physics 2)*

We can represent an atom of element X in the following way:



Z is the proton number. This is the number of protons in the nucleus. In an uncharged atom the number of electrons orbiting the nucleus is equal to the number of protons.

*In Chemistry it is called the atomic number*

A is the nucleon number. This is the total number of nucleons in the nucleus (protons + neutrons) which can be written as  $A = Z + N$ .

*In Chemistry it is called the atomic mass number*

N is the neutron number. This is the number of neutrons in the nucleus.

### Isotopes *(Also seen in GCSE Physics 1 and 2)*

Isotopes are different forms of an element. They always have the same number of protons but have a different number of neutrons. Since they have the same number of protons (and electrons) they behave in the same way chemically.

**Chlorine** If we look at Chlorine in the periodic table we see that it is represented by  ${}^{35.5}_{17}Cl$ . How can it have 18.5 neutrons? It can't! There are two stable isotopes of Chlorine,  ${}^{35}_{17}Cl$  which accounts for ~75% and  ${}^{37}_{17}Cl$  which accounts for ~25%. So the average of a large amount of Chlorine atoms is  ${}^{35.5}_{17}Cl$ .

### Specific Charge

Specific charge is another title for the charge-mass ratio. This is a measure of the charge per unit mass and is simply worked out by dividing the charge of a particle by its mass.

You can think of it as a how much charge (in Coulombs) you get per kilogram of the 'stuff'.

Constituent	Charge (C)	Mass (kg)	Charge-Mass Ratio (C kg <sup>-1</sup> ) or (C/kg)	
Proton	$1.6 \times 10^{-19}$	$1.673 \times 10^{-27}$	$1.6 \times 10^{-19} \div 1.673 \times 10^{-27}$	$9.58 \times 10^7$
Neutron	0	$1.675 \times 10^{-27}$	$0 \div 1.675 \times 10^{-27}$	0
Electron	$(-) 1.6 \times 10^{-19}$	$9.1 \times 10^{-31}$	$1.6 \times 10^{-19} \div 9.11 \times 10^{-31}$	$(-) 1.76 \times 10^{11}$

We can see that the electron has the highest charge-mass ratio and the neutron has the lowest.

### Ions *(Also seen in GCSE Physics 2)*

An atom may gain or lose electrons. When this happens the atoms becomes electrically charged (positively or negatively). We call this an ion.

If the atom gains an electron there are more negative charges than positive, so the atom is a negative ion.

Gaining one electron would mean it has an overall charge of -1, which actually means  $-1.6 \times 10^{-19}C$ .

Gaining two electrons would mean it has an overall charge of -2, which actually means  $-3.2 \times 10^{-19}C$ .

If the atom loses an electron there are more positive charges than negative, so the atom is a positive ion.

Losing one electron would mean it has an overall charge of +1, which actually means  $+1.6 \times 10^{-19}C$ .

Losing two electrons would mean it has an overall charge of +2, which actually means  $+3.2 \times 10^{-19}C$ .

Unit 6	Mr Shepherd	
	<h1>Particles and Antiparticles</h1>	
Learning Outcomes	To know what is the difference between particles and antiparticles	
	To be able to explain what annihilation is	
	To be able to explain what pair production is	

## Antimatter

British Physicist Paul Dirac predicted a particle of equal mass to an electron but of opposite charge (positive). This particle is called a positron and is the electron's *antiparticle*.

Every particles has its own antiparticle. An antiparticle has the same mass as the particle version but has opposite charge. An antiproton has a negative charge, an antielectron has a positive charge but an antineutron is also uncharged like the particle version.

American Physicist Carl Anderson observed the positron in a cloud chamber, backing up Dirac's theory.

*Anti particles have opposite Charge, Baryon Number, Lepton Number and Strangeness.*

*If they are made from quarks the antiparticle is made from antiquarks*

## Annihilation

Whenever a particle and its antiparticle meet they annihilate each other. Annihilation is the process by which mass is converted into energy, particle and antiparticle are transformed into two photons of energy.

Mass and energy are interchangeable and can be converted from one to the other. Einstein linked energy and mass with the equation:

$$E = mc^2$$

You can think of it like money; whether you have dollars or pounds you would still have the same amount of money. So whether you have mass or energy you still have the same amount.

The law of conservation of energy can now be referred to as the conservation of mass-energy.

*The total mass-energy before is equal to the total mass-energy after.*



## Photon

Max Planck had the idea that light could be released in 'chunks' or packets of energy. Einstein named these wave-packets photons. The energy carried by a photon is given by the equation:

$$E = hf$$

Since  $c = f\lambda$  we can also write this as:  $E = \frac{hc}{\lambda}$

## How is there anything at all?

When the Big Bang happened matter and antimatter was produced and sent out expanding in all directions. A short time after this there was an imbalance in the amount of matter and antimatter. Since there was more matter all the antimatter was annihilated leaving matter to form protons, atoms and everything around us.

## Pair Production

Pair production is the opposite process to annihilation, energy is converted into mass. A single photon of energy is converted into a particle-antiparticle pair. (This happens to obey the conservation laws)

This can only happen if the photon has enough mass-energy to "pay for the mass".

Let us image mass and energy as the same thing, if two particles needed 10 "bits" and the photon had 8 bits there is not enough for pair production to occur.

If two particles needed 10 bits to make and the photon had 16 bits the particle-antiparticle pair is made and the left over is converted into their kinetic energy.



If pair production occurs in a magnetic field the particle and antiparticle will move in circles of opposite direction but only if they are charged. (The deflection of charges in magnetic fields will be covered in Unit 4: Force on a Charged Particle)

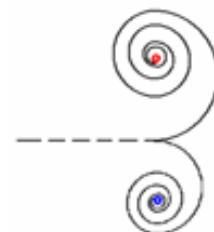

Pair production can occur spontaneously but must occur near a nucleus which recoils to help conserve momentum. It can also be made to happen by colliding particles. At CERN protons are accelerated and fired into each other. If they have enough kinetic energy when they collide particle-antiparticle pair may be created from the energy.

The following are examples of the reactions that have occurred:

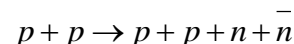
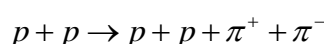
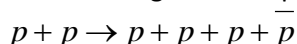

In all we can see that the conservation laws of particle physics are obeyed.

Unit 6	Mr Shepherd	
	<h1>Quarks</h1>	
Learning Outcomes	To know what quarks are and where they are found	
	To be able to explain how they were discovered	
	To know the properties of each type of quark	

### Rutherford *Also seen in GCSE Physics 2*

Rutherford fired a beam of alpha particles at a thin gold foil. If the atom had no inner structure the alpha particles would only be deflected by very small angles. Some of the alpha particles were scattered at large angles by the nuclei of the atoms. From this Rutherford deduced that the atom was mostly empty space with the majority of the mass situated in the centre. Atoms were made from smaller particles.

### Smaller Scattering

In 1968 Physicists conducted a similar experiment to Rutherford's but they fired a beam of high energy electrons at nucleons (protons and neutrons). The results they obtained were very similar to Rutherford's; some of the electrons were deflected by large angles. If the nucleons had no inner structure the electrons would only be deflected by small angles. These results showed that protons and neutrons were made of three smaller particles, each with a fractional charge.

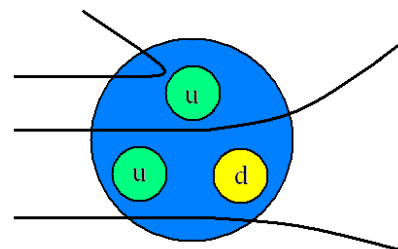

### Quarks

These smaller particles were named quarks and are thought to be fundamental particles (not made of anything smaller). There are six different quarks and each one has its own antiparticle.

We need to know about the three below as we will be looking at how larger particles are made from different combinations of quarks and antiquarks.

Quark	Charge (Q)	Baryon Number (B)	Strangeness (S)
d	$-\frac{1}{3}$	$+\frac{1}{3}$	0
u	$+\frac{2}{3}$	$+\frac{1}{3}$	0
s	$-\frac{1}{3}$	$+\frac{1}{3}$	-1

Anti Quark	Charge (Q)	Baryon Number (B)	Strangeness (S)
$\bar{d}$	$+\frac{1}{3}$	$-\frac{1}{3}$	0
$\bar{u}$	$-\frac{2}{3}$	$-\frac{1}{3}$	0
$\bar{s}$	$+\frac{1}{3}$	$-\frac{1}{3}$	+1

The other three are Charm, Bottom and Top. You will not be asked about these three

Quark	Charge	Baryon No.	Strangeness	Charmness	Bottomness	Topness
d	$-\frac{1}{3}$	$+\frac{1}{3}$	0	0	0	0
u	$+\frac{2}{3}$	$+\frac{1}{3}$	0	0	0	0
s	$-\frac{1}{3}$	$+\frac{1}{3}$	-1	0	0	0
c	$+\frac{2}{3}$	$+\frac{1}{3}$	0	+1	0	0
b	$-\frac{1}{3}$	$+\frac{1}{3}$	0	0	-1	0
t	$+\frac{2}{3}$	$+\frac{1}{3}$	0	0	0	+1

### The Lone Quark?

Never! Quarks never appear on their own. The energy required to pull two quarks apart is so massive that it is enough to make two new particles. A quark and an antiquark are created, another example of pair production.

A particle called a neutral pion is made from an up quark and an antiup quark.

Moving these apart creates another up quark and an antiup quark. We now have two pairs of quarks.

Trying to separate two quarks made two more quarks.

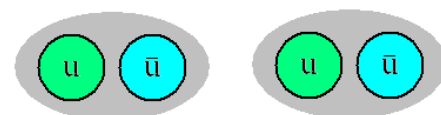
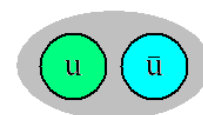

### Particle Classification

Now that we know that quarks are the smallest building blocks we can separate all other particles into two groups, those made from quarks and those that aren't made from quarks.

Hadrons – Heavy and made from smaller particles

Leptons – Light and not made from smaller particles

This document is available free of charge on



Unit 6	Mr Shepherd		
	<h1>Hadrons</h1>		
Learning Outcomes	To know what a hadron is and the difference between the two types		
	To know the properties common to all hadrons		
	To know the structure of the common hadrons and which is the most stable		

### Made from Smaller Stuff

Hadrons, the Greek for 'heavy' are not fundamental particles they are all made from smaller particles, quarks.

The properties of a hadron are due to the combined properties of the quarks that it is made from.

There are two categories of Hadrons: Baryons and Mesons.

#### Baryons Made from three quarks

Proton	Charge (Q)	Baryon Number (B)	Strangeness (S)
u	$+\frac{2}{3}$	$+\frac{1}{3}$	0
u	$+\frac{2}{3}$	$+\frac{1}{3}$	0
d	$-\frac{1}{3}$	$+\frac{1}{3}$	0
<b>p</b>	<b>+1</b>	<b>+1</b>	<b>0</b>

Neutron	Charge (Q)	Baryon Number (B)	Strangeness (S)
d	$-\frac{1}{3}$	$+\frac{1}{3}$	0
u	$+\frac{2}{3}$	$+\frac{1}{3}$	0
d	$-\frac{1}{3}$	$+\frac{1}{3}$	0
<b>n</b>	<b>0</b>	<b>+1</b>	<b>0</b>

The proton is the only stable hadron, all others eventually decay into a proton.

#### Mesons Made from a quark and an antiquark

Pion Plus	Charge (Q)	Baryon Number (B)	Strangeness (S)
u	$+\frac{2}{3}$	$+\frac{1}{3}$	0
$\bar{d}$	$+\frac{1}{3}$	$-\frac{1}{3}$	0
<b><math>\pi^+</math></b>	<b>+1</b>	<b>0</b>	<b>0</b>

Pion Minus	Charge (Q)	Baryon Number (B)	Strangeness (S)
$\bar{u}$	$-\frac{2}{3}$	$-\frac{1}{3}$	0
d	$-\frac{1}{3}$	$+\frac{1}{3}$	0
<b><math>\pi^-</math></b>	<b>-1</b>	<b>0</b>	<b>0</b>

Pion Zero	Charge (Q)	Baryon Number (B)	Strangeness (S)
u	$+\frac{2}{3}$	$+\frac{1}{3}$	0
$\bar{u}$	$-\frac{2}{3}$	$-\frac{1}{3}$	0
<b><math>\pi^0</math></b>	<b>0</b>	<b>0</b>	<b>0</b>

Pion Zero	Charge (Q)	Baryon Number (B)	Strangeness (S)
d	$-\frac{1}{3}$	$+\frac{1}{3}$	0
$\bar{d}$	$+\frac{1}{3}$	$-\frac{1}{3}$	0
<b><math>\pi^0</math></b>	<b>0</b>	<b>0</b>	<b>0</b>

Kaon Plus	Charge (Q)	Baryon Number (B)	Strangeness (S)
u	$+\frac{2}{3}$	$+\frac{1}{3}$	0
$\bar{s}$	$+\frac{1}{3}$	$-\frac{1}{3}$	+1
<b><math>K^+</math></b>	<b>+1</b>	<b>0</b>	<b>+1</b>

Kaon Minus	Charge (Q)	Baryon Number (B)	Strangeness (S)
$\bar{u}$	$-\frac{2}{3}$	$-\frac{1}{3}$	0
s	$-\frac{1}{3}$	$+\frac{1}{3}$	-1
<b><math>K^-</math></b>	<b>-1</b>	<b>0</b>	<b>-1</b>

Kaon Zero	Charge (Q)	Baryon Number (B)	Strangeness (S)
d	$-\frac{1}{3}$	$+\frac{1}{3}$	0
$\bar{s}$	$+\frac{1}{3}$	$-\frac{1}{3}$	+1
<b><math>K^0</math></b>	<b>0</b>	<b>0</b>	<b>+1</b>

AntiKaon Zero	Charge (Q)	Baryon Number (B)	Strangeness (S)
$\bar{d}$	$+\frac{1}{3}$	$-\frac{1}{3}$	0
s	$-\frac{1}{3}$	$+\frac{1}{3}$	-1
<b><math>\bar{K}^0</math></b>	<b>0</b>	<b>0</b>	<b>-1</b>

### Anti Hadrons

Anti hadrons are made from the opposite quarks as their Hadron counterparts, for example a proton is made from the quark combination uud and an antiproton is made from the combination  $\bar{u}\bar{u}\bar{d}$

We can see that a  $\pi^+$  and a  $\pi^-$  are particle and antiparticle of each other.

Anti Proton	Charge (Q)	Baryon Number (B)	Strangeness (S)
$\bar{u}$	$-\frac{2}{3}$	$-\frac{1}{3}$	0
$\bar{u}$	$-\frac{2}{3}$	$-\frac{1}{3}$	0
$\bar{d}$	$+\frac{1}{3}$	$-\frac{1}{3}$	0
<b><math>\bar{p}</math></b>	<b>-1</b>	<b>-1</b>	<b>0</b>

Anti Neutron	Charge (Q)	Baryon Number (B)	Strangeness (S)
$\bar{d}$	$+\frac{1}{3}$	$-\frac{1}{3}$	0
$\bar{u}$	$-\frac{2}{3}$	$-\frac{1}{3}$	0
$\bar{d}$	$+\frac{1}{3}$	$-\frac{1}{3}$	0
<b><math>\bar{n}</math></b>	<b>0</b>	<b>-1</b>	<b>0</b>

You need to know all the quark combination shown on this page as they may ask you to recite any of them.

Unit 6	Mr Shepherd	
	<h1>Leptons</h1>	
Learning Outcomes	To be able to explain what a lepton is	
	To know the properties common to all leptons	
	To be able to explain the conservation laws and be able to use them	

## Fundamental Particles

A fundamental particle is a particle which is not made of anything smaller. Baryons and Mesons are made from quarks so they are not fundamental, but quarks themselves are. The only other known fundamental particles are Bosons (see Lesson 6: Forces and Exchange Particles) and Leptons.

## Leptons

Leptons are a family of particles that are much lighter than Baryons and Mesons and are not subject to the strong interaction. There are six leptons in total, three of them are charged and three are uncharged.

The charged particles are electrons, muons and tauons. The muon and tauon are similar to the electron but bigger. The muon is roughly 200 times bigger and the tauon is 3500 times bigger (twice the size of a proton).

Each of the charged leptons has its own neutrino. If a decay involves a neutrino and a muon, it will be a muon neutrino, not a tauon neutrino or electron neutrino.

The neutrino is a chargeless, almost massless particle. It isn't affected by the strong interaction or EM force and barely by gravity. It is almost impossible to detect.

Lepton		Charge (Q)	Lepton Number (L)
Electron	$e^-$	-1	+1
Electron Neutrino	$\nu_e$	0	+1
Muon	$\mu^-$	-1	+1
Muon Neutrino	$\nu_\mu$	0	+1
Tauon	$\tau^-$	-1	+1
Tauon Neutrino	$\nu_\tau$	0	+1

Anti Lepton		Charge (Q)	Lepton Number (L)
Anti Electron	$e^+$	+1	-1
Anti Electron Neutrino	$\bar{\nu}_e$	0	-1
Anti Muon	$\mu^+$	+1	-1
Anti Muon Neutrino	$\bar{\nu}_\mu$	0	-1
Anti Tauon	$\tau^+$	+1	-1
Anti Tauon Neutrino	$\bar{\nu}_\tau$	0	-1

## Conservation Laws

For a particle interaction to occur the following laws must be obeyed, if either is violated the reaction will never be observed (will never happen):

**Charge:** Must be conserved (same total value before as the total value after)

**Baryon Number:** Must be conserved

**Lepton Number:** Must be conserved

**Strangeness:** Conserved in EM and Strong Interaction. Doesn't have to be conserved in Weak Interaction

## Examples

In pair production a photon of energy is converted into a particle and its antiparticle

	$\gamma$	$\rightarrow$	$e^-$	+	$e^+$				
Q	0	$\rightarrow$	-1	+	+1	0	$\rightarrow$	0	Conserved
B	0	$\rightarrow$	0	+	0	0	$\rightarrow$	0	Conserved
L	0	$\rightarrow$	+1	+	-1	0	$\rightarrow$	0	Conserved
S	0	$\rightarrow$	0	+	0	0	$\rightarrow$	0	Conserved

Let us look at beta plus decay as we knew it at GCSE. A neutron decays into a proton and releases an electron.

	$n$	$\rightarrow$	$p$	+	$e^-$				
Q	0	$\rightarrow$	+1	+	-1	0	$\rightarrow$	0	Conserved
B	+1	$\rightarrow$	+1	+	0	+1	$\rightarrow$	+1	Conserved
L	0	$\rightarrow$	0	+	+1	0	$\rightarrow$	+1	Not Conserved
S	0	$\rightarrow$	0	+	0	0	$\rightarrow$	0	Conserved

This contributed to the search for and discovery of the neutrino.

## Number Reminders

There may be a clue to the charge of a particle;  $\pi^+$ ,  $K^+$  and  $e^+$  have a positive charge.

It will only have a baryon number if it **IS** a baryon. Mesons and Leptons have a Baryon Number of zero.

It will only have a lepton number if it **IS** a lepton. Baryons and Mesons have a Lepton Number of zero.

It will only have a strangeness if it is made from a strange quark. Leptons have a strangeness of zero.



Unit 6	Mr Shepherd	
	<h1>The Strong Interaction</h1>	
Learning Outcomes	To know why a nucleus doesn't tear itself apart	
	To know why a nucleus doesn't collapse in on itself	
	To know why the neutron exists in the nucleus	

## The Strong Interaction

The strong nuclear force acts between quarks. Since Hadrons are the only particles made of quarks only they experience the strong nuclear force.

In both Baryons and Mesons the quarks are attracted to each other by exchanging virtual particles called 'gluons'.

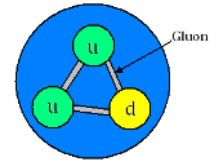

On a larger scale the strong nuclear force acts between the Hadrons themselves, keeping them together. A pi-meson or pion ( $\pi$ ) is exchanged between the hadrons. This is called the residual strong nuclear force.

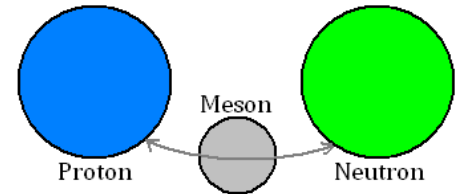

## Force Graphs

### Neutron-Neutron or Neutron-Proton

Here is the graph of how the force varies between two neutrons or a proton and a neutron as the distance between them is increased.

We can see that the force is very strongly repulsive at separations of less than 0.7 fm ( $\times 10^{-15}$  m). This prevents all the nucleons from crushing into each other.

Above this separation the force is strongly attractive with a peak around 1.3 fm. When the nucleons are separated by more than 5 fm they no longer experience the SNF.

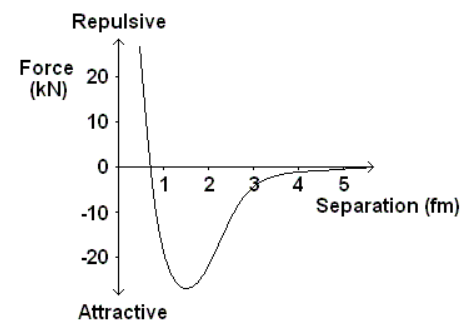

### Proton-Proton

The force-separation graphs for two protons is different. They both attract each other due to the SNF but they also repel each other due to the electromagnetic force which causes two like charges to repel.

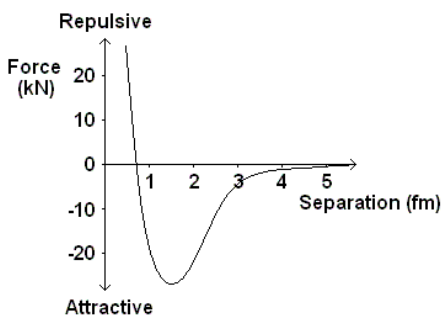

Graph A

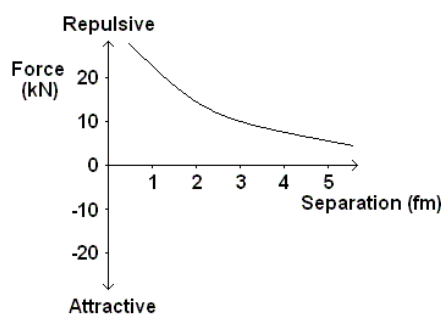

Graph B

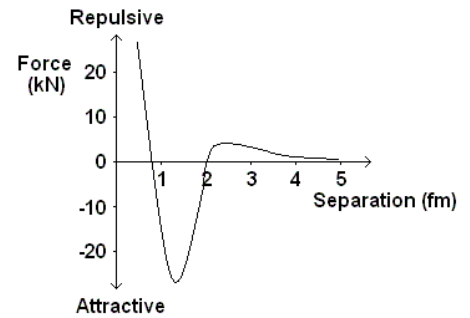

Graph C

Graph A shows how the strong nuclear force varies with the separation of the protons

Graph B shows how the electromagnetic force varies with the separation of the protons

Graph C shows the resultant of these two forces: repulsive at separations less than 0.7 fm, attractive up to 2 fm when the force becomes repulsive again.

## Neutrons - Nuclear Cement

In the lighter elements the number of protons and neutrons in the nucleus is the same. As the nucleus gets bigger more neutrons are needed to keep it together.

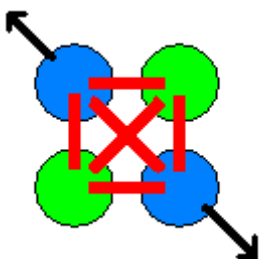

Adding another proton means that all the other nucleons feel the SNF attraction. It also means that all the other protons feel the EM repulsion.

Adding another neutron adds to the SNF attraction between the nucleons but, since it is uncharged, it does not contribute to the EM repulsion.

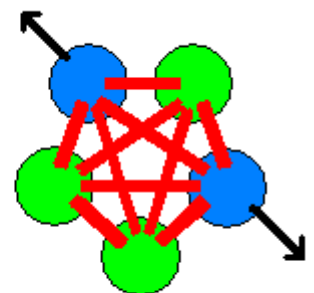
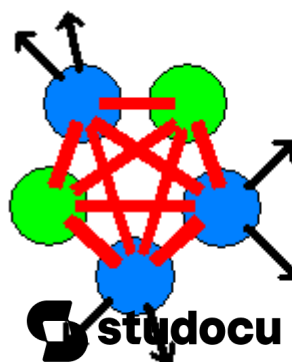



Unit 6	Mr Shepherd <b>The Weak Interaction</b>	
Learning Outcomes	To be able to write the equation for alpha and beta decay	
	To know what a neutrino is and why it must exist	
	To be able to state the changes in quarks during beta plus and beta minus decay	

### Alpha Decay

When a nucleus decays in this way an alpha particle (a helium nucleus) is ejected from the nucleus.

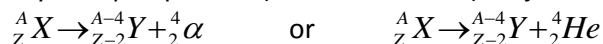

All the emitted alpha particles travelled at the same speed, meaning they had the same amount of energy. The law of conservation of mass-energy is met, the energy of the nucleus before the decay is the same as the energy of the nucleus and alpha particle after the decay.

Alpha decay is NOT due to the weak interaction but Beta decay IS

### Beta Decay and the Neutrino

In beta decay a neutron in the nucleus changes to a proton and releases a beta particle (an electron).

The problem with beta decay was that the electrons had a range of energies so the law of conservation of mass-energy is violated, energy disappears. There must be another particle being made with zero mass but variable speeds, the neutrino.

We can also see from the particle conservation laws that this is a forbidden interaction:  $n \rightarrow p + e^-$

Charge	Q: $0 \rightarrow +1 - 1$	$0 \rightarrow 0$	Charge is conserved
Baryon Number	B: $+1 \rightarrow +1 + 0$	$1 \rightarrow 1$	Baryon number is conserved
Lepton Number	L: $0 \rightarrow 0 + 1$	$0 \rightarrow 1$	Lepton number is NOT conserved

### Beta Minus ( $\beta^-$ ) Decay

In neutron rich nuclei a neutron may decay into a proton, electron and an anti electron neutrino.

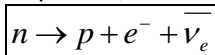

Charge	Q: $0 \rightarrow +1 - 1 + 0$	$0 \rightarrow 0$	Charge is conserved
Baryon Number	B: $+1 \rightarrow +1 + 0 + 0$	$1 \rightarrow 1$	Baryon number is conserved
Lepton Number	L: $0 \rightarrow 0 + 1 - 1$	$0 \rightarrow 0$	Lepton number is conserved

In terms of quarks beta minus decay looks like this:  $dud \rightarrow uud + e^- + \bar{\nu}_e$  which simplifies to:

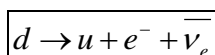

Charge	Q: $-\frac{1}{3} \rightarrow +\frac{2}{3} - 1 + 0$	$-\frac{1}{3} \rightarrow -\frac{1}{3}$	Charge is conserved
Baryon Number	B: $+\frac{1}{3} \rightarrow +\frac{1}{3} + 0 + 0$	$\frac{1}{3} \rightarrow \frac{1}{3}$	Baryon number is conserved
Lepton Number	L: $0 \rightarrow 0 + 1 - 1$	$0 \rightarrow 0$	Lepton number is conserved

### Beta Plus ( $\beta^+$ ) Decay

In proton rich nuclei a proton may decay into a neutron, positron and an electron neutrino.

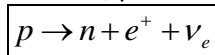

Charge	Q: $+1 \rightarrow 0 + 1 + 0$	$1 \rightarrow 1$	Charge is conserved
Baryon Number	B: $+1 \rightarrow +1 + 0 + 0$	$1 \rightarrow 1$	Baryon number is conserved
Lepton Number	L: $0 \rightarrow 0 - 1 + 1$	$0 \rightarrow 0$	Lepton number is conserved

In terms of quarks beta plus decay looks like this:  $uud \rightarrow dud + e^+ + \nu_e$  which simplifies to:

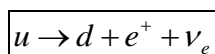

Charge	Q: $+\frac{2}{3} \rightarrow -\frac{1}{3} + 1 + 0$	$\frac{2}{3} \rightarrow \frac{2}{3}$	Charge is conserved
Baryon Number	B: $+\frac{1}{3} \rightarrow +\frac{1}{3} + 0 + 0$	$\frac{1}{3} \rightarrow \frac{1}{3}$	Baryon number is conserved
Lepton Number	L: $0 \rightarrow 0 - 1 + 1$	$0 \rightarrow 0$	Lepton number is conserved

### Strangeness

The weak interaction is the only interaction that causes a quark to change into a different type of quark. In beta decay up quarks and down quarks are changed into one another. In some reactions an up or down quark can change into a strange quark meaning strangeness is not conserved.

During the weak interaction there can be a change in strangeness of  $\pm 1$ .

Unit 6	Mr Shepherd <b>Ionising Radiation</b>	
Learning Outcomes	To know what alpha, beta and gamma are and be able to list their uses and dangers	
	To know the inverse-square law of radiation and be able to calculate intensity at given distances	
	To know what background radiation is and what contributes to it	

### **Ionisation** (Also seen in GCSE Physics 2)

The process of ionisation involves the removal of one or more electron from an atom. When radiation enters a GM tube it may ionise the atoms inside, the electrons are attracted to a positive wire and a small current flows. There are three types of radiation, each with its own properties, uses and dangers.

#### **Alpha:** A Helium nucleus – two protons and two neutrons

**Relative mass:** 4                      **Relative charge:** +2                      **Deflection by E/M field:** Yes  
**Ionising power:** High                      **Penetrating power:** Low                      **Range in air:** 5cm                      **Stopped by:** Skin, paper  
**Uses:** Smoke detectors, radiotherapy to treat cancer  
**Danger out of body:** Low                      **Danger in body:** Cell death, mutation and cancer

#### **Beta:** A fast moving electron

**Relative mass:** 1/2000                      **Relative charge:** -1                      **Deflection by E/M field:** Yes  
**Ionising power:** Medium                      **Penetrating power:** Medium                      **Range in air:** 2-3m                      **Stopped by:** Aluminium  
**Uses:** Thickness control in paper production  
**Danger out of body:** Damage to skin                      **Danger in body:** Similar to alpha but less damage

#### **Gamma:** A high frequency electromagnetic wave

**Relative mass:** 0                      **Relative charge:** 0                      **Deflection by E/M field:** No  
**Ionising power:** Low                      **Penetrating power:** High                      **Range in air:** 15m                      **Slowed by:** Lead, concrete  
**Uses:** Tracers: medical and industrial, sterilising surgical equipment  
**Danger out of body:** Cell death, mutation and cancer                      **Danger in body:** Low

### **The Inverse-Square Law**

Gamma radiation from a source will spread out. The radiation from a small source can be considered the same in all directions (isotropic), imagine a sphere around the source. As we move further away from the source the bigger the sphere gets. The same amount of energy is shared over a greater surface area. The further we move from the source the less intensity of the gamma radiation.

**Intensity is measured in Watts, W**

The intensity,  $I$ , of the radiation at a distance  $x$  from the source is given as  
Where  $I_0$  is the intensity at the source and  $k$  is a constant.

$$I = \frac{kI_0}{x^2}$$

We do not always need to know the intensity at the source to find it at a given distance. Consider two points, A and B, a certain distance away from a gamma source.

$$I_A = \frac{kI_0}{(x_A)^2} \rightarrow I_A(x_A)^2 = kI_0 \quad \text{and} \quad I_B = \frac{kI_0}{(x_B)^2} \rightarrow I_B(x_B)^2 = kI_0$$

We can combine these to give  $I_A(x_A)^2 = kI_0 = I_B(x_B)^2 \rightarrow$

$$I_A(x_A)^2 = I_B(x_B)^2$$

### **Background Radiation** (Also seen in GCSE Physics 2)

We are continuously exposed to a certain level of background radiation. In the lessons to come **you must remember to subtract the background radiation from the recorded radiation** level to get the true (or corrected) reading. The main contributors to background radiation are:

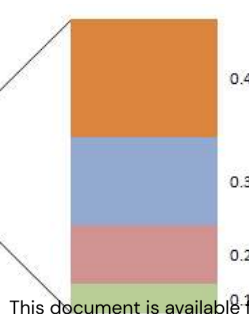
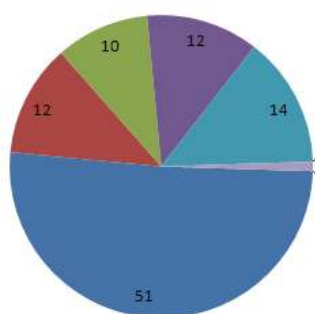

Radon and Thoron gas: 51%  
Ground, rocks and buildings: 14%  
Food and drink: 12%  
Medical: 12%  
Cosmic rays: 10%  
Air travel: 0.4%  
Nuclear weapons testing: 0.3%  
Occupational: 0.2%

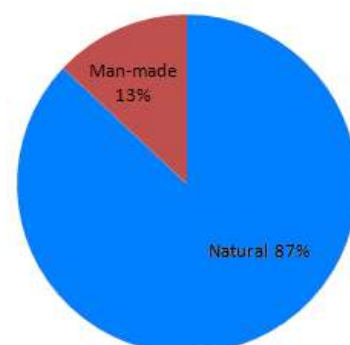

Unit 6	Mr Shepherd <b>Radioactive Decay</b>	
Learning Outcomes	To know what activity is and how to calculate it	
	To know what the decay constant is and how to calculate it	
	To know what half life is and be able to find it by calculation or graphical methods	

### Decay (Also seen in GCSE Physics 1)

Something that is radioactive will decay into something that is stable. Radioactive decay happens randomly and spontaneously: there is no way of predicting when a radioactive nucleus will decay and external factors do not influence it at all (e.g. pressure and temperature).

What we can do is give a probability that a nucleus will decay in a given time.

### Decay Constant, $\lambda$

Every radioactive isotope has its own probability that a nucleus will decay, called the decay constant.

### Activity, $A$

The activity of a radioactive source is the number of decays that happen every second.

1 becquerel is equal to one decay per second, 50 becquerels is equal to 50 decay per second,

**Activity is measured in becquerels, Bq (decays per second,  $s^{-1}$ )**

During a certain amount of time,  $\Delta t$ , some radioactive atoms ( $\Delta N$ ) decay from a sample of  $N$  atoms.

The change in the number of nuclei in a certain time is  $\frac{-\Delta N}{\Delta t} = \lambda N$  this can be written as  $A = -\lambda N$

The minus sign is there because we are losing nuclei, the number we have left is getting smaller.

### Exponential Decay

As time passes the number of nuclei that decay every second will decrease.

To calculate the number of nuclei that we have left after a time,  $t$ , is given by:

$N = N_0 e^{-\lambda t}$

Where  $N_0$  is the number of nuclei at the start and  $N$  is the current number of nuclei. This is similar to the exponential decay equation of a discharging capacitor.

The equation for calculating the activity looks similar:

$A = A_0 e^{-\lambda t}$

### Half-Life (Also seen in GCSE Physics 1)

Each radioactive isotopes has its own half-life. We already know that it is:

*The time it takes for the number of atoms in a sample to drop to half of its original sample* or

*The time it takes for the activity of a substance to drop to half of its original activity*

**Half-Life is measured in seconds, s**

The half life of a substance is linked to the decay constant.

If there is a high probability that a nucleus will decay ( $\lambda = \text{BIG}$ ) then it will not take long before half the sample has decayed to stability (half-life = short).

If there is a low probability that a nucleus will decay ( $\lambda = \text{small}$ ) then it will take a long time for half of the sample to have decayed (half-life = LONG).

$T_{1/2} = \frac{\ln 2}{\lambda}$

where  $T_{1/2}$  is the half life

### Graphs (Also seen in GCSE Physics 1)

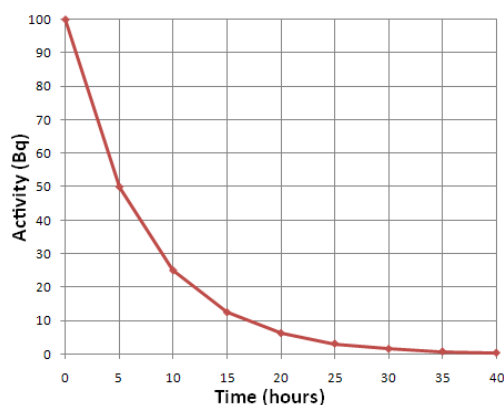

We can calculate the half-life from activity and number of nuclei graphs. Choose a starting value and then find how long it takes to fall to half this value. In the graphs we can see that both fall from 50 to 25 and take 5 hours to do this. Therefore the half-life is 5 hours.

Knowing this we can then calculate the decay constant.

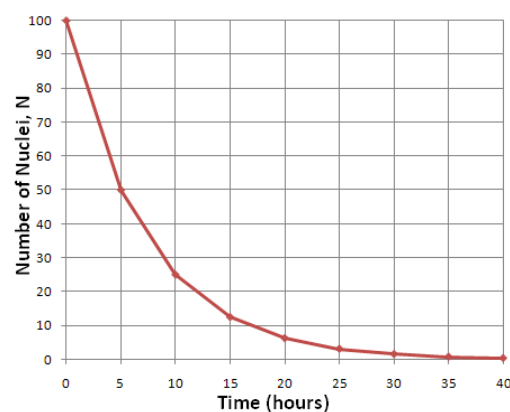

Unit 6	Mr Shepherd <b>Modes of Decay</b>	
Learning Outcomes	To be able to sketch and label a graph of N against Z for stable and unstable nuclei	
	To be able to state the changes to the parent nuclei when it undergoes: $\alpha$ decay, $\beta^-$ decay, $\beta^+$ decay, nucleon emission, electron capture and gamma ray emission	

### N Against Z Graph

Here is a graph of the number of neutrons against the number of protons in a nucleus. It shows stable and unstable nuclei. Stable nuclei/isotopes are found on the black line/dots. The shaded areas above and below the line of stability represent radioactive isotopes.

#### Why doesn't it follow N=Z?

Protons repel each other with the electromagnetic force but the strong nuclear force is stronger at small distances and keeps them together in the nucleus. We can see the line of stability follows N=Z at low values. As the nucleus gets bigger there are more protons, when they become a certain distance apart they no longer experience the strong nuclear force that keeps them together, only the electromagnetic which pushes them apart. To keep the nucleus together we need more neutrons which feel no electromagnetic repulsion only the attraction of the strong nuclear force.

#### Points to remember

Follows N=Z around Z=20, then curves to go through Z=80 N=120  
 $\beta^-$  emitters above the line,  $\beta^+$  emitters below the line and  $\alpha$  at the top

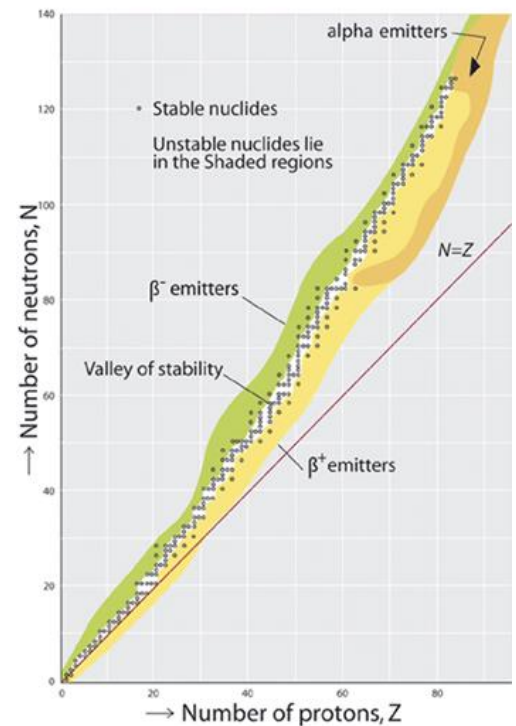

### Alpha Decay (Also seen in GCSE Physics 2)

An alpha particle (a Helium nucleus) is ejected from the parent nucleus.



### Beta Minus Decay (Also seen in GCSE Physics 2)

A neutron is transformed into a proton (that stays in the nucleus) and an electron (which is emitted).

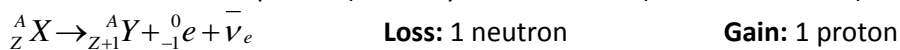

### Beta Plus Decay

A proton is transformed into a neutron and a positron.

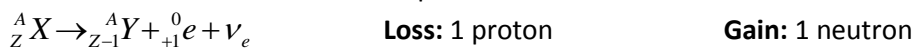

### Electron Capture

A nucleus can capture one of the orbiting electrons. A proton changes into a neutron.

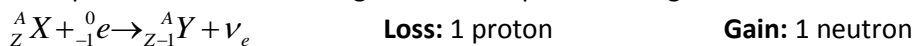

### Nucleon Emission Decay

It is possible for an unstable isotope to emit a nucleon from the nucleus. In proton-rich or proton-heavy nuclei it is possible (though rare) for a proton to be emitted.



In neutron-rich or neutron-heavy nuclei it is possible (though rare) for a neutron to be emitted.



### Gamma Ray Emission (Also seen in GCSE Physics 2)

Alpha emission is often followed by gamma ray emission. The daughter nuclei are left in an excited state (remember energy levels from Unit 1) which they will at some point fall from to the ground state, emitting a gamma photon. There is no nuclear structure change, just a change of energy.

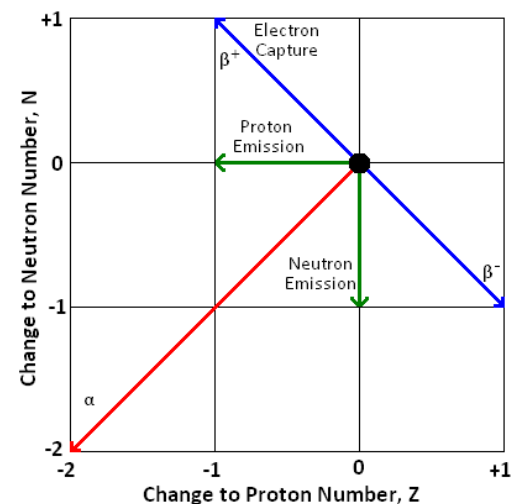

Unit 6	Mr Shepherd <b>Nuclear Radius</b>	
Learning Outcomes	To be able to calculate the radius of a nucleus by the closest approach of alpha particles	
	To be able to calculate the radius of a nucleus by the diffraction angle of electrons	
	To be able to calculate the nuclear radius and nuclear density	

Rutherford gave us an idea of the size of the nucleus compared to the atom but more experimental work has been done to find a more accurate measurement.

### Closest Approach of Alpha Particles

Rutherford fired alpha particles at gold atoms in a piece of foil. They approach the nucleus but slow down as the electromagnetic repulsive force become stronger. Eventually they stop moving, all the kinetic energy has been converted into potential energy as the particles come to rest at a distance  $r$  from the centre of the nucleus.

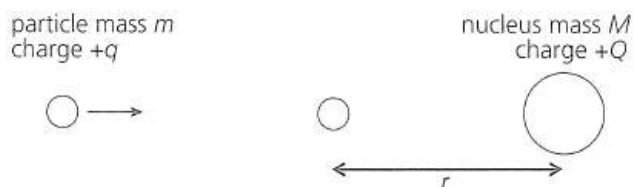

$E_K = E_p \rightarrow E_p = qV$  where  $V$  is the electric potential at a distance of  $r$  from the centre

$$E_p = q \frac{Q}{4\pi\epsilon_0 r} \rightarrow E_K = q \frac{Q}{4\pi\epsilon_0 r} \rightarrow \boxed{r = q \frac{Q}{4\pi\epsilon_0 E_K}}$$

This gives us the upper limit of the radius of a nucleus.

Calculating the nuclear radius this way gives us a value of  $r = 4.55 \times 10^{-14}$  m or 45.5 fm (where 1 fm =  $1 \times 10^{-15}$  m)

Modern measurements give us values of approximately  $r = 6.5$  fm

(Remember that 1 eV of energy is equal to  $1.6 \times 10^{-19}$  J)

### Electron Diffraction

A beam of electrons were fired at a thin sample of atoms and the diffraction pattern was detected and then examined.

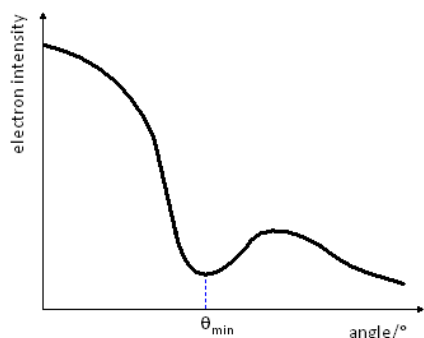
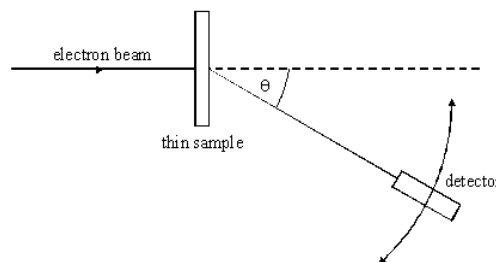

The graph shows a minimum at a value of  $\theta_{\min}$ . We can use this to find a value of the nuclear radius.

$$\boxed{\sin \theta_{\min} = \frac{0.61\lambda}{D}}$$

Where  $D$  is the nuclear radius and  $\lambda$  is the de Broglie wavelength of the beam of electrons. We can calculate this as follows:

The kinetic energy gained by the electrons is  $E_K = eV$  where  $e$  is the charge on the electron and  $V$  is the potential difference used to accelerate it. So we now have:

$$\frac{1}{2}mv^2 = eV \rightarrow mv^2 = 2eV \rightarrow m^2v^2 = 2meV \rightarrow \sqrt{m^2v^2} = \sqrt{2meV} \rightarrow mv = \sqrt{2meV}$$

We can now substitute this into the equation for de Broglie wavelength:  $\lambda = \frac{h}{mv} \rightarrow \boxed{\lambda = \frac{h}{\sqrt{2meV}}}$

### Nuclear Radius

From the experimental results a graph was plotted of  $R$  against  $A$ . A graph like the one to the right was obtained. They saw that  $R$  depends not on  $A$ , but on  $A^{1/3}$ .

When they plotted the graph of  $R$  against  $A^{1/3}$  they found a straight line that cut the origin and had a gradient of  $r_0$ . ( $r_0$  is a constant representing the radius of a single nucleon and has a value of between 1.2 and 1.5 fm)

The radius of a nucleus has been found to be:

$$\boxed{R = r_0 A^{1/3}}$$

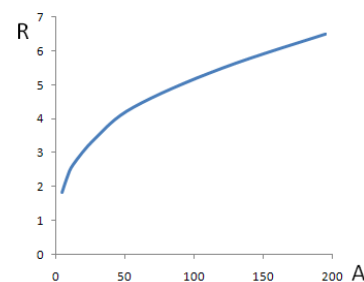

### Nuclear Density

Now that we have an equation for the nuclear radius we can calculate the density of a nucleus.

If we have a nucleus of  $A$  nucleons, we can assume the mass is  $Au$  and the volume is the volume of a sphere:

$$\rho = \frac{m}{V} \rightarrow \rho = \frac{Au}{\frac{4}{3}\pi R^3} \rightarrow \rho = \frac{Au}{\frac{4}{3}\pi (r_0 A^{1/3})^3} \rightarrow \rho = \frac{Au}{\frac{4}{3}\pi r_0^3 A} \rightarrow \rho = \frac{u}{\frac{4}{3}\pi r_0^3}$$

We can see that the density is independent of the nucleon number and gives a value of:  $3.4 \times 10^{17}$  kg m<sup>-3</sup>.

Unit 6	Mr Shepherd	
	<h1>Mass and Energy</h1>	
Learning Outcomes	To be able to explain what mass defect is and be able to calculate	
	To be able to explain what binding energy is and be able to calculate	
	To be able to sketch the graph of B.E. per nucleon against nucleon number	

## Disappearing Mass

The mass of a nucleus is less than the mass of the protons and neutrons that it is made of.

$$(\text{mass of protons} + \text{mass of neutrons}) - \text{mass of nucleus} = \Delta m$$

$\Delta m$  is the difference in the masses and is called the **mass defect**.

Let us look at the nucleus of a Helium atom to see this in action. It is made up of 2 protons and 2 neutrons:

$$\text{Mass of nucleons} = 2 \times (\text{mass of proton}) + 2 \times (\text{mass of neutron})$$

$$\text{Mass of nucleons} = 2 \times (1.673 \times 10^{-27}) + 2 \times (1.675 \times 10^{-27})$$

$$\text{Mass of nucleons} = 6.696 \times 10^{-27} \text{ kg}$$

$$\text{Mass of nucleus} = 6.648 \times 10^{-27} \text{ kg}$$

$$\text{Mass defect} = \text{mass of nucleons} - \text{mass of nucleus}$$

$$\text{Mass defect} = 6.696 \times 10^{-27} - 6.648 \times 10^{-27} = 0.048 \times 10^{-27} \text{ kg}$$

As we can see, we are dealing with tiny masses. For this reason we will use the **atomic mass unit, u**

$$1u = 1.661 \times 10^{-27} \text{ kg}$$

The mass defect now becomes = 0.029 u

Particle	Mass (kg)	Mass (u)
Proton	$1.673 \times 10^{-27}$	1.00728
Neutron	$1.675 \times 10^{-27}$	1.00867
Electron	$9.11 \times 10^{-31}$	0.00055

## Einstein to the Rescue

In 1905, Einstein published his theory of special relativity. In this it is stated that:

$$E = mc^2$$

Energy is equal to the mass multiplied by the speed of light squared.

This means gaining energy means a gain in mass, losing energy means losing mass. The reverse must be true.

Gaining mass means a gain in energy, losing mass means a loss in energy.

The energy we are losing is the binding energy.

$$E = \Delta mc^2$$

where  $\Delta m$  is the mass defect and  $E$  is binding energy

## Binding Energy

As the protons and neutrons come together the strong nuclear force pulls them closer and they lose potential energy. (Like how an object loses its gravitational potential energy as it falls to the Earth.)

Energy must be done against the s.n.f. to separate the nucleus into the nucleons it is made of. This is called the binding energy (although 'unbinding' energy would be a better way to think of it).

The binding energy of the Helium nucleus from above would be:  $E = m c^2 \rightarrow E = (0.048 \times 10^{-27}) \times (3.0 \times 10^8)^2$   
 $E = 4.32 \times 10^{-12} \text{ J}$

The Joule is too big a unit to use at the atomic scale. We will use the electron Volt (see AS Unit 1)

$$1u = 1.5 \times 10^{-10} \text{ J} \quad \text{and} \quad 1\text{eV} = 1.60 \times 10^{-19} \text{ J} \quad \rightarrow \quad 1u = 931.3 \text{ MeV}$$

We can now calculate the binding energy of the Helium nucleus to be:  $E = 27 \text{ MeV}$  (27 million eV)

## Binding Energy Graph

The binding energy is the energy required to separate a nucleus into its constituent nucleons. The binding energy per nucleon gives us the energy required to remove one proton or neutron from the nucleus. The graph of binding energy per nucleon against nucleon number looks like this.

There is an increase in the energy required to remove one nucleon up until the peak of 8.8 MeV at Iron 56. The line then gently decreases. This means Iron is the most stable nucleus because it requires the largest amount of energy to remove one nucleon. This will also mean that there is the greatest mass defect

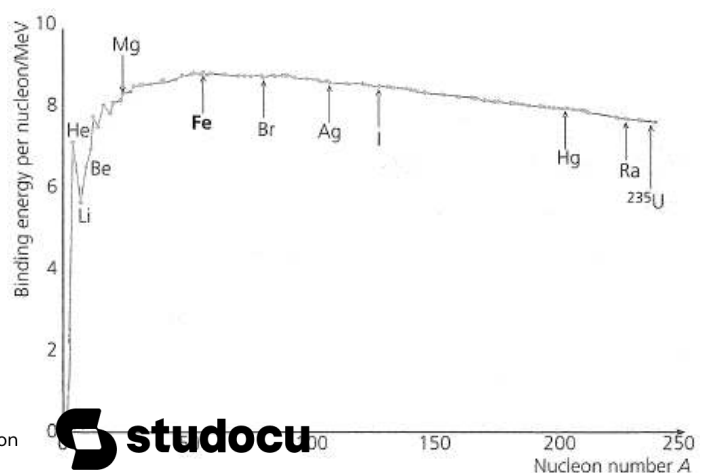

Unit 6	Mr Shepherd	
	<h1>Fission and Fusion</h1>	
Learning Outcomes	To know what occurs in nuclear fission and nuclear fusion processes	
	To know what a chain reaction is, how it occurs and what critical mass is	
	To be able to state and explain whether fission or fusion will occur	

## Nuclear Fission (Also see GCSE Physics 2)

*Fission occurs when a nucleus splits into two smaller nuclei*

We make fission happen by firing slow moving neutrons at Uranium 235, Plutonium 239 or Thorium 232 nuclei. We call this *induced fission*. In this processes the nucleus absorbs a neutron then splits to form two lighter nuclei, releases energy and any neutrons left over, usually 2 or 3.

Here is a possible equation for the fission of Uranium 235:

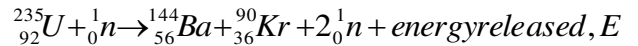

### Chain Reaction

In the above reaction two free neutrons were released, these can also be absorbed by two heavy nuclei and cause a fission process. These nuclei would release more neutrons which could cause further fissions and so on.

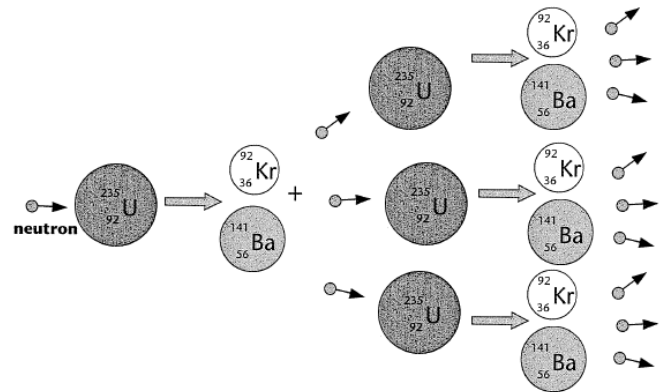

### Critical Mass

For a chain reaction to happen the mass of the fissionable material must be greater than a certain minimum value. This minimum value is known as the *critical mass* and is when the surface area to mass ratio is too small.

If mass < critical mass: more neutrons are escaping than are produced.

If mass = critical mass: number of neutrons escaping = number of neutrons produced.

If mass > critical mass: more neutrons are produced than are escaping.

Stops

Steady

Meltdown

## Nuclear Fusion (Also see GCSE Physics 2)

*Fusion occurs when two nuclei join to form a bigger nucleus*

The two nuclei must have very high energies to be moving fast enough to overcome the electrostatic repulsion of the protons then, when close enough, the strong nuclear force will pull the two nuclei together.

Here is an example of the fusing of two hydrogen isotopes:

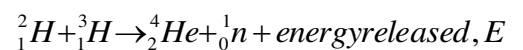

### Which Will Happen?

Looking at the graph we can see the Iron 56 has the highest binding energy per nucleon, the most energy required to remove one proton or neutron from the nucleus. This makes it the most stable.

*Nuclei lighter than Iron will undergo fusion.*

Protons and neutrons feel the attraction of the strong nuclear force but only protons feel the repulsion of the electrostatic force. For light nuclei, adding an extra proton increases the strong nuclear force to pull the nucleon together. This is because at this range the s.n.f. force is stronger than the other three fundamental forces.

The nucleons move closer together → potential energy is lost → energy is given out

*Nuclei heavier than Iron will undergo fission.*

Beyond Iron, each proton that is added to the nuclei adds to the electrostatic repulsion. The bigger the nucleus become the less the outer protons feel the strong nuclear force from the other side. We can see the binding energy per nucleon decrease for heavier nuclei.

A big nucleus will break into two smaller nuclei, each being stronger bonded together due to the smaller size.

The nucleons move closer together → potential energy is lost → energy is given out.

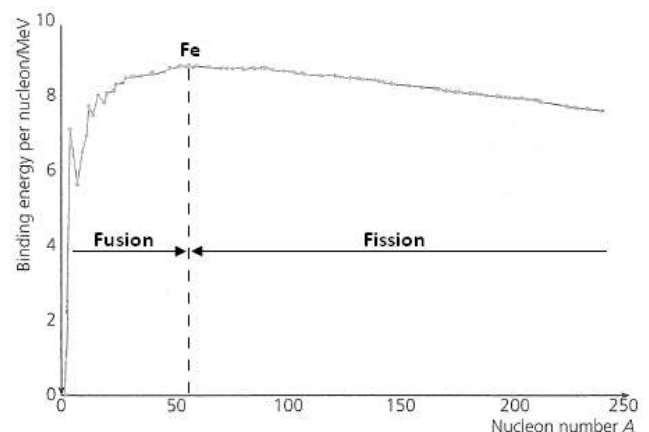

Unit 6	Mr Shepherd <h1>Nuclear Reactors</h1>	
Learning Outcomes	To be able to explain how a nuclear reactor produces electricity	
	To be able to explain the roles of the fuel rods, moderator, coolant and control rods	
	To be able to give examples of the materials use for each of the above	

## Making Electricity

This is a typical nuclear fission reactor. A nuclear power station is similar to a power station powered by the combustion of fossil fuels or biomass. In such a station the fuel is burnt in a boiler, the heat this produces it uses to heat water into steam in the pipes that cover the roof and walls of the boiler. This steam is used to turn a turbine which is connected to a generator that produces electricity (see GCSE Physics 3 and A2 Unit 4). Steam enters the cooling towers where it is condensed into water to be used again.

In a nuclear fission reactor the heat is produced in a different way.

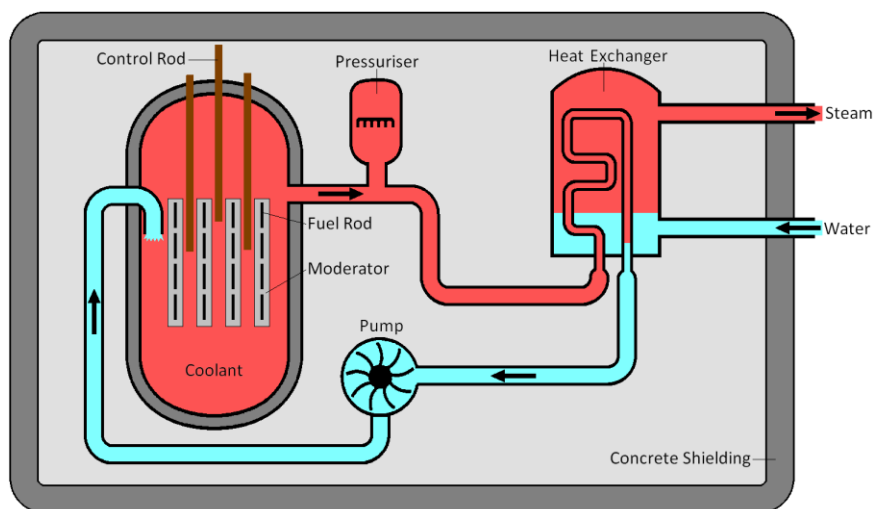

## Components of a Nuclear Reactor

### Fuel Rods

This is where nuclear fission reactions happen. They are made of Uranium and there are hundreds of them spread out in a grid like pattern.

Natural Uranium is a mixture of different isotopes. The most common are  $U^{238}$  which accounts for 99.28% and  $U^{235}$  which accounts for only 0.72% of it.  $U^{238}$  will only undergo fission when exposed to very high-energy neutrons whilst  $U^{235}$  will undergo fission much more easily. The Uranium that is used in fuel rods has a higher percentage of  $U^{235}$  and is said to be **enriched**. This is so more fission reactions may take place.

### Moderator

**Role:** The neutrons that are given out from nuclear fission are travelling too fast to cause another fission process. They are released at  $1 \times 10^7$  m/s and must be slowed to  $2 \times 10^3$  m/s, losing 99.99975% of their kinetic energy. The neutrons collide with the atoms of the moderator which turns the kinetic energy into heat. Neutrons that are travelling slow enough to cause a fission process are called **thermal neutrons**, this is because they have the same amount of kinetic energy as the atoms of the moderator (about 0.025 eV at 20°C).

**Factors affecting the choice of materials:** Must have a low mass number to absorb more kinetic energy with each collision and a low tendency to absorb neutrons so it doesn't hinder the chain reaction.

**Typical materials:** graphite and water.

### Coolant

**Role:** Heat is carried from the moderator to the heat exchanger by the coolant. The pressuriser and the pump move the hot coolant to the heat exchanger, here hot coolant touches pipes carrying cold water. Heat flows from hot coolant to cold water turning the water into steam and cooling the coolant. The steam then leaves the reactor (and will turn a turbine) as the coolant return to the reactor.

**Factors affecting the choice of materials:** Must be able to carry large amounts of heat (L11 The Specifics), must be gas or liquid, non-corrosive, non-flammable and a poor neutron absorber (less likely to become radioactive).

**Typical materials:** carbon dioxide and water.

### Control rods

**Role:** For the reactor to transfer energy at a constant rate each nuclear fission reaction must lead to one more fission reaction. Since each reaction gives out two or more we must remove some of the extra neutrons. The control rods absorb neutrons, reducing the amount of nuclear fission processes occurring and making the power output constant. They can be lowered further into the fuel rods to absorb more neutrons and further reduce the amount of fission occurring. Some neutrons leave the reactor without interacting, some travel too fast while others are absorbed by  $U^{238}$  nuclei. If we need more neutrons we can raise the control rods.

**Factors affecting the choice of materials:** Ability to absorb neutrons and a high melting point.

**Typical materials:** boron and cadmium



Unit 6	Mr Shepherd	
	<h1>Nuclear Safety Aspects</h1>	
Learning Outcomes	To be able to list and explain the safety features of a nuclear reactor	
	To be able to explain how an emergency shut-down happens in a nuclear reactor	
	To be able to state and explain the methods of nuclear waste disposal	

## ***Nuclear Reactor Safety***

There are many safety features and controls in place designed to minimise the risk of harm to humans and the surrounding environment.

### ***Fuel Used***

Using solids rather than liquids avoids the danger of leaks or spillages. They are inserted and removed from the reactor by remote controlled handling devices.

### ***Shielding***

The reactor core (containing the fuel, moderator and control rods) is made from steel and designed to withstand high temperatures and pressures.

The core itself is inside a thick, leak proof concrete box which absorbs escaping neutrons and gamma radiation. Around the concrete box is a safety area, not to be entered by humans.

### ***Emergency Shut-down***

There are several systems in place to make it impossible for a nuclear disaster to take place:

If the reactor needs stopping immediately the control rods are inserted fully into the core, they absorb any neutrons present and stop any further reactions from happening.

Some reactors have a secondary set of control rods held up by an electromagnet, so if a power cut happens the control rods fall into the core.

If there is a loss of coolant and the temperature of the core rises beyond the safe working limits an emergency cooling system floods the core (with nitrogen gas or water) to cool it and absorb any spare neutrons.

## ***Nuclear Waste Disposal***

There are three levels of waste, each is produced, handled and disposed of in different ways:

### ***High-level Radioactive Waste***

**What it is?** Spent fuel rods from the reactor and unwanted, highly radioactive material separated from the spent fuel rods.

**How do we get rid?** The spent fuel rods are taken from the reactor and stored in cooling ponds with in the power station to allow most of the short-term radioactivity to die away. It is then transported to a processing plant. Here it is encased in steel containers and kept under water.

The cladding is eventually removed and the fuel rods are separated into unused uranium and plutonium and highly radioactive waste.

The uranium and plutonium is kept in sealed container for possible future use.

The waste is converted into powder, fused into glass blocks, sealed in air-cooled containers for around 50 years before being stored deep underground in a stable rock formation.

**Time scale?** Up to a year in the cooling ponds. Radioactive waste can remain at dangerous levels for thousands of years.

### ***Intermediate-level Radioactive Waste***

**What it is?** Fuel element cladding, sludge from treatment processes, contaminated equipment, hospital radioisotopes and containers of radioactive materials.

**How do we get rid?** Sealed in steel drums that are encased in concrete and stored in buildings with reinforced concrete. Also stored deep underground in a suitable location that has a stable rock formation and low water flow.

**Time scale?** Thousands of years.

### ***Low-level Radioactive Waste***

**What is it?** Worn-out laboratory equipment, used protective clothing, wrapping material and cooling pond water.

**How do we get rid?** Sealed in metal drums and buried deep underground in a supervised repository. Treated cooling pond water is released into the environment.

**Time scale?** A few months.