

Model File Name: ATP-015

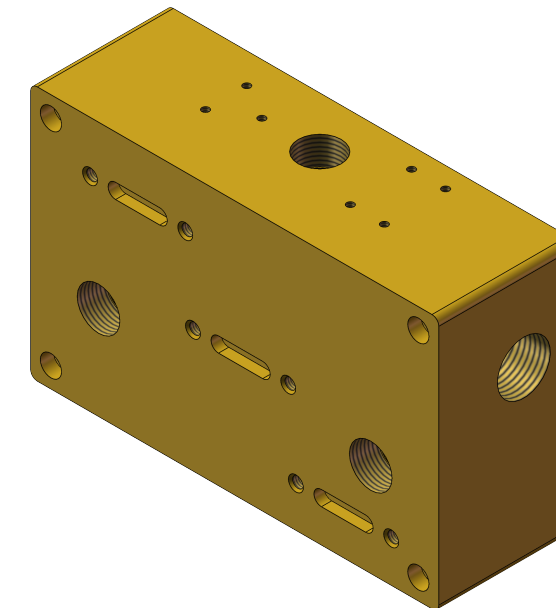
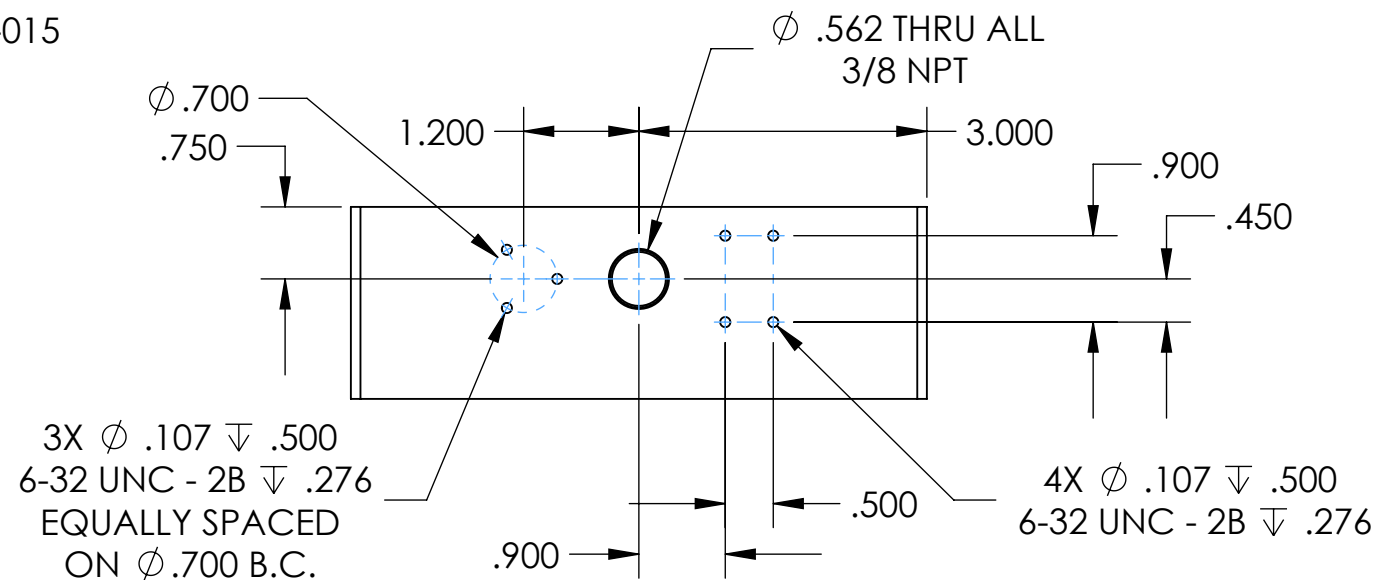

D

D

C

C

B

B

A

A

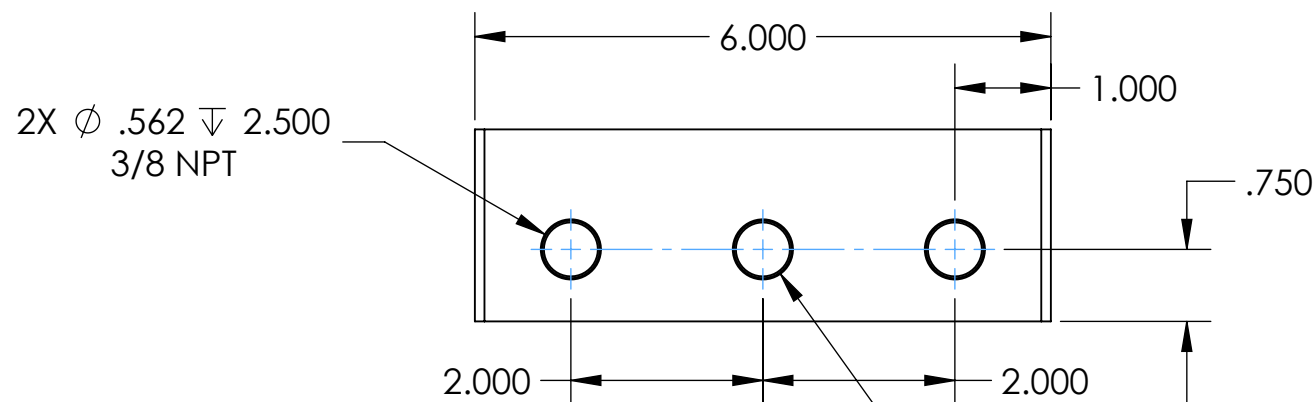
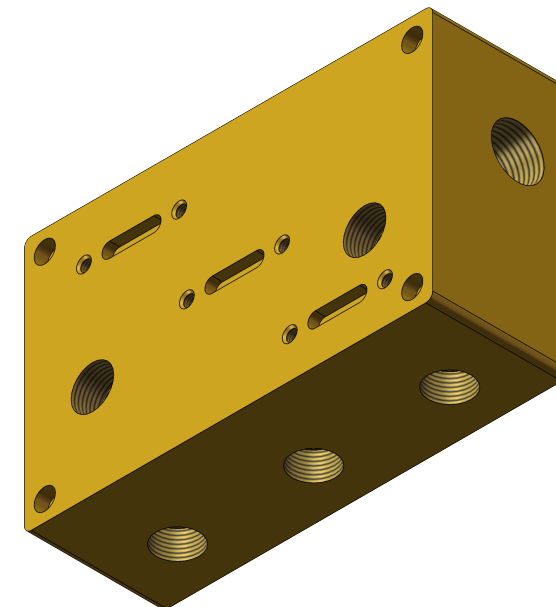
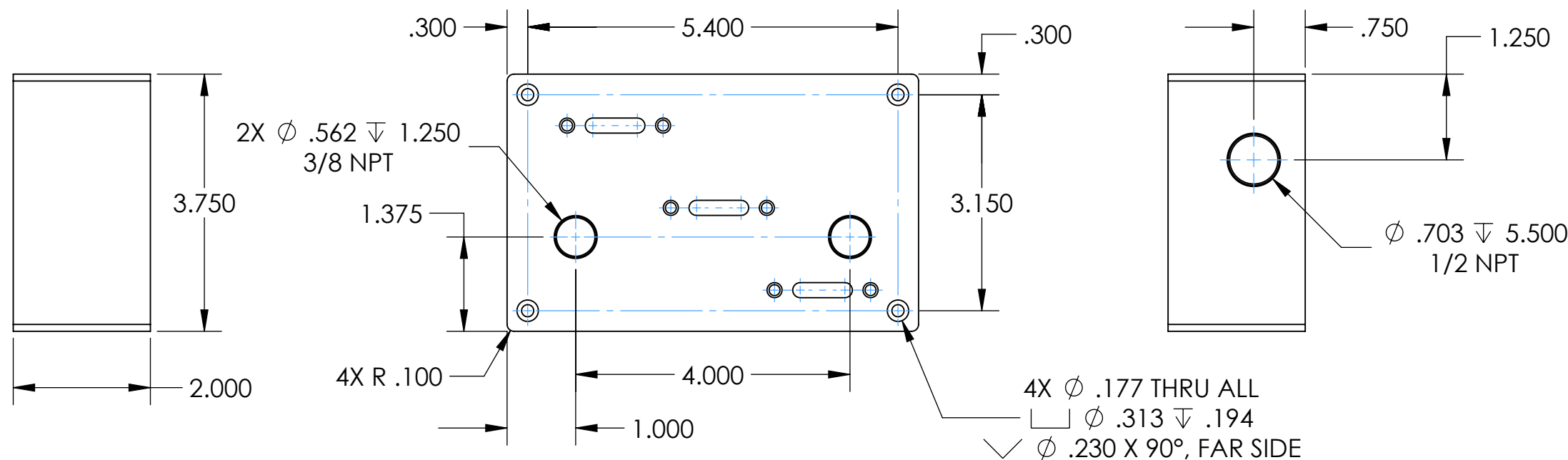

- NOTES:
1. DRAWING TO BE INTERPRETED IN ACCORDANCE WITH ASME Y14.5-2018
 2. MATERIAL: BRASS
 3. DENSITY: 8,500 kg/m³
 4. VOLUME: 39.878 CUBIC INCHES
 5. MASS: 12.246 LBS

DIMENSIONS IN INCHES

THIRD ANGLE PROJECTION



 Agile Academy agile-academy.tech	
DO NOT SCALE PRINT TOLERANCES UNLESS OTHERWISE SPECIFIED .XX ± .01 .XXX ± .005 ANGLE ± 1°	
MANIFOLD 01 SAMPLE PARTS	
DRAWN BY JEV	DRAWING NO. ATP-015
CHECKED BY JLM	SCALE: 1:2 DATE 1/9/2025 SHEET 1 OF 3
SIZE B	

Model File Name: ATP-015

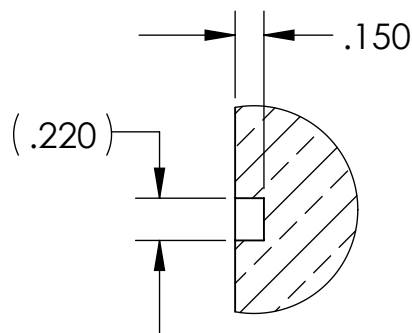
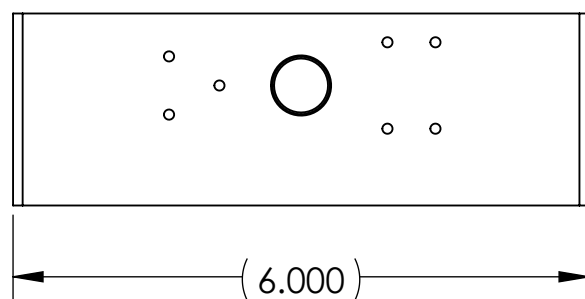

DETAIL C
SCALE 1 : 1
3 PLACES

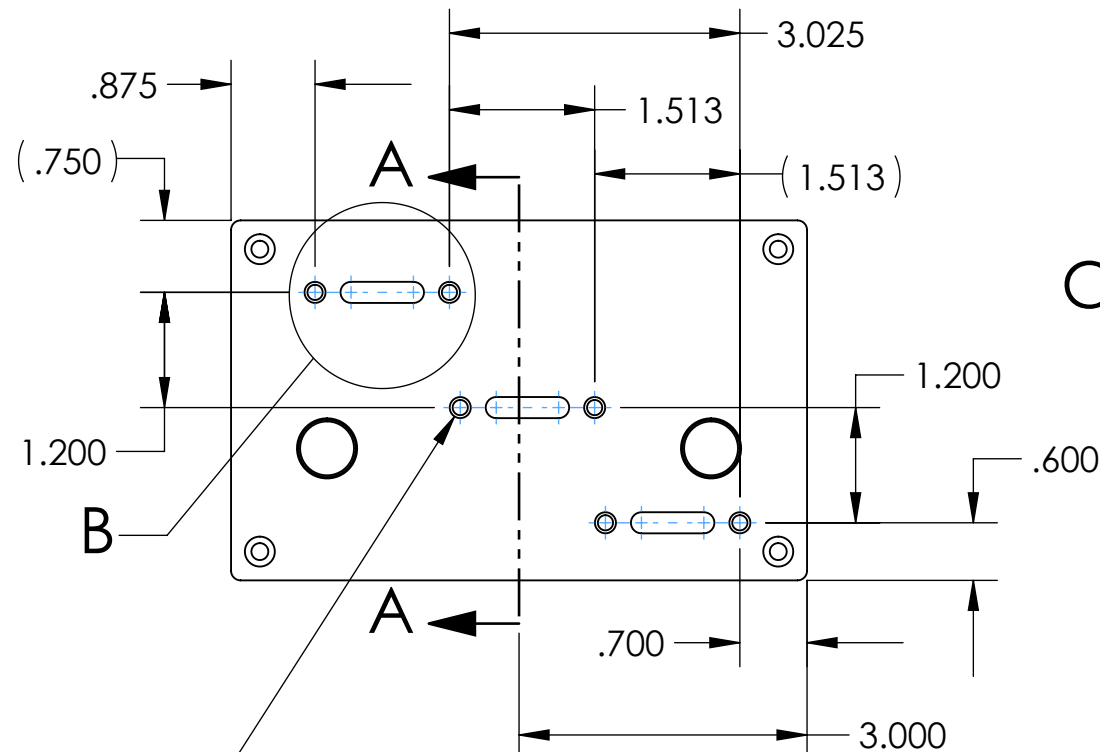
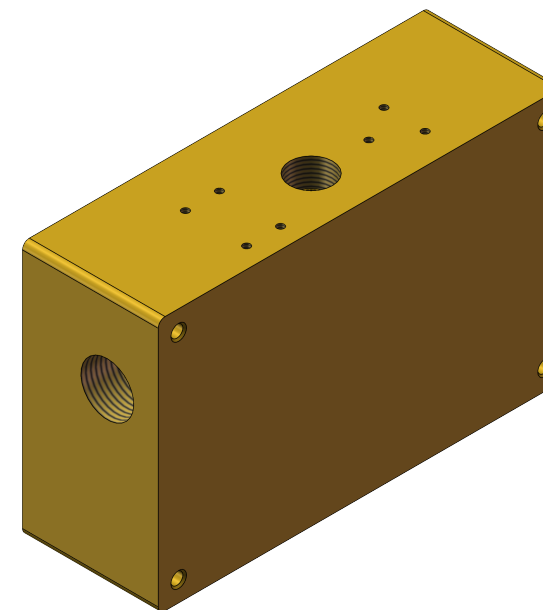

6X ϕ .159 ∇ .656
10-32 UNF - 2B ∇ .500
 \checkmark ϕ .220 X 90°, NEAR SIDE

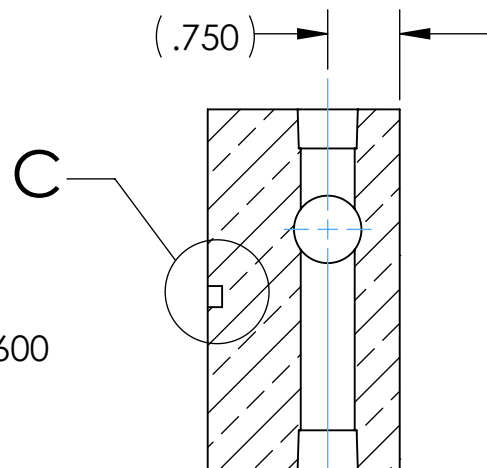

SECTION A-A

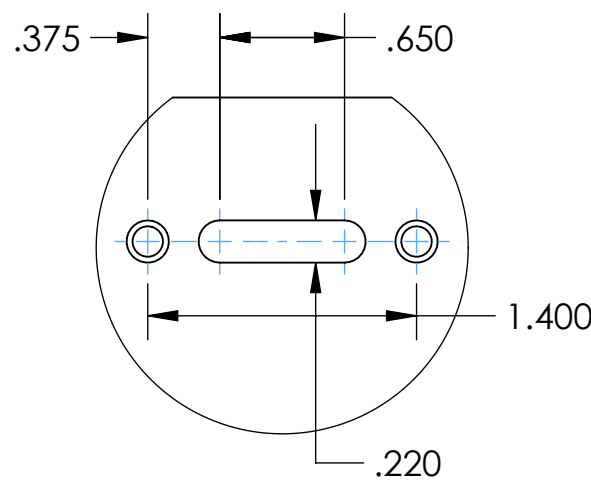
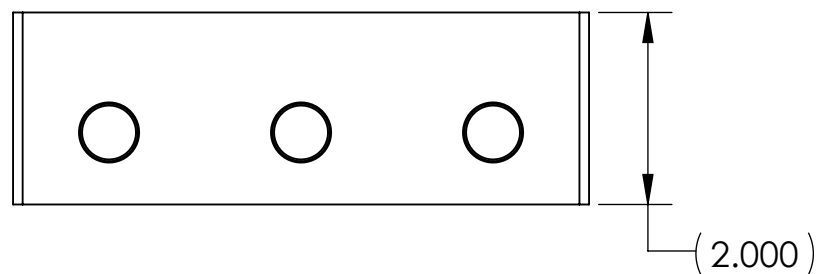
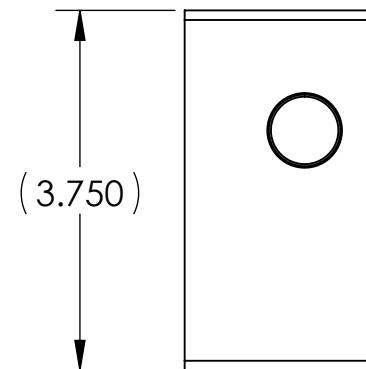

DETAIL B
SCALE 1 : 1
3 PLACES

DIMENSIONS IN INCHES

THIRD ANGLE PROJECTION



 Agile Academy agile-academy.tech	
DO NOT SCALE PRINT TOLERANCES UNLESS OTHERWISE SPECIFIED .XX \pm .01 .XXX \pm .005 ANGLE \pm 1° SIZE B	
MANIFOLD 01 SAMPLE PARTS	
DRAWN BY JEV	DRAWING NO. ATP-015
CHECKED BY JLM	SCALE: 1:2 DATE 1/9/2025 SHEET 2 OF 3

- NOTES:
1. DRAWING TO BE INTERPRETED IN ACCORDANCE WITH ASME Y14.5-2018
 2. MATERIAL: BRASS
 3. DENSITY: 8,500 kg/m³
 4. VOLUME: 39.878 CUBIC INCHES
 5. MASS: 12.246 LBS

Model File Name: ATP-015

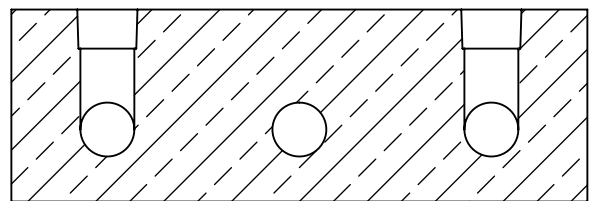
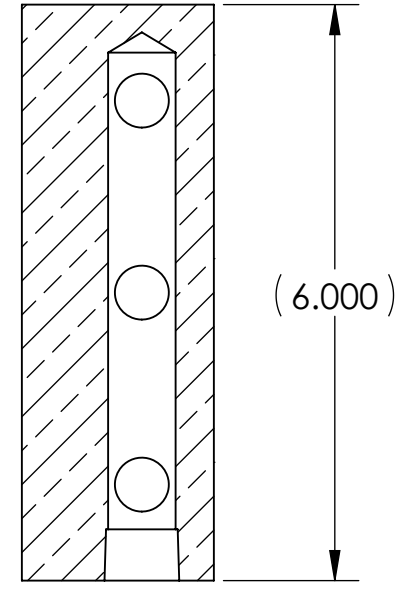
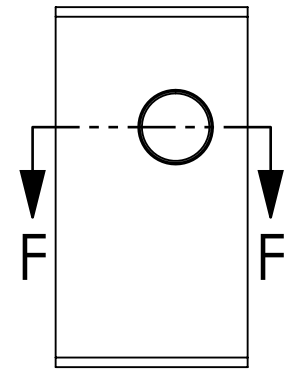
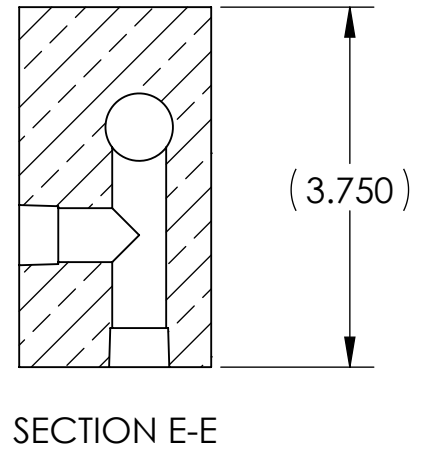
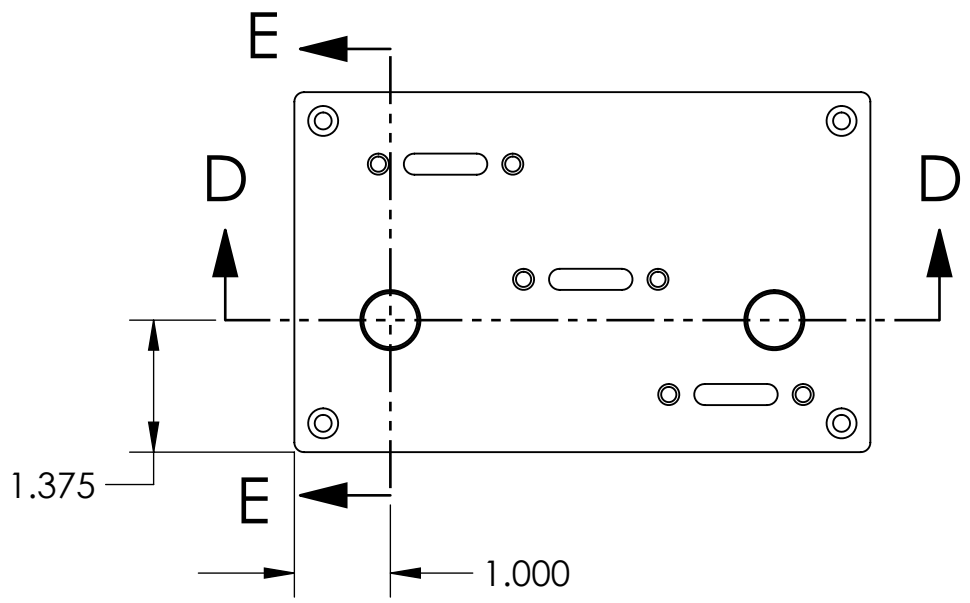

SECTION D-D

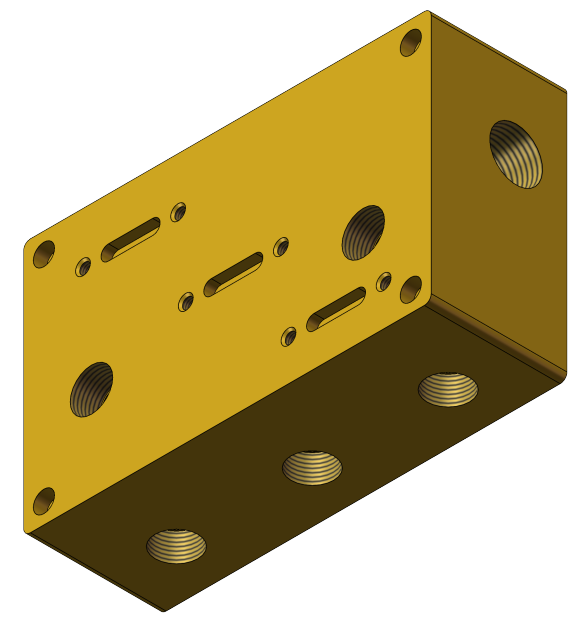
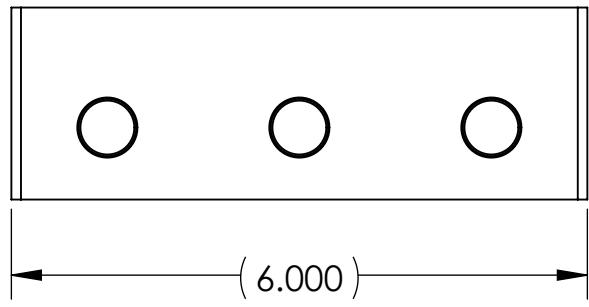

DIMENSIONS IN INCHES

THIRD ANGLE PROJECTION

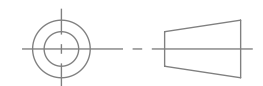

- NOTES:
1. DRAWING TO BE INTERPRETED IN ACCORDANCE WITH ASME Y14.5-2018
 2. MATERIAL: BRASS
 3. DENSITY: 8,500 kg/m³
 4. VOLUME: 39.878 CUBIC INCHES
 5. MASS: 12.246 LBS

 Agile Academy agile-academy.tech	
DO NOT SCALE PRINT TOLERANCES UNLESS OTHERWISE SPECIFIED .XX ± .01 .XXX ± .005 ANGLE ± 1°	
DRAWN BY JEV	DRAWING NO. ATP-015
CHECKED BY JLM	SCALE: 1:2 DATE 1/9/2025 SHEET 3 OF 3
SIZE B	